

3-POINT TRENCHERS 2 MODELS FOR PTO HYDROSTATIC TRACTORS

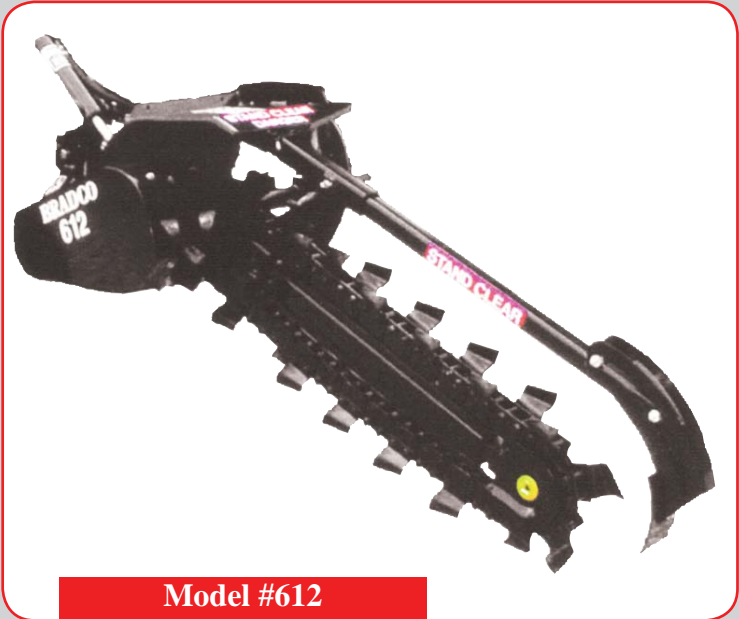

**Model #330
For Tractors 15 - 30 HP**



**Model #612
For Tractors 20 - 45 HP**



**Horizontal
Position**

Make your tractor more versatile with our 3-point hitch, PTO driven trenchers. The trenchers fit compact tractors with hydrostatic transmissions. These units will fit most trenching requirements with digging widths of 3 to 12 inches and depths of 30 to 60 inches depending on the model. Built with heavy duty components, these trenchers will stand up to the most difficult soil conditions.

Manufactured by:



PALADIN LIGHT CONSTRUCTION

FEATURES (MODEL 330):

- Cat. 1, 3-point mount for 15 - 30 PTO H.P. hydrostatic tractors with rear remote
- Maintenance free PTO shaft drive with automatic slip clutch for overload protection
- 14" Discharge auger
- 30" & 36" Digging depth available to fit most applications
- Digging widths of 3, 4 ½, 6 & 8 inches
- 38,000 lb. 1.654" Anti-back flex chain for tooth pattern versatility to support many soil types and conditions
- Compatible with model 615 chains
- ASAE S278.6 standard quick attach compatible
- Support stand is a standard feature

SPECIFICATIONS (MODEL 330):

3-POINT MOUNTING		Category 1	
A	Trench Depth w/auger at 65° digging angle	30"	36"
B	Chain Width	3"	3"
		4 ½"	4 ½"
		6"	6"
		8"	8"
C	Recommended Trenching Angle	65°	65°
D	Headshaft Height (auger touching ground)	8 ½"	8 ½"
E	Overall Length	73"	79"
F	Overall Width	38"	38"
G	Overall Height	29"	29"
H	Spoil Discharge Reach	21"	21"
L	Length - 3-pt. to Headshaft (center of gravity)	24'	24"
M	Transport Angle	48°	48°
HYDRAULIC SYSTEM			
	Operating Hydraulic Pressure (PSI)	2000 to 2500	
	Rear PTO RPM Rating	540 RPM	
	Rear PTO HP Rating	15 to 30 HP	

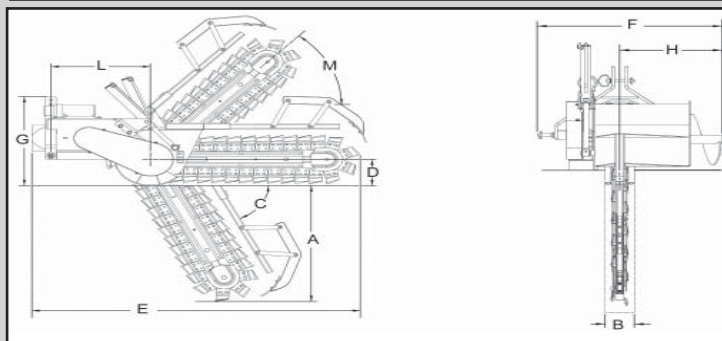

FEATURES (MODEL 612):

- Designed for Cat. 1, 20 - 45 HP hydrostatic transmission tractors with rear remote
- Digging depths from 30 to 60 inches deep
- Digging widths from 6 to 12 inches wide, depending on depth
- 4 Disc clutch incorporated into the PTO shaft to protect tractor and trencher
- Large 24" discharge auger places soil away from trench
- 50,000 Pound test - double standard - anti-back flex chain
- Teflon dirt shields protect sealed idler bearing for longer life
- Cup teeth-combo rock and frost chains available

SPECIFICATIONS (MODEL 612):

3-POINT MOUNTING		Category 1	
A	Trench Depth	30", 36", 48", 60"	
B	Trench Width	6", 8", 10", 12"	
C	Trenching Angle	65°	
	Auger Diameter	24"	
D	Overall Width	43"	
F	Headshaft Height (auger at grade)	12"	
G	3-Pt. Length to Headshaft	24"	
H	Spoil Discharge Reach	29"	
L	Transport Height	Varies	
	Center of Trencher to End of Auger	27"	
N	Trencher Length with 4' Boom	96"	
MAX. TRENCHING DEPTHS (based on trench width)			
	6" Wide	60" Deep	
	8" Wide	48" Deep	
	10" Wide	36" Deep	
	12" Wide	30" Deep	
* requires hydraulic power outlets at rear of tractor or valve kit required			

