



COMPLETE LINE OF
AGRICULTURAL, LANDSCAPE, &
CONSTRUCTION ATTACHMENTS
FOR OVER 60 YEARS

2025
PRODUCT CATALOG

14 **NEW** PRODUCTS

Increase Productivity



VINEYARD



ORCHARD



FARM

Reduce Operation Cost



RANCH



LANDSCAPE



CONSTRUCTION

ATTACHMENTS FOR TRACTORS-LOADERS-EXCAVATORS

2025 PRODUCT CATALOG

PRODUCT INDEXPAGE NO.

Aerators.....	2
Blades.....	3
Breakers, Hydraulic.....	4
Cultivators, Arena, Soil Conditioners.....	5 - 6
Cultivators, In-Row Vineyard.....	7, 8
Diggers, PTO.....	9
Diggers, Hydraulic.....	10
Discs.....	11 - 15
Dusters, 3-Point.....	16
Dusters, Row Crop, Trailer.....	17
Forks, Bale Spear.....	18 - 20
Harrows, Chain.....	21
Harrows, Rotary, Quick Hitch.....	22
Hedger/Toppers/Skirters.....	23 - 25
Implements, Stand On Track Loaders.....	26
Implements, Compact Tractor.....	27
Implements, Construction - Compaction Wheels, 4-in-1 Bucket, Sifting Bucket, 3-Point Trencher.....	28
Implements, Various: Ripper Bars, Mixer, 3-Pt. Roller, Pull Type Rollers, Tooth Bars, and Adjustable Thumb.....	29
Loaders, Implements & Hydr. Kits.....	30
Mowers/Shredders, Ditch Bank.....	31 - 36
Shredders, Hydr & Brush Processor... ..	37 - 42
Mowers, Rotary.....	43
Planters.....	44, 45
Rakes, Landscape, Ridgers.....	46
Rippers.....	47, 48
Scrapers, 3-Point, Top & Tilt Kits.....	49 - 51
Scrapers, Drag, Grading & Corral.....	52 - 54
Scrapers, Laser, Grader Blade.....	55 - 57
Skid Steer Attachments.....	58, 59
Sprayers, Boom.....	60 - 63
Sprayers, Air Blast.....	64
Sprayers, Venturi, 3-Point.....	65 - 70
Sprayers, Venturi, Trailer.....	71 - 74
Sprayers, Wrap-A-Round.....	75
Sprayers, Row Crop Air Boom.....	76
Spreaders, Spinner, Compost.....	77 - 79
Spreaders, Pendulum.....	80
Sweepers.....	81, 82
Tillers, Incorporators, Spaders.....	83 - 88
Top & Tilt Kits.....	49
Tree Sawhead.....	89
Trailers, Dump.....	90
Vineyard Implements: Vine Trimmers, Leaf Removers, Prepruners.....	91 - 98
Worksaver Implements: Grapple Buckets, Post Drivers, Concrete Mixers, Stump Grinders.....	99



This catalog presents a wide selection of equipment for farms, vineyards, orchards, landscapers, construction and municipalities. We supply 220 different implements in 725 various widths and capacities to fit customers exact requirements.

Gearmore provides quality implements, through servicing tractor dealers. It is Gearmore’s continuing goal to develop and provide the finest and most reliable equipment at affordable prices. Please use this catalog when considering your equipment requirements, then visit your local tractor dealer for more detailed product information and pricing.

Please visit our website (www.gearmore.com) to download the latest version of our catalog. We also have expanded literature pages to download. Plus, you can download a copy of parts/operation manuals for current as well as prior models of our implements.

For detailed literature, features, specifications, videos and spare parts manuals on all our products, please refer to our website www.gearmore.com.



LARGEST INVENTORY OF IMPLEMENTS ON THE WEST COAST - OUR FACILITY HAS OVER 2 ACRES OF WAREHOUSE OVER 93,000 SQ. FT. ON 5 ACRES OF LAND.

Specifications Subject To Change Without Notice

AERATORS

Advanced Aeration Systems

3-Point hitch and pull type turf aerators



Air and water move together in the soil

Aerated Soil

Reduced runoff

Increased microbial activity



Deeper growth

Increased fertilizer utilization



Shattertine®



Sportstine®

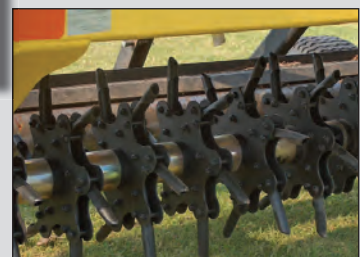

Coring Tine®

This is a fast, effective, low cost method to keep the soil surface open and minimize compaction without disrupting use of the turf area. As surface compaction is a continuous problem, caused by both use (foot traffic) and maintenance (mowing), venting aeration should be scheduled as often as possible to be effective. AerWay's complete line of **Turf Aerators** feature 3 different tine rotors to handle your exact requirements. The polyethylene built-in ballast tanks, when filled with water, obtain maximum tine penetration. Some of the popular options are: smoothing rear roller and tine spacings from 3 to 6 inches.

WIDTH	APPROX. H.P. W/BALLAST	3-POINT WEIGHT	3-POINT WT. W/BALLAST	PULL TYPE WEIGHT	PULL TYPE WT. W/BALLAST
45"	20 - 30	977 lbs.	1,627 lbs.	1,194 lbs.	1,844 lbs.
60"	25 - 40	1,143 lbs.	2,000 lbs.	1,437 lbs.	2,300 lbs.
75"	30 - 45	1,223 lbs.	2,263 lbs.	1,587 lbs.	2,627 lbs.
90"	40 - 65	1,398 lbs.	2,648 lbs.	1,753 lbs.	3,000 lbs.



Marketed by Gearmore, Inc.

"GB" Series

3-Point hitch - 5' to 10' widths

REAR BLADES

GB5 / GB6

The **GB5 & GB6 Rear Blades** for up to 30 H.P. tractors are the answer for compact tractor earth-moving requirements. They are the most versatile rear blades on the market today, as all of the standard features normally found only on large expensive rear blades, are standard on the Gearmore Rear Blade. Tilt, angle, offset, and reverse are easy to adjust so that any grading or ditching operation may be accomplished.

Cat. I
A.S.A.E.
Quick Hitch
Compatible

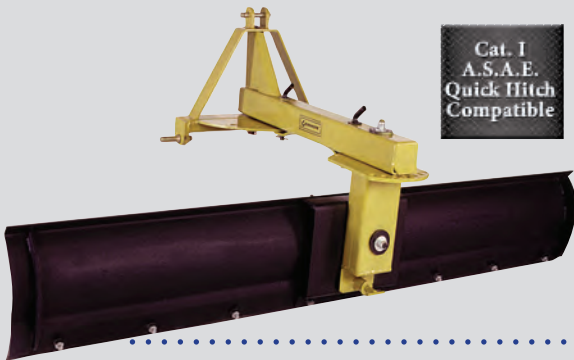
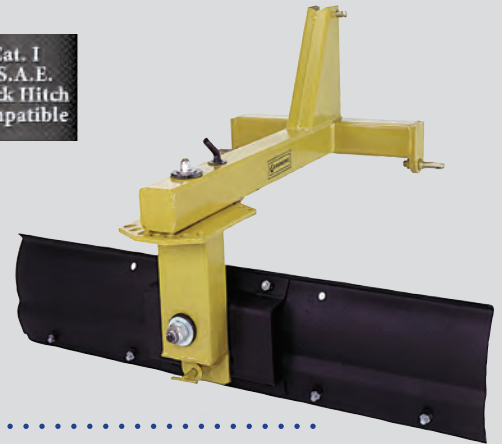

Cat. I
A.S.A.E.
Quick Hitch
Compatible

GB60 / GB70

The **GB60 & GB70 Rear Blades** are for any mid-size tractor up to 50 H.P.. These blades feature "Beam Swing" offset, which allows the heavy 4" x 4" beam to swing right or left to obtain maximum offset.

GB75 / GB85

The **All Manual or Hydraulic Adjustment GB75 & GB85 Rear Blades** are the answer to low cost, medium horsepower (up to 95 H.P.), earth moving requirements. Change ditching or grading angles by just pulling a pin.



CAT II
A. S. A. E.
QUICK
HITCH
COMPATIBLE

GB800 / GB900 / GB1000

The **Hydraulic GB800, GB900, & GB1000 Rear Blades** are for high horsepower (up to 125 H.P.) earth-moving requirements. These blades are available in full manual or any combination of manual/hydraulic functions. The heavy duty frame is rugged and reliable, assuring years of trouble-free use.



CAT II
A. S. A. E.
QUICK
HITCH
COMPATIBLE

SPECS:	3-PT.	ANGLE	TILT	OFFSET	WT.
GB5	Cat. I	45° R or L	14° to 25°	6" R or L	260#
GB6	Cat. I	45° R or L	14° to 25°	6" R or L	275#
GB60	Cat. I	45° R or L	14° to 25°	35" R or L	360#
GB70	Cat. I	45° R or L	14° to 25°	35" R or L	380#
GB75	Cat. II Clevis	50° R or L	20°	40" R or L	770#
GB85	Cat. II Clevis	50° R or L	20°	40" R or L	800#
GB800	Cat. II Clevis	30° R or L	14°	30" R or L	1,105#
GB900	Cat. II Clevis	30° R or L	14°	30" R or L	1,155#
GB1000	Cat. II Clevis	30° R or L	14°	30" R or L	1,215#

All GB series rear blades have ½" x 6" reversible cutting edges. The GB5/6 and GB60/70 have a 4" x 4" steel tube main beam with a 2" solid round king pin. The GB75/85 have a 5" x 5" steel tube main beam with a 3" solid round king pin, and the GB800/900/1000 have a 6" x 8" steel tube main beam with a 4" solid round king pin.

HYDRAULIC BREAKERS

Low cost - high production



Chisel Cone Blunt Moil



Breaker in action
skid steer mount

KEY POINTS:

- Only 2 moving parts
- Gas fired
- Auto shut-off
- Large tool diameter
- Shock isolation
- Noise reduction
- Durable side plates and housings

Paladin's New Strike Force Breakers provide exceptional performance and reliability for a variety of demolition tasks. From small excavation projects to the toughest demolition jobs, Paladin's Strike Force Breaker series has a smooth, powerful operation for maximum output energy and efficiency. Strike Force Small Mounted Breakers are ideal for mini excavators, skid steer loaders and compact backhoes for jobs that need a high breaking capacity.

FEATURES:

- 2 Popular sizes - 500 or 750 ft./lbs. of impact energy
- Piston and cylinder designed to transfer high shock waves
- Unique as breakers have only two moving parts
- Very easy to service and maintain
- 4 Different tool points are available - moil is standard options are - chisel, cone and blunt
- All breakers come standard with 2 moil tools and extra seal kit
- Mounting brackets are available for skid steer, mini excavators and compact backhoes

	SFB500	SFB750
Working weight	637	747
Impact energy class	500	750
Impact rate (blows/min.)	640-1470	620-1150
Operating pressure (PSI)	1,595-2,120	1,565-2,175
Relief pressure (PSI)	2,320-2,610	2,320-2,610
Oil flow (gal./min.)	10.0-21.9	11.9-21.9
Tool diameter (inches)	2.63	2.67
Pressure line size (inches)	3/4	3/4
Return line size (inches)	3/4	3/4
Carrier weight excavator (lbs.)	5,070-13,227	7,054-15,873

Built By:



MODEL #	DESCRIPTION	FT/LBS ENERGY	WT.
SFB500	Hydr. breaker <u>less</u> mtg. bracket	500	637#
SFB750	Hydr. breaker <u>less</u> mtg. bracket	750	747#

NOTE: Breakers are available up to 12,000 impact energy

One pass system

For re-conditioning arenas

CULTIVATORS



**SHOWN WITH
OPTIONAL SHANKS**

Cat. I
A.S.A.E.
Quick Hitch
Compatible



The **Arena-Vator III** is a highly versatile tool designed for a variety of arena surfaces. The new frame design will accept scarifier shanks that break up hard ground and can be equipped with a number of accessories to meet individual requirements. The AV-3 is designed to renovate and condition horse arenas and tracks in a single pass. It produces a firm, yet giving surface that provides the securest footing for your horses. Available in 4', 5', 6', 7', & 8' sizes. The standard unit is equipped with two rows of S-tine shanks with reversible points which loosen and cultivate the soil, an adjustable pipe leveler for leveling the soil, and a 12" diameter spiral rod rear roller to gauge the depth and pack the soil to provide a uniform finish.

FEATURES:

- Two rows of S-tines 1 ¼" x ¾" x 22" long with reversible and replaceable points
- Adjustable 4" diameter pipe leveling tube
- 12" Diameter spiral rod rear roller with turnbuckles for easy adjustment
- Cat. I, 3-point hitch on 4', 5', 6', and 7' models
- Cat. I & II, 3-point hitch on 8' model

OPTIONS:

- ~ Scarifier Shanks*
 - ~ Gauge Wheels
 - ~ Hitch to convert 3-point to pull type, 4' and 5' only
 - ~ Mesh rear roller in lieu of spiral rod roller
- *Not designed to go very deep*

OPTIONS



Pull Hitch



Mesh Roller



Gauge Wheel

MODEL #	DESCRIPTION	WT.
AV3-4	4' Arena-Vator III w/11 S-Tines	400#
AV3-5	5' Arena-Vator III w/13 S-Tines	480#
AV3-6	6' Arena-Vator III w/15 S-Tines	550#
AV3-7	7' Arena-Vator III w/17 S-Tines	660#
AV3-8	8' Arena-Vator III w/19 S-Tines	745#

CULTIVATORS

Soil Conditioners

Tills, levels, and finishes soil in a single pass

Cat. 1
A.S.A.E.
Quick Hitch
Compatible

GSC10 With 7" Sweeps



This Gearmore implement combines three different operations in order to obtain the maximum in soil conditioning. First the vibrating "S" tines break up the ground, then the spring loaded spike tooth bar levels and breaks up clods. The final operation is the spring loaded 12" diameter crumbler roller, which mulches and finishes leveling the soil. These **Soil Conditioners** are ideal for vineyards, orchards, nurseries, berries and general field work.

FEATURES:

- 20" High clearance "S" tines to penetrate and till up to 7" deep
- "S" tines are heavy duty 1/2" x 1 3/4" spring steel
- Heat-treated, 3/4" x 11" spikes on 6" centers
- Spring loaded, 12" diameter rolling crumbler with serrated bars angled to finish mulching the soil
- Tapered frame permits traveling through vegetation without damaging it
- Tapered rolling crumbler yokes, on all models, guide material around baskets
- Easy to adjust and operate
- Travel speeds up to 8 miles per hour
- Minimum investment cost and low maintenance
- Total soil mixing also causes faster water penetration to the root zone
- Completely mixes soil, does not fold it over or move it to the side like a disc
- Leaves ground perfectly level, as ridges are knocked down and holes are filled-in



1 3/8" Reversible Point or 7" Sweep

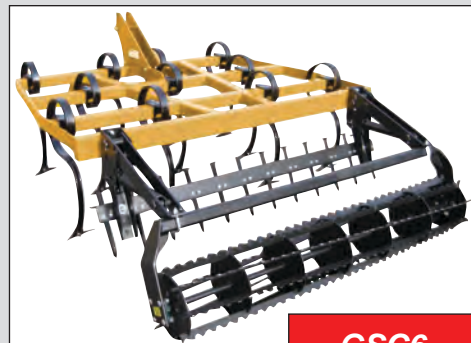

GSC6

MODEL #	WIDTH	"S" TINE BARS	NO. OF "S" TINES	NO. OF TEETH	ROLLING CRUMBLERS	WT.
GSC4	4'	2	7	8	1 - 4'	475#
GSC5	5'	3	9	10	1 - 5'	620#
GSC6	6'	3	11	12	1 - 6'	800#
GSC7	7'	3	13	14	1 - 7'	900#
GSC8	8'	3	15	16	1 - 8'	1,000#
GSC10	10'	3	19	20	2 - 5'	1,300#
GSC12	12'	3	23	24	2 - 6'	1,620#
GSC15	15'	3	29	30	3 - 5'	1,900#

Cultivators 4 to 7 feet are Cat. 1 - Cultivators 8 to 15 feet are Cat. 2 - Cultivators 10 to 15 feet come w/gauge wheels

Effective tool

For organic vineyard weed control

CULTIVATORS

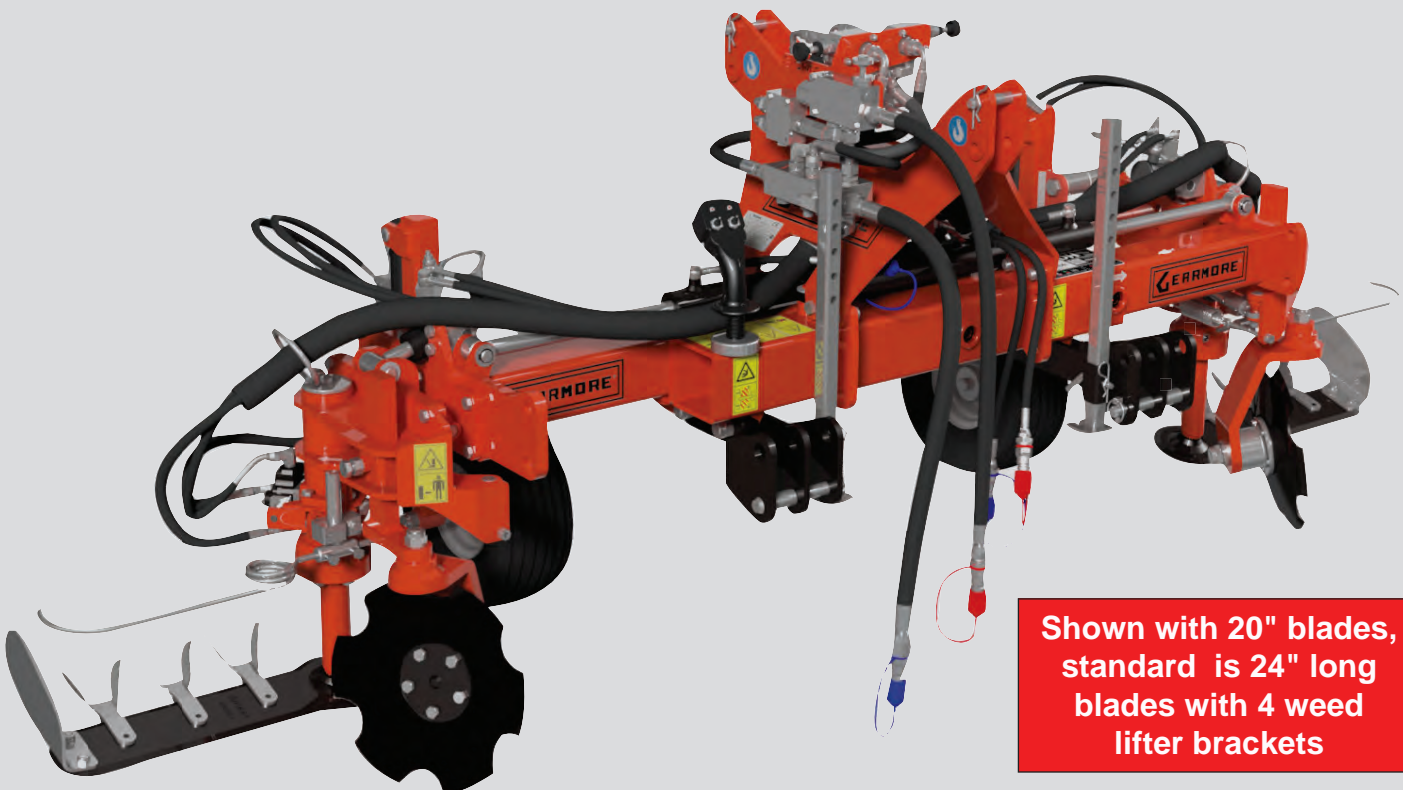

Our one and two row **In-Row Cultivators** are a very effective tool for under vine maintenance. First, the notched coulters cuts a furrow in front of the blade shaft to penetrate the soil for the cutting blades. The in-row blades undercuts weeds, while at the same time loosens and turns back the soil. The sensor rod hydraulically retracts the cutting blades around the base of the vines without damaging them. Blades have an override system to retract to avoid obstruction. The blades are excellent for working hard soils at speeds up to 5 miles per hour depending on field conditions.

FEATURES:

- Dual Cat. I and II ASAE 3-point quick hitches for mounting front or rear on tractors
- Heavy double square tubing frame with telescoping inner tubing
- Hydraulic cylinders for variable spread widths
- Blades are 24" (620 mm) long and reversible to double the life
- Adjustable screw jack dual gauge wheels with tires
- Electro hydraulic joystick
- Joystick is mounted with magnetic base for easy positioning from cultivator to tractor
- Adjustable notched coulter blades, 13 ¾" (350 mm) diameter for opening the soil for the blades
- The gauge wheels extend with the blade assembly for better depth control and stability
- Cultivators come complete with hydraulic hoses and JIC fittings
- Tractor minimum hydraulic requirement - 6.6 G.P.M.
- For tractors 50 to 90 horsepower
- Available in one or two row

NOTE: Some tractor hydraulic systems may require a hose for return to sump (zero back pressure)

* Dimensions based on 24" blades - 14" and 20" blades are also available allowing for narrow rows

MODEL #	NO. OF BLADES	FOR ROW WIDTHS	MIN. OVERALL WIDTHS	MAX. OVERALL WIDTHS	WT.
DH1 1000	One	6' to 8'	5' 8"	7' 4"	625#
DH2 1000	Two	8' to 10'	* 7' 11"	11'	880#
DH2 1400	Two	9' to 12'	* 9'	12' 4"	930#

CULTIVATORS, IN-ROW

For Vineyard rows 5 to 12 feet

NEW

NARROW ONE ROW

We offer 3 unique *In-Row Cultivators* for vineyard rows from 5 to 12 feet. Tools are available for tilling, flail mowing, string weeding and cutting blade with coulter. Many capacity options for year around maintenance. All tools are hydraulically retractable. All models are 3-point hitch, PTO driven with self-contained hydraulic system and cooling radiators.



Rotary Hoe - 16"
Retractable



Flail Mower - 20"
Retractable

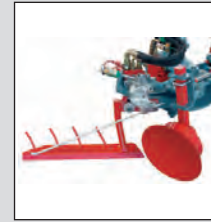

In-Row Blade - 24"
Retractable



String Mower - 24"
Retractable

FEATURES:

- Cat. I and II, 3-pt. hitch, PTO driven
- Hydraulic reservoir built into A frame
- Hydraulic sensor rod automatic retraction system
- Hydraulic tilt system for all tools
- All tools are optional

MODEL #	DESCRIPTION	ROW WIDTHS	WT.
M1TR5115	One Row Narrow Cultivator	5' to 7'	880#

ONE ROW CULTIVATORS

FEATURES:

- Cat. I and II, 3-pt. hitch, PTO driven
- Hydraulic sliding tube to adjust for different row widths
- Hydraulic blade trip retraction system
- The blade is equipped with hydraulic tilt

MODEL #	DESCRIPTION	ROW WIDTHS	WT.
M1P01016J	In-Row Cultivator, less tools	6' to 12'	800#

TWO ROW CULTIVATORS

FEATURES:

- Cat. II, 3-point hitch, PTO driven
- Hydraulic sliding tube to adjust for different row widths
- Sensor rod for automatic implement retraction
- Electric control box for operating hydraulic functions and overrides to avoid obstructions
- All required hoses are included

MODEL #	DESCRIPTION	ROW WIDTHS	WT.
M1PN1015J	2 Row In-Row Cultivator, less tools	8' to 11'	2,000#

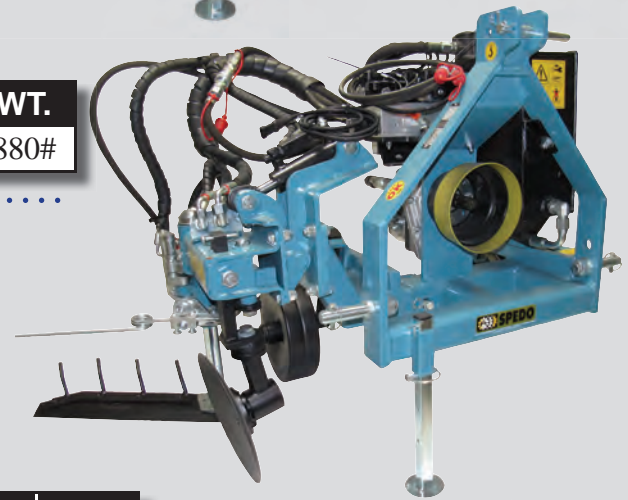

Built By:



3-Point Post Hole Diggers

4 models to match your horsepower

DIGGERS

**MODEL 300 FOR
SUB-COMPACT TRACTORS**



Shown with optional parking stand

**MODEL 720
HEAVY DUTY DIGGER**



**MODEL 500
STANDARD DUTY DIGGER**



**MODEL 925
INDUSTRIAL DIGGER**



DIG DEEPER, FASTER & SMARTER

The *Worksaver Post Hole Diggers* are engineered to allow the operator to dig deeper, faster and smarter. Worksaver's line of PTO powered diggers offer time saving convenience with outstanding reliability. Shear bolt protected driveline is coupled to a rugged gearbox featuring tapered roller bearings and spring loaded seals for extended service life. Large 2" output shaft has two bolt auger connection for reliable power transfer. All job matched augers utilize fishtail center points with double flighting on the first.

MODEL #	HORSEPOWER	CAT.	MAX. AUGER DIAMETER	AUGER LENGTH	WT.
300	Under 25 H.P.	I	12"	30"	149#
500	Under 35 H.P.	I	12"	42"	160#
720	25 - 65 H.P.	I	24"	42"	206#
925	40 - 95 H.P.	I	30"	42"	220#
Optional down force kit available					

FEATURES:

- 3-pt. hitch mounted
- 2" Output shaft
- Replaceable fishtail auger point
- Rugged 540 R.P.M. gearbox
- Shear pin drive
- 3 Boom positions
- Standard duty single flight and heavy duty double flight augers
- Optional parking stand

Built By:



DIGGERS

Hydraulic
7 sizes to match your GPM

The "X" Series Digger is the most trouble free hydraulic digger on the market today. These diggers feature an "in-line" sealed planetary gear reduction drive design. This clean, effective system ensures long, trouble free usage. All "X" Series models feature reverse rotation for quick backout when obstructions are encountered. The system's hydraulic relief valve protects the digger from damage when an auger hits large immovable objects.

FEATURES:

- 7 Models to match tractor G.P.M.'s from 5 to 40
- All units feature planetary gear reduction, except D450
- High torque motors ensure digging through the toughest of conditions
- Adapter plate mounting on most popular skid steers, backhoes, loaders, etc.
- 3 Models of augers designed to match your soil conditions

MODEL #	D450	X975	X1475	X1975	X2475	X4575	X5075
Min. Hyd. Flow GPM:	5	6	10	15	20	22	28
Max. Hyd. Flow GPM:	10	15	25	30	35	36	40
Max. Auger Diameter:	12"	24"	30"	36"	36"	48"	48"
Output Shaft Options:	2" Rd.	2" Hex	2" Hex	2" Hex	2" Hex	2" Hex	2" Hex

Medium duty, heavy duty and rock augers are available
Auger extensions available in 2" hex in lengths of 24", 48", & 72"

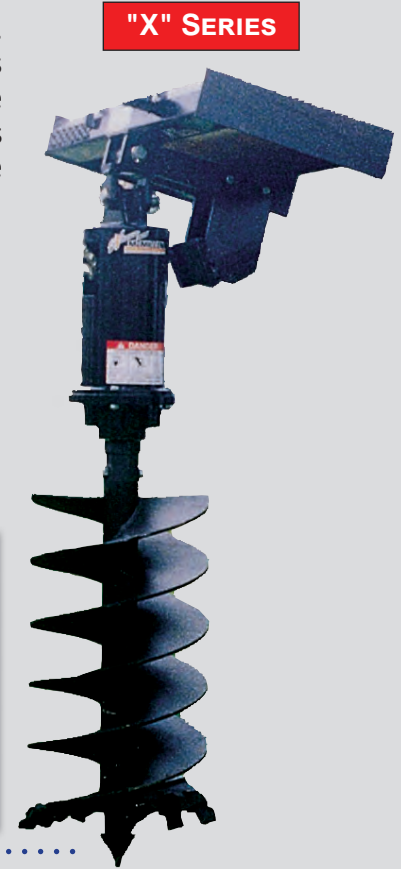

ROCK AUGERS - "HDR" STYLE AUGERS

For solid, frozen ground and compacted soils

"HDR" Auger	Dia.	Tooth Qty.
	6"	6
	9"	8
	12"	12
	18"	18
	24"	20
STD. FEATURES		
<ul style="list-style-type: none"> • Bullet style teeth & fabricated boring head • HD Single flight - 3/4" thick bottom flight • 2" Hex collar ONLY • 4' length 		

Built By:



AUGERS - HIGH QUALITY CONSTRUCTION

TRIMAX HEAVY DUTY - "HDC" STYLE AUGERS			STANDARD FEATURES
"HDC" Auger	Dia.	Tooth Qty.	
	6"	2	• HD Cast steel boring head
	9"	4	• Hardened drive-in teeth & chisel
	12"	4	• Hardened fishtail point
	15"	6	• HD double fighting
	18"	6	• Collars - 2" hex
	24"	8	• 4' length
	30"	10	
	48"	18	

MEDIUM DUTY - "HDF" STYLE AUGERS			STANDARD FEATURES
"HDF" Auger	Dia.	Tooth Qty.	
	6"	2	• Fabricated boring head
	9"	3	• Hardened bolt-on teeth
	12"	4	• Hardened fishtail point
			• HD dbl fighting
			• Collars - 2" round
			• 4' Length



FEATURES:

- Cat. I, 3-point ASAE quick hitch
- Frame and gang beams - 3" x 3" heavy tubing
- 18" Notched front and plain rear blades on 7 1/2" spacing
- Axles are 1" square high carbon steel
- Axle are triple sealed, with self-aligning ball bearings
- Gangs adjustable with 7°, 14°, and 21° settings
- Bearing hangers - 3/8" plate reinforced
- Handles for easy gang adjustment

MODEL #	CUT. WIDTH	H.P. RATING	BLADE DIA.	NO. OF BLADES	WT.
DH30-60C	60"	35 H.P. Max.	18"	16	735#
DH30-72C	72"	45 H.P. Max.	18"	20	815#
DH30-84C	84"	55 H.P. Max.	18"	24	885#

DISCS, TANDEM - "T" SERIES

FEATURES:

- Cat. I & II, 3-pt. hitch, ASAE quick hitch
- 3/16" x 22" notched front and plain rear blades
- Front & rear gangs adjustable to 7°, 14° or 21° settings
- 1 1/8" high carbon square axles
- 7 1/2" long cast spool spacers

MODEL #	CUT WIDTH	BLADE DIA.	NO. OF BLADES	WT.
T1622	5' - 6"	22"	16	1,100#
T2022	6' - 6"	22"	20	1,230#
T2422	7' - 6"	22"	24	1,345#
T2822	8' - 6"	22"	28	1,475#

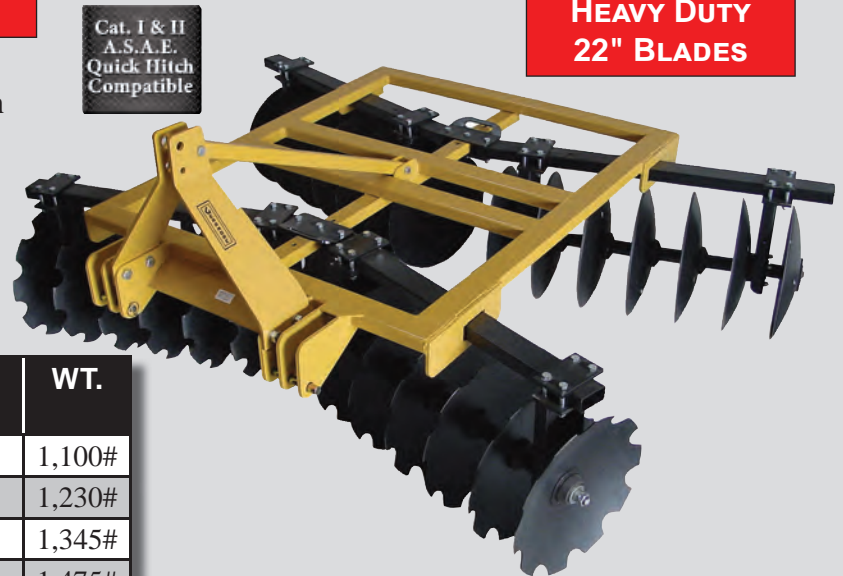

DISCS, OFFSET - "GO" SERIES



MODEL #	CUTTING WIDTH	NO. OF BLADES	WT.
GO24-69	6' - 9"	18	1,300#
GO24-76	7' - 6"	20	1,405#
GO24-83	8' - 3"	22	1,560#

FEATURES:

- Cat. II, 3-point quick hitch
- Heavy duty frame
- 24" Notched front and plain rear blades
- 9" Blade spacing
- 1 1/2" Square gang axles
- Double sealed flange mounted bearings
- Adjustable rear gang
- Steel spacer spools

Built By: **BWI**mplement

DISCS, TANDEM

"GV" & "GRT" Series
Heavy built for years of trouble free usage

DISCS, TANDEM - "GV" NARROW ROW SERIES

Narrow row crops like grapes, berries, pole tomatoes, etc., also require heavy duty tillage tools. Our **Narrow Row Tandem Disc** fits those requirements. This disc is excellent for knocking down weeds, leveling and mixing in residue. The 22" diameter notched front blades aid in cutting through hard soils, while the rear plain blades give a smooth finish. Flange mounted, double sealed, shielded bearings. A number of options are available, such as: dirt shield fenders, extension blades, bearing guards and special low position 3-point hitch.



MODEL #	ROW WIDTH	NO. OF BLADES	FRAME WIDTH	CUTTING WIDTH	WT.
GV-5R	5' (60")	8	48"	32" to 44"	1,200#
GV-6R	6' (72")	12	57"	50" to 62"	1,420#
GV-8R	8' (96")	16	75"	68" to 80"	1,745#

DISCS, TANDEM - "GRT" REVERSIBLE SERIES

Our heavier duty series of **Reversible Vineyard Discs** were designed for maximum strength and durability. The frame was built with heavy wall tubing for additional weight in tough soil conditions. The disc has 24" diameter plain blades front and rear. The 3-point hitch is Cat. II quick hitch, trunnion mounted bearings and 1" x 3" center shank. The reversible hitch can easily be remounted on the opposite end of the disc when required.



MODEL #	CUTTING WIDTH	NO. OF BLADES	WT.
GRT24P-HD-16	5' 8" to 7'	16	2,160#
GRT24P-HD-18	7' 2" to 8' 6"	18	2,260#
GRT24P-HD-20	7' 2" to 8' 6"	20	2,490#

Built By:

BWImplement



FEATURES:

- Frame:** 4" x 4" x 1/4"
Structural tubing
- Gang Frame:** Fully adjustable front to rear
- Hitch:** Self leveling, spring cushioned with hand crank
- Bearings & Axles:** 1 1/2" Square axles w/trunnion mount double lip sealed greaseable bearings with wear shield
- Blades:** 24" x 4.5 mm smooth blades
- Spools:** 9" Steel spacer spools & cast iron half spools
- Hydraulics:** 3 1/2" x 8" Cylinder
- Shank:** 1" x 3" Center shank with adjustable footpiece
- Wheel & Tire:** 6 Bolt hub and spindle assy. with 9.5L x 15" 8 ply tire

MODEL #	CUT. WIDTH	NO. OF BLADES	WT.
VWT24-16	5' 8" - 7' 0"	16	2,480#
VWT24-18	7' 2" - 8' 6"	18	2,600#
VWT24-20	7' 2" - 8' 6"	20	2,680#

DISCS, WHEEL - WIDE "GT" SERIES MED. DUTY PULL TYPE



FEATURES:

- Frame:** 4" x 4" x 1/4" Structural tubing
- Hitch:** Self leveling, spring cushioned with hand crank
- Gangs & Bearings:** 1 1/2" Square gang axles with greaseable trunnion mounted, double sealed bearings with wear guards
- Gangs:** Adjustable - front 12° to 22° - rear 9° to 21°
- Blades:** 24" x 6mm notched or plain, 9" spacing
- Scrapers:** Standard, adjustable individually or by gang
- Wheels & Tires:** 4 - 6 Bolt hub and spindle assy. 4 - 9.5L x 15" 8-ply tires
- Hydraulics:** 3 1/2" x 8" Cylinder with depth control and hoses
- Shank:** 1" x 3" Center shank
- Rear Hitch:** Standard equipment

MODEL #	CUTTING WIDTH	NO. OF BLADES	NO. OF WHEELS	WT.
GT-24T	9' 2"	24	4	3,300#
GT-28T	10' 8"	28	4	3,700#
GT-32T	12' 2"	32	4	4,140#
GT-36T	13' 8"	36	4	4,360#

Built By: **BWI** implement

DISCS, WHEEL

Offset Pull Type "300" & "500" Series For light and medium tillage conditions

The **Gearmore 300 Series Offset Discs** are ideal for light and medium tillage conditions. We offer sizes from 5' - 3" to 9' for vineyards, berries, narrow row orchards, general field cultivation, etc. The offset design enables maximum penetration and even tillage of soil. Heavy construction with 4" x 3" x 1/4" frame, 1 1/8" axles, 22 inch diameter blades in notched or plain, self leveling hand crank, and double sealed bearings. Built in the West for tough, western conditions.



MODEL #	G302	G303	G304	G305	G306	G307
Width:	5' 3"	6' 0"	6' 9"	7' 6"	8' 3"	9' 0"
No. of Blades:	14	16	18	20	22	24
H. P. Req'd:	35 - 45 H.P.	40 - 55 H.P.	40 - 55 H.P.	45 - 60 H.P.	50 - 65 H.P.	55 - 70 H.P.
Weight:	1,400#	1,500#	1,600#	1,700#	1,800#	1,900#

DISCS, WHEEL - OFFSET PULL TYPE "500" SERIES

The **Gearmore Low Profile Offset Discs** are of rugged design for deep tilling in all soil conditions. We offer the most popular widths of 6' - 9" to 12', for orchard and general tillage operations. The offset design enables maximum penetration and even tillage of soil. Heavy construction with 1 1/2" square gang axles, 24" diameter blades in notched or plain, self leveling hand crank and trunnion mounted, sealed bearings. Built in the West for tough, western conditions.



MODEL #	CUTTING WIDTH	NO. OF BLADES	FRAME	NO. OF WHEELS	H.P. REQ'D	WT. PER FT.	WT.
G501	6' 9"	18	4" x 4" x 1/4"	2	50 to 70 H.P.	325 lbs.	2,430#
G502	7' 6"	20	4" x 4" x 1/4"	2	55 to 75 H.P.	330 lbs.	2,600#
G503	8' 3"	22	4" x 4" x 1/4"	2	60 to 80 H.P.	335 lbs.	2,800#
G504	9' 0"	24	4" x 4" x 1/4"	2	65 to 85 H.P.	345 lbs.	3,100#
G505	9' 9"	26	4" x 4" x 1/4"	2	70 to 90 H.P.	370 lbs.	3,600#
G506	10' 6"	28	4" x 6" x 1/4"	2	75 to 100 H.P.	390 lbs.	4,100#
G507	12' 0"	32	4" x 6" x 1/4"	4	80 to 120 H.P.	400 lbs.	4,800#

Add "W" to model number for weed abatement applications

Built By: **BWImplement**

Offset Pull Type "700" & "900" Series

For finish tilling in all soil conditions

DISCS, WHEEL

DISCS, WHEEL - HEAVY DUTY OFFSET "700" SERIES



The *Gearmore Heavy Duty Offset Finishing Discs* are of rugged design for finish tilling in all soil conditions. We offer two widths 15' - 6" and 16' for general tillage operations. The offset design enables maximum penetration and even tillage of soil. Heavy construction with 1 1/2" square gang axles, 26" or 28" diameter blades in notched and plain, self leveling hand crank, and trunnion mounted sealed bearings. Built in the West for tough, western conditions.

MODEL #	CUTTING WIDTH	NO. OF BLADES	FRAME	NO. OF WHEELS	TRACTOR H.P. REQ'D	WT. PER FOOT	WT.
G704-9	15' 6"	42	6" x 8"	4	80 to 150 H.P.	610 lbs.	9,140#
G705-9	16' 0"	44	6" x 8"	4	90 to 160 H.P.	580 lbs.	9,220#

DISCS, WHEEL - HEAVY DUTY OFFSET "900" SERIES



- FEATURES:**
- Frame & Tongue:** 4" x 8" Structural tubing with hand crank
 - Hitch:** Hydraulic adjusted for easy tractor hook-up
 - Gangs & Bearings:** 2 1/4" Square gang axles with greaseable trunnion mounted triple sealed bearings with additional external seals
 - Gang Beams:** 8" x 8" Structural tubing
 - Blades:** 32" Diameter x 9.5 mm notched front and plain rear with 13" spacing
 - Scrapers:** Heavy duty high tensile steel
 - Wheels:** Dual with 8 bolt hubs and spindles
 - Tires:** 4 - 12L x 15 8 Ply

MODEL #	CUTTING WIDTH	NO. OF BLADES	H.P. REQ'D	WT.
G904	15' 3"	28	160 to 250 H.P.	12,530#
G905	16' 4"	30	170 to 265 H.P.	13,200#
G906	17' 5"	32	180 to 280 H.P.	13,600#

Built By: **BWI**Implement

DUSTERS

3-Point Hitch
To control mildew organically

FEATURES G2V:

- Requires only 15 PTO horsepower to operate
- All gear drive for low maintenance
- Mechanical agitation for even flow
- High wind velocity for maximum coverage
- Adjustable distribution nozzles
- Application rates from 10 to 100 lbs. per acre



MODEL G2V



MODEL S420

FEATURES S420/S530:

- Large capacity polyethylene hopper with hinged vented cover
- Wrap-a-round tubular steel frame isolates and supports hopper
- Aluminum fan housing and steel turbine fan
- All gear drive for low maintenance
- Wind velocities up to 180 M.P.H.
- Manual rate control allows for setting lbs./acre
- Application rates up to 80 pounds per acre
- Minimum rate allowable is 8 lbs. per acre
- Mechanical agitation for even flow
- Lever control, reachable from tractor seat, allows operator to set rates and to turn the dust on & off
- Adjustable fishtail nozzles



MODEL S530

MODEL #	HOPPER CAPACITY	FAN DIA.	WIND VELOCITY	ROW WIDTH	WIDTH	HEIGHT	DEPTH	FISHTAIL EXT.	WIDTH W/ FISHTAILS	WT.
G2V	150 lbs.	12"	150 MPH	4' - 6'	17"	42"	24"	D.N.A.	40"	150#
S420-G	300 lbs.	15 3/4"	150 MPH	6' - 8'	37"	48"	48"	Optional	37"	320#
S530	400 lbs.	19 3/4"	180 MPH	8' - 12'	37"	58"	48"	Yes	72"	390#
S530N*	400 lbs.	19 3/4"	180 MPH	6' - 8'	37"	58"	48"	No	37"	380#

* Same narrow fishtails as S420

DUSTERS, ROW CROP & TRAILER VINEYARD

**5 ROW SHOWN WITH
OPTIONAL PARKING
STANDS**



Gearmore Row Crop Sulfur Dusters feature all-gear drive provides maximum performance with low maintenance. Dust is accurately applied with easy to set application rates. The large 400 lb. capacity polyethylene hopper allows dusting of many acres between "re-fills".

The booms are available for 5 to 12 rows with adjustable nozzles to insure accurate dust placement on the plant foliage. Our Row Crop Sulfur Dusters have successfully controlled mildew on strawberries, tomatoes, watermelons, pumpkins, cantaloupes, peppers, cucumbers, and many other crops. Sulfur has been proven to be the most effective way to control powdery mildew.

DUSTER FEATURES:

- Cat. I & II, 3-point hitch
- Wind velocities up to 180 M.P.H. at manifold
- Manual rate control allows for setting the pounds per acre
- Mechanical agitation for even flow
- Lever control, reachable from tractor seat, allows operator to turn the dust on and off
- Available in 5, 10, & 12 row, hydraulic foldaway booms
- Adjustable nozzles allows for angling to the foliage

MODEL #	DESCRIPTION	BOOM LGTH	MAX. NOZ. CENTERS	WT.
S530RC-5HF	5 Row Duster	31' 2"	68"	400#
S530RC-10HF-3MT	10 Row Duster	41' 2"	48"	470#
S530RC-12HF-3MT	12 Row Duster	41' 2"	40"	500#

DUSTER, TRAILER



Our *Trailer Duster* now features new attachments as standard equipment. An electro hydraulic cylinder with control box for adjusting from the tractor. Also, a hydraulic motor to control the speed of the full length spiral conveyor and agitation system. This insures uniform, accurate distribution of the dust.

FEATURES:

- High performance, precision balanced, all-steel centrifugal turbine fan
- Swivel distribution nozzles adjust for vines and trees
- Full hopper length, large diameter agitator feeds spiral conveyor in bottom of hopper
- Tongue length and tire width are adjustable
- Wide angle constant velocity driveshaft
- Application rates from 5 to 100 lbs. per acre
- Separate 8 gallon (30 liter) fresh water safety tank

MODEL #	HOPPER CAPACITY	MIN. H.P.	VOLUME OF AIR	AIR SPEED	HEIGHT	WIDTH	LENGTH	TIRES	WT.
MAXI600-SPC	1,000 lbs.	40 H.P.	3,180 CFM	420 MPH	50"	50" to 68"	110"	9.5Lx15-8Ply	940#

FORKS

Bucket & Trash Forks

Tools to make your loader more productive

Bucket Forks are a quick, easy way to turn your loader bucket into a forklift. Mounts in seconds to most loader buckets without tools. Forks are equipped with handles for ease in mounting and spacing adjustments. Both forks now have baked-on powder coated paint for rust-free durability and long lasting glossy finish.

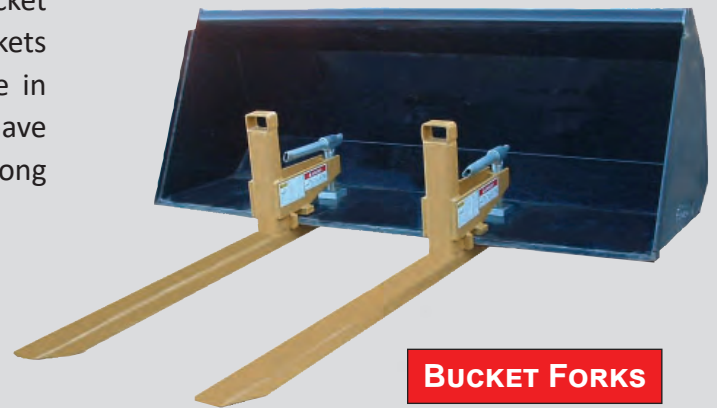

Not recommended on backhoes/wheel loaders/skid steers

MODEL #	CAPACITY (LBS.)	FORK DIMENSION	WT.
1000	1,000 lbs.	2" x 3" x 32"	90#
2000	2,000 lbs.	2" x 3" x 36"	110#
3000	3,000 lbs.	2" x 4" x 42"	190#
4000	4,000 lbs.	2" x 4" x 42"	220#
6000	6,000 lbs.	3" x 5" x 48"	250#

TRASH FORKS

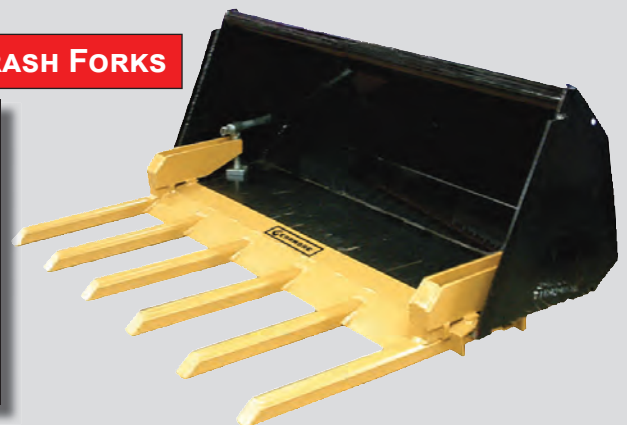

MODELS:	GTF48	GTF54	GTF60	GTF66	GTF72
Bucket Size:	48"	54"	60"	66"	72"
Width:	46"	52"	58"	64"	70"
Tines:	5	5	6	6	7
Approx. Space Between Tines:	8 ½"	10"	8 ½"	10"	9"
Weight:	160#	170#	180#	195#	210#

A loader bucket is great for moving soil, but handling trash is a problem. Our **Trash Forks** are an economical and easy mount solution to this problem. This handy tool will make moving tree branches and other debris an easy task.

These **Clamp-on Bucket Bale Spears** are a quick and handy tool to convert your loader bucket into bale spears. The units have a capacity of 3000 pounds and can handle square or round bales.

BALE SPEARS

FEATURES:

- 2 Heavy screw-lock clamp brackets w/zinc plated handle/screw assemblies
- 2" Square, ¼" wall tubing by 20" long tines
- Clamps fit deep in the bucket for added strength
- Clamping brackets placed near bucket side plates for added strength
- Spear length - 41", diameter - 1 ⅝"
- Overall length - 56"
- 1 ¼" Opening for bucket cutting edge

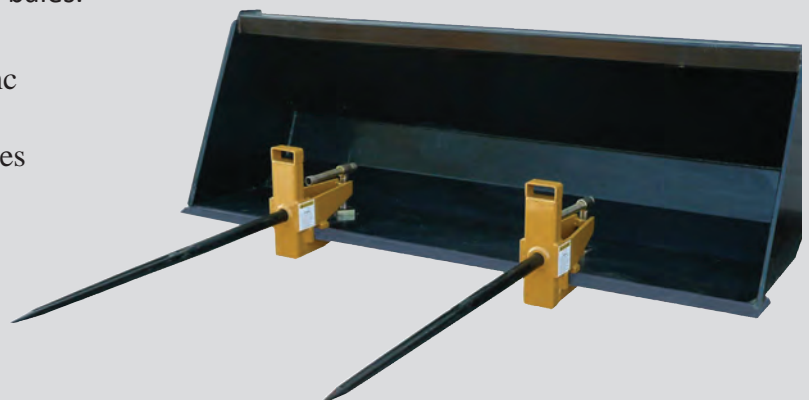

All Forks and Bale Spears come with sliding handle screw and swivel locking plate. They are zinc coated for easy operation and to prevent rust.

MODEL #	DESCRIPTION	CAPACITY	WT.
CBS-3000	Pair of Bale Spears	3,000 lbs.	135#

3-Pointed Mounted

For lifting without the expense of a forklift

FORKS

ADJ. TINE FORKS MODEL 3548

ECONOMY FORKS MODEL 1200

STD. DUTY FORKS MDL. 1500 & 2000-3PT

CAT II
A. S. A. E.
QUICK
HITCH
COMPATIBLE



Cat. I
A.S.A.E.
Quick Hitch
Compatible



Cat. I
A.S.A.E.
Quick Hitch
Compatible



FEATURES:

- 1200, 1500, 2000, 3500 lb. capacity
- 41" fork length for 1200, 1500 and 2000 models
- 48" fork length, fork length for 3548
- Adjustable fork widths, for 3548 models

MODEL #	CAP.	FORK WIDTH (CENTER TO CENTER)	FORK THICKNESS	FORK LENGTH	WT.
1200	1,200 lbs.	26"	2" x 4" x 3/16" tube	41"	90#
1500	1,500 lbs.	26"	1" x 4" solid	41"	160#
2000-3PT	2,000 lbs.	26"	1 1/4" x 4" solid	41"	180#
3548 Cat. II	3,500 lbs.	10" to 36"	1 1/4" x 4" solid	48"	315#

FORKS, BUCKET

The **Gearmore Bucket Forks** allows you to turn your tractor into a forklift in seconds. Our simple safety lock brackets are welded to your bucket. You then curl down the bucket and drive into the forks. Next level the bucket and the forks lock into place.

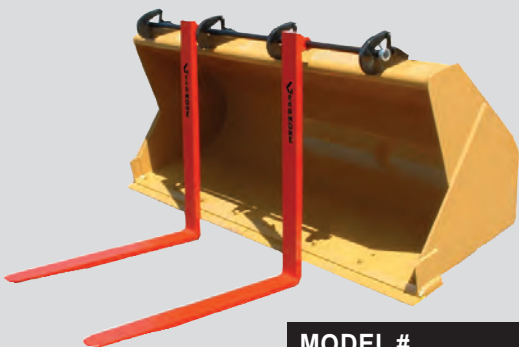

Safety Lock
System

MODEL #	12 UNIV	25 UNIV	40 UNIV	60 LB	60 UNIV	80 UNIV	110 UNIV*
Max. Load Cap. Tine Ct:	1,200 lbs.	2,500 lbs.	4,000 lbs.	6,000 lbs.	6,000 lbs.	8,000 lbs.	11,000 lbs.
Bucket Opening up to:	23"	32"	40"	40"	49"	54"	67"
Tine Height**:	31"	38"	46"	46"	55"	61"	73"
Tine Length:	36"	36"	42"	46"	46"	48"	60"
Adj. Width:	60"	60"	72"	72"	72"	72"	84"
Weight:	225#	240#	330#	400#	435#	690#	960#
Rod Size:	1 1/4" x 5'	1 1/4" x 5'	1 1/4" x 6'	1 1/2" x 6'	1 1/2" x 6'	1 3/4" x 6'	2" x 7'
Tine Size:	1" x 4"	1 3/8" x 4"	1 3/8" x 4"	1 3/4" x 4"	1 3/4" x 4"	2" x 5"	2" x 6"
No. of Brackets:	3	3	4	4	4	4	4

* By adding a 3rd tine, capacity is 16,500 lbs. and by adding a 4th tine, capacity is 22,000 lbs.

** Deduct 2" to calculate center of rod bushing height.

These handy compact **Fork Attachments** can make your tractor/loader into a low cost forklift. The forks feature lockable tines and slotted rails. The solid tines are made of Boron Steel and then are heat treated.

FEATURES:

- Load capacities of 2400
- Fits compact JD QA 200/300 loader
- Adjustable and lockable rail style forks
- Equipped with high visibility load guard



WARNING: The loader mounted fork attachments are specifically designed to engage and load palletized materials. Do not use forks to handle large loads, such as bales, posts, etc., and avoid carrying loose or shiftable loads, as they can fall or roll back onto operator causing serious injury or death.



MODELS:	832530
Lift Cap:	2,400 lbs.
Fork Length:	42"
Tine Size:	1.18" x 3" Solid
Loader Mounts:	Fits JD compact loaders 200/300 w/quick change attach. carrier
Weight:	280#

Available For Universal, John Deere & Global / Euro Quick Attach

FEATURES:

- Available in 2,300, 3,750, 4,000 & 5,500 lb. cap.
- Fork tines available in 42" & 48" length
- Exclusive load retention hook for securing and positioning pallet loads
- Solid tine positioning w/spring loaded toggle operation
- Easy loading with tapered tines

3750 LB. CAP.

2300 LB. CAP.



The new heavy duty frames are designed to handle both the 2,300, 4,000, 3,750, and 5,500 lb. capacity forks. The 10 gauge brickguard offers outstanding strength and smooth surface for protection and less load damage. Also, the convenient non-skid step offers easy operator access, except 2,300 lb. capacity. The tine end visibility is excellent.

CODE #	DESCRIPTION	CAPACITY	TINE LENGTH	WT.
107283/106220	SSL QA Compact	2,300 lbs.	42"	270#
107283/106222	SSL QA Compact	2,300 lbs.	48"	285#
17380 / 102030	SSL QA Fork Assy.	3,750 lbs.	48"	480#
832435	JD QA Fork Assy.	4,000 lbs.	48"	359#
17380 / 102034	SSL QA Fork Assy.	5,500 lbs.	48"	500#
832460	Euro Global Fork Assy.	5,500 lbs.	48"	393#

Drag or Lifiable

Aggressive, light or minimum action positions

CHAIN HARROWS

5/8" TINES DRAG CHAIN HARROWS



DRAG - AVAILABLE IN ALL SIZES

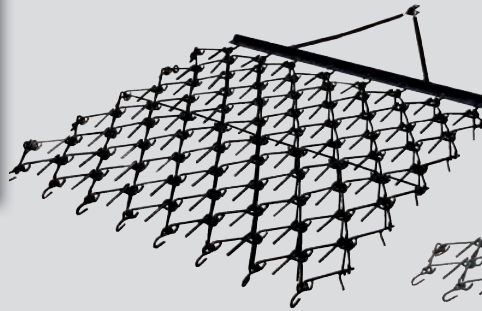

LIFTABLE - AVAILABLE IN 4X4, 6X6 & 8X6

Cat. I
A.S.A.E.
Quick Hitch
Compatible

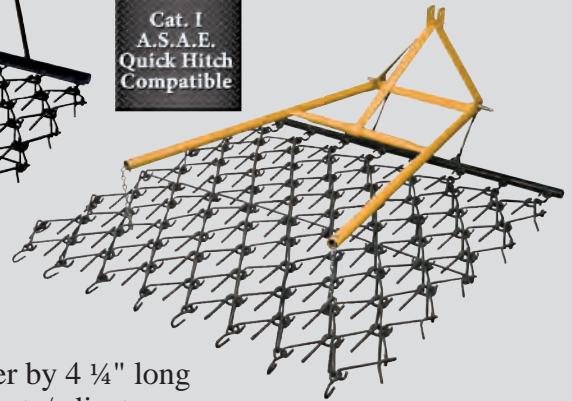

FEATURES:

- 2" Pipe drawbars w/5/8" chain
- Tines 5/8" diameter x 6" long
- Cold formed tines eliminate breakage
- Evenly works ground regardless of terrain
- No parts to lubricate or adjust
- Can be operated at speeds up to 8 M.P.H

PASTURE RENOVATION & MAINTENANCE

Spreads and incorporates manure, thatches dead growth, aerates soil, increases moisture penetration and renovates pastures by preparing soil for seeding while stimulating existing growth.

DIRT & GRAVEL MAINTENANCE

For ball diamonds, race tracks, dirt and gravel roads, rodeo arenas, etc. Smooths rough spots, fills holes and incorporates moisture.

GRASS & TURF MAINTENANCE

For parks, golf courses, and playing fields. Incorporates seed, dethatch turf, and aerates soil. Pulls out dead material without disturbing new growth.

ALL TILLAGE APPLICATIONS

Prepares firm, level seedbed in combination with drills, cultivators and discs. Can be used to break up crusts and clods. Incorporates herbicides evenly because flexible design assures uniform depth.

Flexible Two-Way Design For Optimum Debris Clearance

Pull backwards for light penetration Pull forward for deep penetration

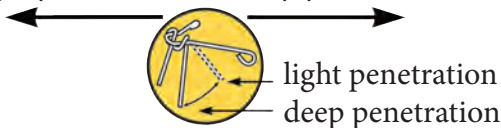

FEATURES:

- Tines 1/2" diameter by 4 1/4" long
- No parts to lubricate/adjust
- Offset tines eliminate ridges
- Evenly works ground regardless of terrain
- Cold formed tines eliminate breakage
- Can be operated at speeds up to 8 M.P.H

NOTE: 4' Lift Harrow Not Cat. I Quick Hitch Compatible

MODEL #	TYPE	DESCRIPTION	WT.
G4-3P-H4x4-1/2	3-Pt.	4' Wide x 4' Deep	140#
D4-4x6-5/8	Drag	4' Wide x 6' Deep	150#
D6-6x8-5/8	Drag	6' Wide x 8' Deep	310#
G6-3P-6x6-5/8	3-Pt.	6' Wide x 6' Deep	280#
D8-8x8-5/8	Drag	8' Wide x 8' Deep	373#
G8-3P-8x6-5/8	3-Pt.	8' Wide x 6' Deep	351#
D10-10x8-5/8	Drag	10' Wide x 8' Deep	490#
D12-12x8-5/8	Drag	12' Wide x 8' Deep	634#

Drawbars Only		
MODEL #	WIDTH	WT.
D4	4'	26#
D5	5'	30#
D6	6'	36#
D8	8'	50#
D10	10'	60#
D12	12'	70#
D1D	Adapter Kit	

Chain Sections			
MODEL #	WIDTH	DEPTH	WT.
H4X4-1/2	4'	4'	70#
H5X4-1/2	5'	4'	86#
H6X4-1/2	6'	4'	105#
H6X6-1/2	6'	6'	157#
H6X8-1/2	6'	8'	209#
H8X6-1/2	8'	6'	209#
H10X4-1/2	10'	4'	174#

VARIABLE ACTION FOR EVERY APPLICATION

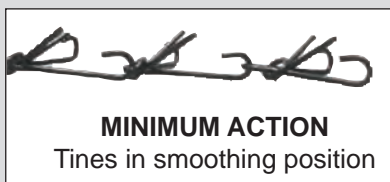

HARROWS, ROTARY & QUICK HITCH

FEATURES:

- Cat. I, 3-point hitch
- 2" x 2" Square tubing wheel with 5 spokes
- 5 1/2" High carbon teeth
- Sealed bearing hub
- Heavy 3" x 4" tubing frame
- 8" Bolt-on replaceable teeth
- Angled teeth provide trash clearance

Now with
replaceable teeth



The GRH Series of **Rotary Harrows** was designed to aerate soil and pull weeds. The unique turning action allows the harrow to level soil by redistributing it inward. Excellent tool for moving high spots away from fences and walls. Levels, floats and breaks up clods. The ideal product to use in arenas.

MODEL #	DESCRIPTION	WT.
GRH5B	Rotary Harrow, 5 Foot	240#
GRH6B	Rotary Harrow, 6 Foot	290#

Fits Cat. 1 or 2, the quick, safe way to attach implements

QUICK HITCHES

Our Cat. I & II **Quick Hitches** were designed to make changing implements easier, safer and faster. Thus, eliminating the lifting and moving heavy implements into position for mounting to the tractor. You can safely change implements in seconds.

FEATURES:

- Operator can engage and secure implements more easily
- Reduces chance of personal injury as no need to put yourself between the tractor and the implement, except for attaching driveshafts
- Automatic lock with quick release handles
- Optional hydraulic top link cylinders are available for easier hook-up
- Additional bushing kits for each implement are available

Cat. I & II
A.S.A.E.
Quick Hitch
Compatible

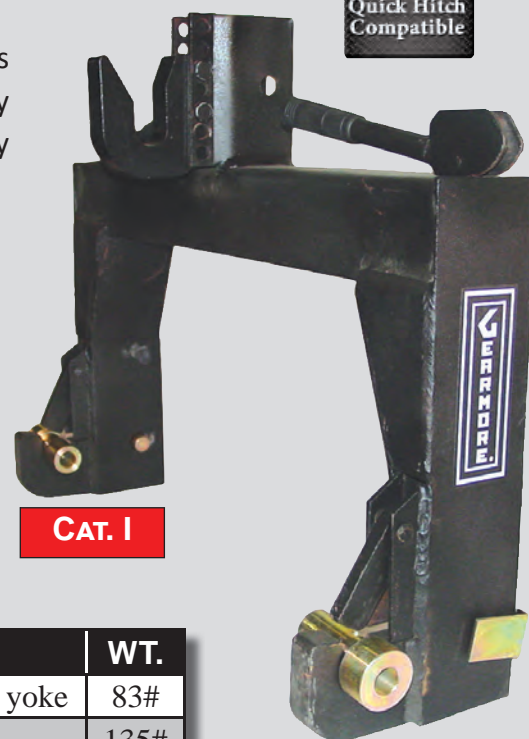

CAT. I

MODEL #	DESCRIPTION	WT.
862830	Cat. I - Complete with 7/8" shouldered bushings and swivel yoke	83#
862845	Cat. II - Complete with 1 1/8" mounting pins & adapter bushings - 100 H.P. Max.	135#

For Hedging Orchards

HEDGER/ TOPPER/SKIRTER

MODEL P1100-O

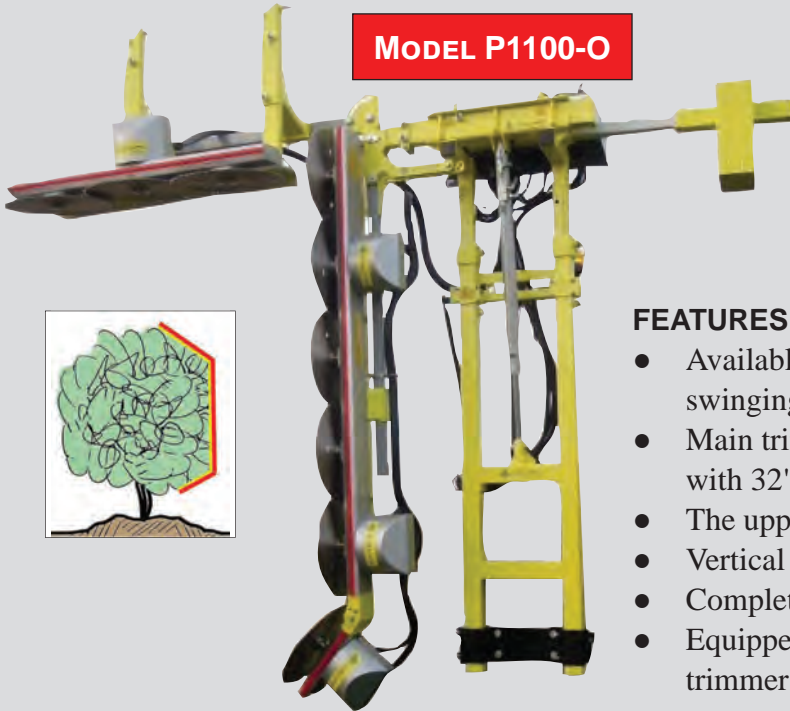

These unique **COLLARD Hedgers** were designed for half row trimming of orchards and can be used on a number of different crops. The heart of this hedger is the unique lightweight aluminum alloy element that provides a rugged rust-proof framework for the cutting blades. The units feature two different cutting systems - saw blades or dual swinging knives.



FEATURES:

- Available with 18" diameter S.S. saw blades or swinging knives
- Main trimmer beam has hydraulic up and down with 32" stroke cylinder
- The upper element manually adjusts 12" vertically
- Vertical breakaway system to protect equipment
- Complete hydraulic distributor, hoses, and "JIC" couplers
- Equipped with electro-hydraulic joystick controls for precise trimmer adjustments

ORDER CODE	MODEL #	VERTICAL CUT	HORIZONTAL CUT	NO. OF BLADES	HYDRAULIC REQUIREMENTS	WT.
01341350	P1100-O	90"	48"	9	12 G.P.M.@2600 PSI	1,200#

NOTE: The maximum cutting height is approximately 10 foot.

HEDGER TOPPER

The **COLLARD Hedger/Topper** was designed to hedge, top trees and bush crops. Easy to operate with electric controls. The cutting bar length is 6 feet and additional blades can be added for longer cuts. This unit is great for orchard hedging, topping and fence line maintenance.



FEATURES:

- Dual hydraulic motors for added power
- Standard cutter bar length 6.8 feet
- Vertical reach of 20 feet
- Flat topping height of 13 feet
- Electro hydraulic controls
- Hedger comes with all hoses, fittings and JIC couplers
- Flail knives are optional
- Includes 3-point hitch, PTO driven hydraulic Power Pack

Built By:



MODEL #	DESCRIPTION	REACH	TOPPING	WT.
TA400	Hedger/Topper 5 Blade	20 Ft.	13 Ft.	860#

Allows total control of orchard profile



The **COLLARD Hedger** is a total pruning system for orchards. Features an adjustable pruning system to hedge, top and skirt orchards. Allows growers to maximize production and reduce pruning costs. By reducing heavy crop set limb damage, opens middles for better sunlight, cleans out lower branches to reduce herbicide damage and allows passage of tractors without limb breakage.

FEATURES:

- 7 cylinder hydraulic system which allows for many different applications
- Electro hydraulic controls
- 18" Diameter S.S. saw blades are standard with optional flail knives for green material
- Designed so that blades throw much of the brush into the rows, instead of dropping into the tree canopy
- Effective trimming for both nut and fruit orchards
- Cut lengths per side of 8, 9.4, 10.7 or 12 ft.
- 6 Blades shown - optional 5, 6, 7, 8 and 9 blades per side
- Maximize production and reduce pruning cost with better management of your tree canopy

- Reduce heavy crop set limb breakage
- Clean your lower hangers to reduce herbicide damage
- Open middles for better sunlight - improve harvest conditions
- Hedge when you want
- Allow passage of tractors without limb damage or operator risk

This special 3-pt. hitch PTO. driven **HYDRAULIC POWER PACK** was developed as a self-contained power system which eliminates using the tractor hydraulics. The hydraulic oil will stay cooler with no loss of power to the hedger. The Power Pack features 3 hydraulic pumps, one for the hydraulic cylinders and one for each blade transmission housing. The 30 gallon oil reservoir includes return filter with cartridge and oil level gauge. Also included is oil cooler, driveline and hoses. This Power Pack is now standard.



ORDER #	MODEL #	DESCRIPTION	APPROX. WT.
01370800 - 2448	P2000AH*	Hedger with Power Pack	2,330#

NOTE: The models above are for hedgers only, advise the number of blades required.

Built By:



For Skirting Orchards

Manual angle adjustment

SKIRTERS

Model P1000SK



FEATURES:

- Skirter is strong but lightweight and easy to operate
- Double tubing socket bracket to mount on tractor frame
- High speed stainless steel blades - 18 7/8" long
- Sliding horizontal tubing extends 20" to right side, manual
- High capacity 10cc hydraulic motor
- Sliding vertical tubing 20" up/down, manual
- Cutting housing is 35" long and angles down manual 0° to 45°
- Blade housing has safety break away system

This **COLLARD Skirter** trims half rows with 2 high speed stainless steel blades. The heart of this Skirter is the unique lightweight aluminum alloy element that provides a rugged rust proof frame work for the cutting knives. The COLLARD Tree Skirter is a fast, effective way to keep lower branches off the ground. The main reason to skirt trees is to prevent easy access of all types of pests. Another important reason to skirt is to provide clearance for other operations, such as spraying and mowing.

ORDER #	MODEL #	CUT. LENGTH	NO. OF BLADES	HYD. REQUIREMENTS	SHIP WT.
013700950	P1000SK	35"	2	8 G.P.M.	410 lbs.

SKIRTERS

Model P2000SK



For skirting orchards - hydraulic adjustment

This **COLLARD Skirter** trims two half rows with 6 high speed swinging stainless steel knives. The heart of this Skirter is the unique lightweight aluminum alloy element that provides a rugged rust proof frame work for the cutting knives. The COLLARD Tree Skirter is a fast, effective way to keep lower branches off the ground. The main reason to skirt trees is to prevent easy access of insects and pests of all types. Another important reason to skirt is to provide clearance for other operations, such as spraying and mowing.

FEATURES:

- Skirter is strong but lightweight and easy to operate
- Double tubing socket bracket to mount on tractor frame
- High speed S.S. double cutting edge flail knives
- High capacity 15cc hydr. motors with ribbed belts
- Equipped with electro hydraulic joystick controls
- Wide range of adjustments for positioning skirts to each grower requirements
- Up/down 2 hydr. cylinders with 20" stroke, ea. side
- In/out hydr. cylinders with 20" stroke, ea. side
- Three swinging knives per housing with cut of 50"

ORDER #	MODEL #	CUT LENGTH @ 45°	NO. OF BLADES	HYD. REQUIREMENTS	SHIP WT.
01370900	P2000SK	Max.-16' Min.-10'-7"	3 per side	10 G.P.M.	680 lbs.

*Advise your row spacing

Built By:



COLLARD



NEW



4 IN 1 BUCKETS

42" and 48" widths models available. Functions as a loader bucket, clam, grapple, dozer, box scraper, and bottom dump bucket. Has strong hinges and pins to distribute load.

Specifications	2008270	233333
Width (overall)	42"	48"
Height (overall)	19.7"	19.7"
Length	27.7"	27.7"
Clam Opening	18.2"	18.2"
Weight (lbs)	250#	281#
*38" special order		



ROCK BUCKETS

Designed to collect rocks and debris, allowing soil to sift through. Rake design allows for fast clean-up, ground leveling and gathering materials away from buildings and obstructions. Leave the dirt and pay less at the land fill!

Specifications	19500
Width (overall)	42"
Height (overall)	15"
Length (overall)	25"
Tine Spacing (between tines)	2"
Tine Rod Diameter	1.13"
Weight (lbs)	184#



BRUSH GRAPPLES

Aggressive grapple made of high strength steel for maximum performance and durability. Cylinder guard design protects cylinder while preventing build-up of debris. Great for cleaning up and transporting branches, brush, and limbs.

Specifications	235962	235965
Width (overall)	42"	48"
Height (overall)	26"	26"
Length (overall)	31"	31"
Grapple Opening	29"	29"
Weight (lbs)	256#	275#



ROOT GRAPPLES

The aggressive tine shanks root out objects below ground level. The wide grapple opening allows for gathering a large amount of brush and debris. The hydraulically operated grapple locks the material in place and stabilizes it for transport.

Specifications	124429	235928
Width (overall)	42"	48"
Height (overall)	28.4"	28.4"
Length(overall)	26.8"	26.8"
Tine Spacing	8.5"	8.5"
Grapple Opening	32"	32"
Weight (lbs)	268#	276#



AUGER DRIVES

The X1500 hydraulic digger is the most trouble free digger on the market. The unit features high torque system and has 2" hex shaft. Digger comes with CII mount.

Specifications	X1500
Min. Hyd. Flow	8 G.P.M.
Max. Hyd. Flow	16 G.P.M.
Max. Auger Diameter	30"
Output Shaft	2" Hex
Auger Diameters	6" - 30"



PALLET FORKS

High strength lightweight frame for large 2300 pound pay loads. Open guard for excellent visibility. Patented load retention ring. Available in tine length of 42" & 48".

Specifications	12331/ 106220	12331/ 106222
Frame Width	40"	40"
Frame Height	31"	31"
Fork Thickness	1"	1"
Fork Width	3"	3"
Fork Length	42"	48"
Wt. Frame & Forks	210#	225#

Other implements and sizes are available on request.



SIFTING BUCKET

Designed to collect rocks and debris, allowing soil to sift through. Rake design allows for fast clean-up, ground leveling and gathering materials away from buildings and obstructions. Leave the dirt and pay less at the land fill!



4 IN 1 BUCKET

60" and 72" models available. Functions as a loader bucket, clam, grapple, dozer, box scraper, and bottom dump bucket. Has strong hinges and pins to distribute load. The bottom dump buckets allows the operator to dump into high side board trucks.



ROOT RAKES

The aggressive tine shanks root out objects below ground level. The wide grapple opening allows for gathering a large amount of brush and debris. The hydraulically operated grapple locks the material in place and stabilizes it for transport.



BRUSH GRAPPLES

Aggressive grapple made of high strength steel for maximum performance and durability. Cylinder guard design protects cylinder while preventing build-up of debris. Great for cleaning up and transporting branches, brush, and limbs.



HYDRAULIC DIGGER

The D450 hydraulic digger is the most trouble free digger on the market. The unit features an in line sealed planetary gear reduction drive design. This clean, effective system ensures long trouble free usage. Digger comes with Q.A. brackets w/cradle.



PALLET FORKS

High strength lightweight frame for large 2,300 pound pay loads. Open guard for excellent visibility. Patented load retention ring. Class II ITA forks with positioning lock pin.

Specifications	108603
Width (overall)	55.3"
Height (overall)	21.5"
Length (overall)	23.5"
Tine Spacing (between tines)	2.0"
No. of Tines	18
Tine Rod Diameter	1.13"
Weight (lbs)	300#

Specifications	108196	108198
Width (overall)	60"	72"
Height (overall)	27"	27"
Length w/o Teeth (overall)	28"	28"
Front Length w/o Teeth	15"	15"
Rear Length	14"	14"
Grapple Opening	28"	28"
Weight (lbs)	380#	430#

Specifications	109982	109984
Width (overall)	60"	72"
Height (overall)	28.1"	28.1"
Length(overall)	19.5"	19.5"
Tine Spacing	12"	12"
Grapple Width	57.1"	57.1"
Grapple Opening	32.5"	32.5"
Weight (lbs)	413#	448#

Specifications	108597	108598	108415
Width (overall)	48"	54"	72"
Height (overall)	25.5"	25.5"	25.63"
Length (overall)	30.5"	30.5"	30.5"
Tine Spacing	5.7"	5.7"	5.7"
Grapple Opening	29"	29"	29"
Clamp Force (lbs)	1,100	1,100	1,100
Weight (lbs)	300#	315#	435#

Specifications	D450
Min. Hyd. Flow	5 G.P.M.
Max. Hyd. Flow	10 G.P.M.
Max. Auger Diameter	12"
Output Shaft	2" Round
Auger Diameters	6" 9" & 12"
Wt. of Digger & QA Brkt	264#

Specifications	107283/ 106220	107283/ 106222
Frame Width	45"	45"
Frame Height	28"	28"
Fork Thickness	1"	1"
Fork Width	3"	3"
Fork Length	42"	48"
Wt. Frame & Forks	252#	285#

COMPACTION WHEELS



- Designed for small excavators & backhoes
- Compactor widths of 12", 18", and 24"
- Rims available in 2, 3, and 4 wheels
- Compaction pads abrasion resistant
- Wheel diameters of 22" and 28"
- Compactor weights of 320 to 980 lbs.
- For machine weights of 2,700 to 38,000 lbs.

4-IN-1 BUCKETS



Construction Series shown with optional side cutter & spill guard

- 3 Series in widths of 60", 66", 72", 78", & 84"
- For machine weights - 4,000, 8,000 & 12,000 lbs.
- Long floor design improves cutting edge visibility
- "Hose Saver" spring kit standard, except on compact units
- Unique side cutters on construction series only
- Effective loader bucket for clam, dozer, scraper and bottom dump operations

TRENCHERS



Model 612 For Tractors 20 - 45 H.P.

- 3-Pt. hitch, PTO driven for 15 to 45 H.P. hydrostatic transmission tractors
- Digging depths from 30" to 60" deep
- Digging widths from 3" to 12" wide
- Large discharge auger places soil away from trench
- Built with the best of heavy duty components



Model 330 For Tractors 15 - 30 H.P.

SIFTING/ROCK BUCKETS

66" With Loader Arms

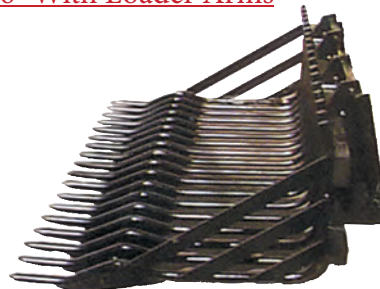

- Widths of 66", 75" and 84"
- Brackets to fit loader arms, Skid Steer and quick attach
- Unique tine design is contoured to cradle the debris and rocks
- Rods are 1 1/4" diameter high alloy steel
- Standard buckets come with 3 1/8" spacing between tines, with the option of 2" spacing



Optional Grapple

Built By:



PA RIPPER BARS

These **Ripper Bars** are excellent for aerating pastures and other ripping applications.

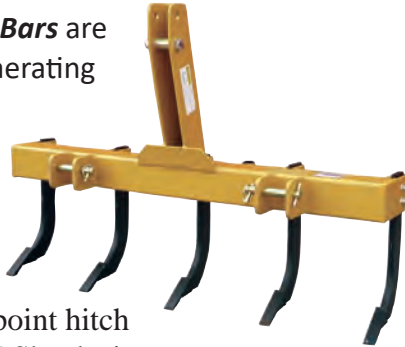

- Cat. I, 3-point hitch
- 5, 6 and 7 Shank sizes
- Rips up to 8" deep
- Shear bolt protection

80-320 ALL-PURPOSE MIXERS

Our economy **Mixer** effectively blends materials including concrete, feed, and fertilizers.



- Cat. I, 540 R.P.M. PT
- Capacity - 11 cu. ft.
- Mixes 1 1/2" sacks of cement
- Single acting cylinder with hose

SC 3-POINT ROLLERS

These **3-Point Hitch Rollers** have excellent maneuverability to smooth and increase the firmness of turf surfaces.



- Available in 60" width with 16" dia. drum
- Or 72" width with 20" dia. drum
- When water is added the 60" weighs 860 pounds, the 72" weighs 1,340 pounds

SC PULL TYPE ROLLERS

Our **Pull Type Rollers** are available with 20" dia. rollers in widths of 60", 72", and 96". When filled with water the rollers are great for packing down loose dirt, newly sown seed and turf.



- Available in roller widths of 60", 72", & 96"
- Heavy duty 1/4" thick roller tubing
- 1 7/16" Full length axle with bearings

TB TOOTH BARS

Our bolt-on **Tooth Bars** are designed to make your loader bucket more aggressive.



- Requires no drilling of bucket
- Special set screws to hold tooth bar in place
- Available for inside bucket widths of 40", 46", 52", 58", 64", & 70"

ADJUSTABLE THUMBS

The **Adjustable Thumb** increases the productivity of backhoes or mini-excavators.



- Four sizes available
- Folds flat against the dipper boom for storage
- Mounting requires welding to backhoe

The **Quick Attach Bracket** for compact tractors allows you to change loader attachments in minutes. Just unlatch the quick attach, back out of one implement and drive into another, flip the locking handles and you are ready to go back to work.

FEATURES:

- The Quick Attach mounts directly to your loader arm and cylinders in minutes
- No special pins or modification to the loader are necessary
- Available for most popular compact tractor loaders
- Weld-on plates are available to convert standard brackets to Quick Attach



Root rakes available in widths of 60", 66" & 72" Available in quick attach only



4 in 1 buckets are available in 60" & 72" widths. Functions as loader bucket, clam, grapple, dozer and bottom dump

ELECTRO HYDRAULIC KIT



Model # EH-100 Electro Hydraulic Valve components for installation on tractor loaders

Gearmore **Electro Hydraulic Components** were developed to obtain a simple, compact way to operate loader mounted hydraulic implements. The mounted electro hydraulic valve is easily operated by a push button switch knob mounted on the tractor loader valve lever. This allows operation of the loader functions and hydraulic implements without moving your hand.

FEATURES:

- Electro hydraulic valve, operates hydraulic functions up to 13.2 G.P.M.
- Easily installed replacement loader knob with pushbutton electric switch
- Valve mounting bracket and hardware

NOTE: Not compatible with regenerative valve circuits

MODEL #	DESCRIPTION	WT.
*EH-100	Electro hydraulic valve components for dealer installation on tractor loader	10#
* Dealer to supply hoses, fittings, and wiring		

"SLE" Series

No tools blade changing system

FLAIL MOWERS

The "SLE" Series of Flail Mowers are the most versatile mower on the market today. Some of the unique features are: models can be easily converted from center mount to offset, giving an additional 9 inches of offset to right. Two types of blades are available; the Y shaped blades for weed and light brush, and the curved duckfoot blade for mowing grass. Best of all, the blades can be changed by hand, no tools necessary! These flail mowers were designed to achieve fine shredding on cover crops, parks, golf courses, pastures and many other applications.



OFFSET POSITION



CENTER POSITION

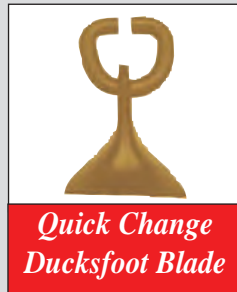

FEATURES:

- Cat. I, ASAE quick hitch compatible
- 45 H.P. gearbox, 540 R.P.M.
- Center mount with 9 inch offset to right
- Available with Y blades for light brush or ducksfoot blades for grass
- Designed for tractors that have 540 R.P.M. PTO speed
- Low profile design for clearing obstruction
- Pivoting 3-point hitch back brace for added strength and to easily offset hitch
- 3 belt final drive with automatic belt tightening idler to provide maximum power to the blades
- Rotor speed - 2,340 R.P.M. with blade tip speed of 8,984 feet per minute
- Internal "saw tooth" cutter bar to reduce size of the shredded material
- 5" Diameter adjustable rear roller
- Two adjustable parking stands to allow easy hook-up to quick hitch tractor
- Safety chain shield in front and rubber rear deflector

MODEL #	MOW WIDTH	OVERALL WIDTH	OFFSET FROM CENTER OF TRACTOR	NO. OF KNIVES	MIN. H.P. REQ'D	WT.
SLE-120	48"	54"	36"	22	20 H.P.	415#
SLE-160	63"	69"	43.5"	30	28 H.P.	525#
SLE-190	75"	81"	49.5"	36	35 H.P.	620#

FLAIL MOWER/ SHREDDERS

"SFG" Series
Center mount, manual/hyd. offset

Our *SFG Series Flail Mower/Shredders* has a number of unique features as they are compact, heavy duty, low profile and offsetable. The two largest shredders are manual offset, return to center with optional hydraulic offset. Two style of blades can be purchased, hammer knives or double Y blades. These blades are also interchangeable on the same shredders. The low profile design of the machine aids when working in tight areas. These are popular mowers in vineyards, berries, roadsides, weed abatement, rental yards, etc.

Cat. I
A.S.A.E.
Quick Hitch
Compatible

SFG155 SERIES
W/OPTIONAL RAKE TEETH



SFG200 SERIES
W/MANUAL OR HYD. OFFSET



Double Y Blade



Hammer Knife

FEATURES:

- Cat. I & II ASAE quick hitch, 540 R.P.M. tractors
- Heavy steel tubing A frame 2" x 3"
- A frame swivel tubing back brace
- Fixed center mount hitch*, offsetable on 185/200
- 80 H.P. gearbox with built-in overrunning clutch
- Low profile belt housing, 23" high for clearance
- Hammer knives shreds brush and prunings up to 2" diameter
- Double Y Blades mow weeds and light brush up to 1" diameter
- Cutting height adjusts from 1" to 4" above ground
- Rotor speed - 2,200 R.P.M.
- Two rows of heat treated re-cutter blades
- Rear hatch adjusts for various types of mowing
- Rear hatch slotted for rake teeth
- Balanced 5 1/2" rotor tubing
- 5 1/2" Diameter rear roller adjusts vertically and horizontally
- 4 Belt final drive with screw tensioning to provide maximum power to the rotor
- Series 6 PTO driveshaft
- Front mounted safety chain
- Side skids

OPTIONS:

- ~ Rake Teeth
- ~ Hydraulic cylinder, offset SFG 185 & 200

**SFG200 can't be true center mount*

MODEL #	WORKING WIDTH	OVERALL WIDTH	MAXIMUM OFFSET*	NO. OF HAMMERS	NO. OF Y BLADES	H.P. REQ'D	RAKE SLOTS	WT.
SFG95	38"	43"	-	6	24	20	6	620#
SFG125	49"	55"	-	8	32	25	8	730#
SFG140	55"	61"	-	10	40	30	9	770#
SFG155	61"	67"	-	10	40	35	10	840#
SFG185*	73"	78"	44"	12	48	40	12	1,005#
SFG200*	79"	84"	48"	14	56	45	13	1,100#

* These shredders come with manual offset, hydraulic offset is optional. Offset shown is the maximum offset from centerline of tractor to the right

NEW

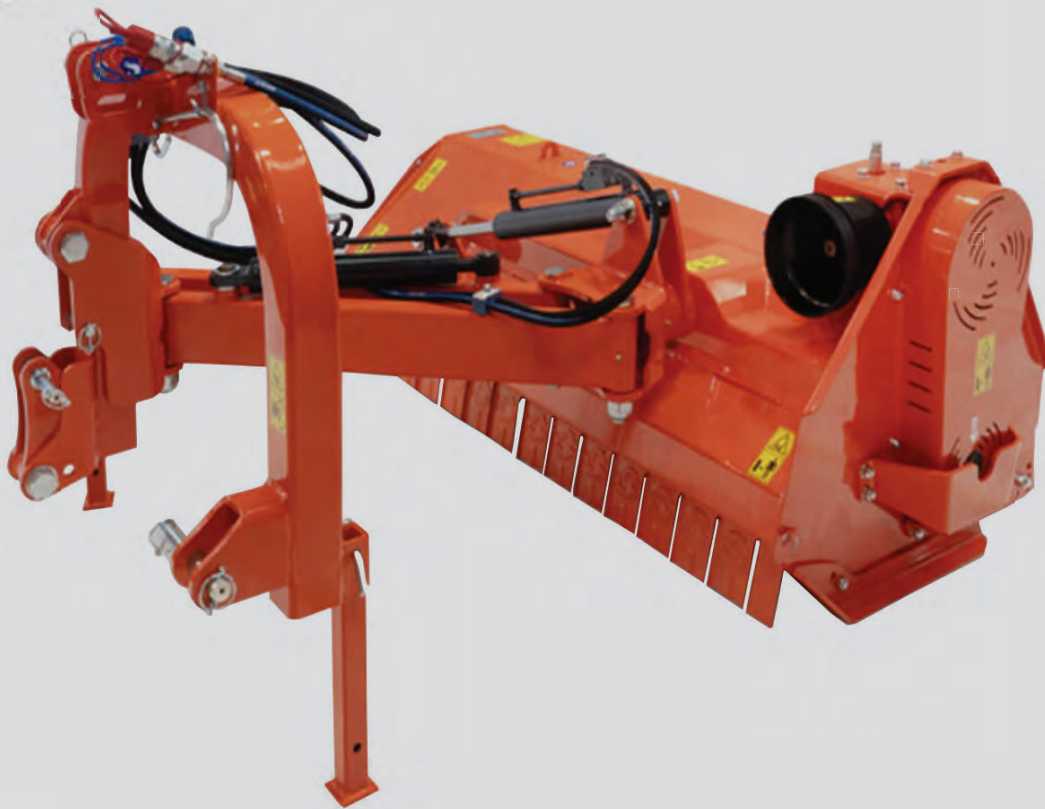

These **Flail Ditch Bank Mowers** were designed for mowing in difficult locations without placing the tractor and operator in unsafe situations. The mowers feature two hydraulic cylinders, one for side shift and one for tilt. The mowers shift to right and tilt down. These units have hammer knives to cut grasses and heavy weeds up to 1 ½" in diameter. Excellent for mowing ditches, tree lines and road right of ways, etc.

FEATURES:

- Cat. I & II 3-point hitch, 540 R.P.M.
- Shreds weeds and grasses up to 1 ½" in diameter
- For tractor horsepower of 30 to 70
- 70 H.P. gearbox with built-in overrunning clutch
- Hydraulic parallel linkage for side shifting
- Hydraulic tilt
- Drop forged hammer knives
- Two rows of heat treated re-cutter blades to shred finer
- 5 ½" adjustable rear roller
- Side skids
- Front and rear mounted metal flaps
- Comes complete with hydraulic hoses to tractor

MODEL #	MOWING WIDTH	OVERALL WIDTH	MAX. OFFSET	NO. OF KNIVES	REQ'D TRACTOR WEIGHT	WT.
MLI 140	55"	61"	85"	20	3,880#	970#
MLI 160	62"	68"	85"	22	4,060#	1,015#
MLI 180	71"	76"	108"	24	4,240#	1,060#

FLAIL SHREDDERS

"GCF" & "S7B" Series Front or rear mount

Our **GCF Series Mower/Shredders** are now designed for front or rear tractor mount. To front mount, just re-bolt the A-frame to the back of the shredder. Equipped with a rear deflector which in open position discharges grass and allows tractor speeds up to 6 MPH, and in closed position contains and further shreds brush to a finer mulch. Just right for use in vineyards, berries, and other narrow row crops. Also used by roadsides, parks, rental yards, and general weed abatement.

"GCF" SERIES



FEATURES:

- Fits Cat. I & II, 3-point, 540 R.P.M. tractors
- HD 72 H.P. gearbox with built-in overrunning clutch
- Hammer knives shred brush & prunings up to 2", and will also mow grass
- Computer balanced vibration free rotor turns at 2,000 R.P.M.
- Adjustable A-frame allows offsetting mower 6" to the right
- Front safety chains provide safety from flying material

MODEL #	MOW WIDTH	OVER-ALL WIDTH	NO. OF KNIVES	MIN. H.P. REQ'D	WT.
GCF45	45"	50"	12	25 H.P.	700#
GCF53	53"	58"	12	30 H.P.	790#
GCF61	61"	66"	15	35 H.P.	920#
GCF69	69"	74"	18	40 H.P.	970#
GCF79	79"	84"	21	45 H.P.	1,030#



Hammer Knife

The Gearmore Mower/Shredders

are the ultimate in flail mowing. The 3 lb. drop forged hammer knives will shred up to 3" diameter branches and yet will mow grass. Just right for use in vineyards, orchards, roadsides, parks, pastures and weed abatement. You will find that these heavy duty machines will give many years of low maintenance usage.

FEATURES:

- Cat. I & II 3-point, 540 R.P.M.
- Reversible front or rear center mount
- Shreds brush or prunings up to 3", constant use 2 1/2"
- Cutting height adjusts from 1" to 4"
- Equipped with rubber rear deflector
- Heavy duty 100 H.P. gearbox with built-in overrunning clutch
- Double row drop forged cutter bars increase shredding of material - replaceable
- Front protection with metal flaps and chains
- Equipped with a "patented" internal rear deflector which in open position discharges grass and allows tractor speeds up to 6 M.P.H.
- In closed position contains and further shreds brush to a finer mulch

"S7B" SERIES



Built by :



MODEL #	MOW WIDTH	OVERALL WIDTH	NO. OF KNIVES	MIN. H.P. REQ'D	WT.
S7B-150	59"	65"	15	50 H.P.	1,170#
S7B-175	69"	75"	18	55 H.P.	1,340#
S7B-200	79"	85"	21	60 H.P.	1,430#
S7B-250	98"	104"	27	70 H.P.	1,720#

"S7C" Series

Hydraulic offset shred brush up to 3'

FLAIL SHREDDERS



"S7C-175 SHOWN"



Hammer Knife

Built by :



OFFSET POSITION

The **Gearmore Mower/Shredders** are the ultimate in flail mowing. The 3 lb. drop forged hammer knives will shred up to 3" diameter branches and yet will mow grass. Equipped with a "patented" internal rear deflector which in open position discharges grass and allows tractor speeds up to 6 M.P.H., and in closed position contains and further shreds brush to a finer mulch. In offset position, the units are ideal for mulching prunings and heavy grass in orchards. Municipalities find these shredders excellent for roadside maintenance.

FEATURES:

- Fits Cat. I (69" - 79") & II (98"), 3-pt. hitch, 540 R.P.M. tractors
- Shreds brush or prunings up to 3"
- 100 H.P. gearbox with built-in overrunning clutch
- Hydraulic parallel linkage side shift from offset to center mount
- Specially designed drop forged hammer knives
- Double row of drop forged cutter bars to increase the shredding of material - replaceable
- Equipped with a "patented" internal rear deflector which in open position discharges grass and allows tractor speeds up to 6 M.P.H.
- Computer balanced vibration free rotor turns at 2,000 R.P.M.
- 6" Diameter, full width gauge roller with external bearings
- The lubrication points are external and therefore easy to reach
- Low profile design allows for operating where there are low hanging limbs
- Front protection with metal flaps and chains

MODEL #	MOWING WIDTH	OVERALL WIDTH	MAX OFFSET	NO. OF KNIVES	MAX. OFFSET FROM TRACTOR CENTERLINE	MIN. H.P. REQUIRED	WT.
S7C-175	69"	75"	29"	18	62"	50 H.P.	1,215#
S7C-200	79"	85"	29"	21	72"	60 H.P.	1,325#
S7C-250	98"	104"	39"	27	98"	80 H.P.	1,590#

FLAIL SHREDDERS

"GHF-FS" Series
Fine shred of orchard brush

**"GHF90-FS"
SHOWN**



**Hammer
Knives**

Built by :



The **GHF-FS Series** was developed for fine shredding of orchard brush. These shredders feature 4 internal re-cutter bars to reduce the brush until it is finely shredded. The rake teeth keep the material inside the mower hood to reach a consistency of decomposable mulch. The large 10 inch diameter rotor is mounted with drop forged hammer knives giving optimum shredding performance. These shredders are specially designed for severe conditions of orchard brush, but can also be used in weed abatements, tall grasses, heavy weeds, and cover crops.

FEATURES:

- Fits Cat. II 3-point, center mount
- Available for tractors with 540 or 1,000 R.P.M.,PTO
- Front or rear tractor mount
- Shreds brush or prunings up to 3", intermittent 4"
- Gearbox H.P. of 200, with built-in overrunning clutch
- Specially designed drop forged hammer knives give optimum performance in brush shredding, mulching pruning & grass cutting
- 10" diameter, computer balanced rotor
- Four rows of drop forged cutter bars to increase the shredding of material
- Equipped with large number of rear mounted rake teeth
- 10" diameter, computer balanced, vibration free rotor turns a 2,000 R.P.M.
- Drop forged hammer knives give optimum performance in brush shredding
- 8" diameter, full width gauge roller with bearings
- Hood plate ¼" thick, double plated front and back side plates ½" thick
- Double row of front safety chains

NOTE: If fine shredding is not required, order rubber rear hatch and no rakes at no additional charge

MODEL #	MOWING WIDTH	OVERALL WIDTH	NO. OF KNIVES	NO. OF RAKES	MIN. H.P. REQUIRED	WT.
GHF90-FS	7' - 9" (89")	8' (96")	24	18	90 H.P.	2,670#
GHF100-FS	8' - 2" (98")	9' (108")	26	20	100 H.P.	2,800#
GHF120-FS	9' - 10" (118")	10' - 6" (126")	30	24	120 H.P.	3,130#
GHF140-FS	11' - 6" (138")	12' - 2" (146")	36	28	140 H.P.	3,530#

**"S9C-225"
SHOWN**

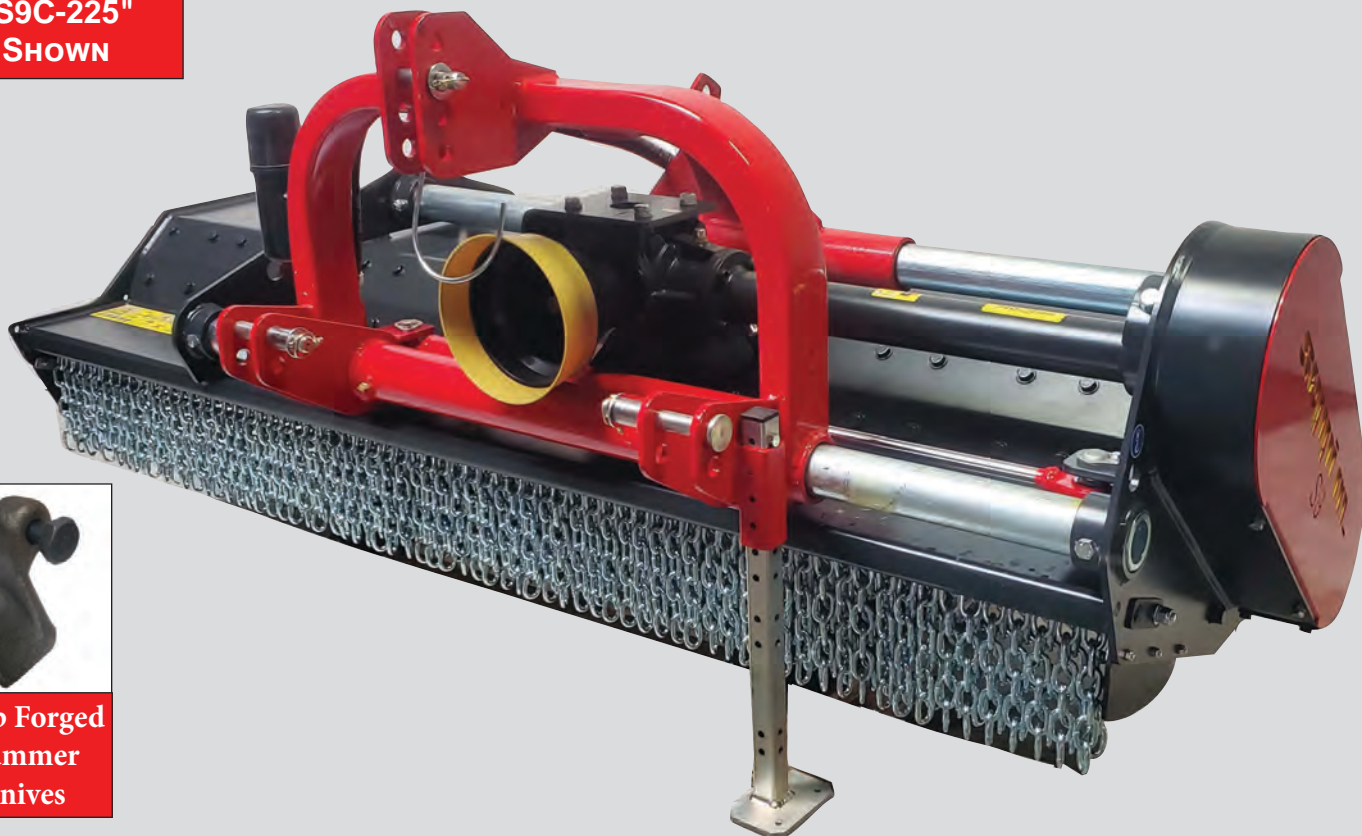

**Drop Forged
Hammer
Knives**

This **Flail Shredder** has a unique hydraulic side shift system that moves horizontally on front and rear mounted heavy steel tubes. These units were designed for high usage with limited maintenance. This is achieved by a number of special features such as - high tensile steel hood, internal hood replaceable "Hardox" wear plates, replaceable drop forged re-cutter bars and large 150 horsepower gearbox. The adjustable rear hatch can be closed for maximum shredding or open for maximum speed up to 6 MPH.

S9C FEATURES:

- Cat. II, 540 R.P.M. hydraulic offset
- 150 H.P. gearbox with overrunning clutch
- Hydraulic offset - 28 inches
- Mulches grass and prunings up to 3 1/2"
- Working speeds up to 6 miles per hour
- Drop forged hammer knives
- Hood assembly made of high tensile steel
- Replaceable drop forged re-cutter bars to increase material shredding
- Adjustable rear hatch - closed for maximum shredding, open for maximum speed
- Rotor bearings are double self-aligning
- Large 7.6" diameter adjustable rear roller
- Front mounted double row of safety chains and rear mounted rubber guards

OPTION:

~ 1,000 R.P.M. gearbox

Built by :



MODEL #	S9C-200	S9C-225	S9C-250
Shredding Width:	79" (6'-7")	89" (7'-5")	98" (8'-2")
Overall Width:	85" (7'-1")	95" (7'-11")	104" (8'-8")
Max. Offset F/C:	67.5"	72.5"	77.5"
No. of Knives:	21	24	27
Min. H.P. Req'd:	75 H.P.	80 H.P.	85 H.P.
Weight:	1,940#	2,120#	2,260#

ORCHARD BRUSH PROCESSOR

One Pass
Processing into fine mulch

FEATURES:

- For tractors up to 200 H.P.
- Cat. II, 3-pt. hitch, 1,000 R.P.M. PTO driven
- Processes brush up to 4" in diameter into a fine decomposable mulch
- 3-Tipped tungsten carbide fixed knives
- Two pick-up feed rotors with pressure gauge
- 6 Rows of drop forged fixed, carbide tipped re-cutter bars
- Dual 5 belt rotor drive
- Heavy ½" (12 mm) thick plate screen with diamond shaped holes for final processing
- Dual rear wheels with manual height adjustment
- Reinforced body made of high tensile S420 steel
- Two adjustable parking stands
- Recommended tractor speed from 1 to 2 M.P.H.



Wrap Around Rotor
Blade Holder &
Tungsten Carbide Tips

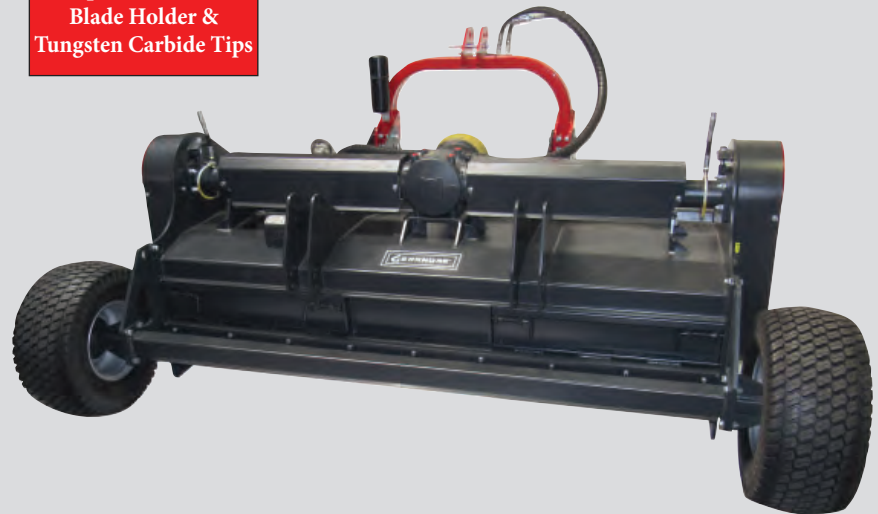

Built by :



The Gearmore 3-point hitch, PTO driven, self-feeding **Brush Processor** was designed to shred material up to 4" in diameter into a very fine mulch that will decompose in the rows without affecting your harvesting operations. The brush is fed through two hydraulic driven pick-up feed rotors into the processing chamber. The large 20" diameter rotor with fixed triple tipped tungsten carbide knives shreds the brush against six rows of drop forged re-cutter bars into finer material. This mulch is then forced through a fine mesh heavy steel screen. To complete the finishing operation we recommend the Gearmore Orchard Tiller with rear roller to bury the fine mulch 2 to 3 inches deep.

MODEL #	WORK WIDTH	TOTAL WIDTH	TOTAL DEPTH	TOTAL HEIGHT	NO. OF KNIVES	WT.
WBS225-3PT	89"	115"	80"	58"	36	5,130#

NOTE: This unit is also available in front mount & rear 3 pt. push version



These forestry **Mulchers** are suitable for forest work as well as the most demanding applications in landscaping and maintaining areas in which prunings, stumps, and wood that must be eliminated. Mulchers have a heavy mounting receiver plate for skid steer/track loaders. The powerful hydraulic system on the MINIFORST is compatible with track loaders flow rates of 20 to 45 gallons per minute. The powerful efficient hydraulic M-BOOST™ motor, delivers 40% more torque than standard motors.

FEATURES:

- Mounts to standard Skid Steer mounting bracket
- Mulches wood up to 8 inches (20 cm)
- Operating speed up to 3 miles per hour (5km/h)
- Variable displacement hydraulic motor with relief valve
- Required hydraulic flow – 20 to 45 gallons per minute
- Hood made of S420 high tensile steel
- Replaceable side skids for added depth control
- Units available less hood
- Hydraulic pressure 2,175 to 5,000 PSI
- Fixed rotor hammers with dual tungsten carbide tipped tools or cut control mini blades
- Five rows of heat treated re-cutter bars for finer mulch
- Hydraulically operated front hood when closed produces finer mulch
- “Patented” blade holder, wraps around rotor drum for added strength
- Rear safety chain protection
- Hydraulic hoses included
- Impact resistant screen required

Built by :



NOTE: Available for 3-pt. hitch mounted tractors, PTO driven

MODEL #	WORK WIDTH	OVERALL WIDTH	DEPTH	NO. OF BLADES	WT.
CL150	59"	71"	39"	30	2,325#
CL175	69"	81"	39"	33	2,515#
CL200	79"	91"	39"	36	2,790#

FLAIL/MOWER SHREDDERS

Hydraulic Driven
SSL mount medium & heavy duty models

This **Mower/Shredder Series** delivers excellent cutting, mulching and mowing action for material up to 2" in diameter. The special floating linkage allows the mower/shredder to follow the terrain for even cut. For use in vineyards, berries and other narrow applications. Also, used for roadsides, parks, rental yards, and weed abatement.

FEATURES:

- Shreds brush or prunings up to 2"
- Cutting height adjusts from 1" to 4"
- Unique floating hitch allows shredders to follow the contour of the ground
- Equipped with rear deflector which in open position discharges grass and in closed position contains and further shreds brush to a finer mulch
- Variable displacement piston motor with relief valve
- Swing Y blades or hammer knives
- Deck made of high tensile steel S420
- Front guards provide safety from flying material
- Comes complete with hydraulic hoses, quick couplers, and case drain line
- For track loaders 16 to 39 G.P.M. and 2,175 to 3,265 PSI
- Impact resistant windshield required

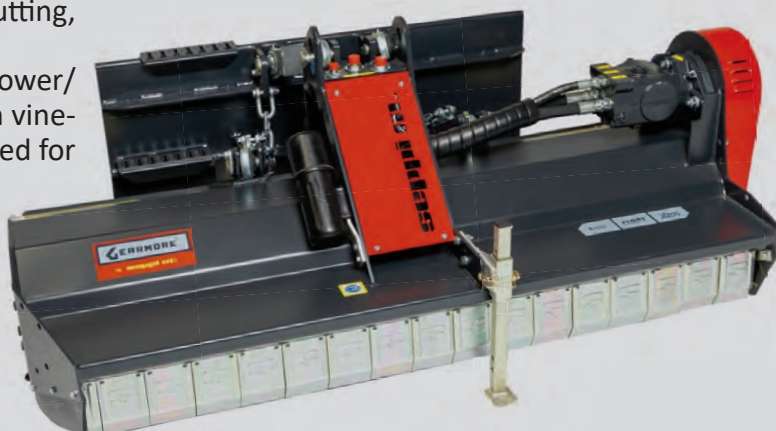

MODEL #	MOW WIDTH	TOTAL WIDTH	NO. OF BLADES	NO. OF HAMMERS	G.P.M. REQ'D	WT.
SMWA155-HS	5'-1" (61")	5'-6" (66")	54	15	16 to 39	980#
SMWA175-HS	5'-9" (69")	6'-2" (74")	66	18	16 to 39	1,095#

The **SMO Mower/Shredder** is a heavy duty model. This unit is excellent for cutting, mulching and mowing of material up to 3 inch material. The SMO comes standard with hammer knives. The special floating linkage allows the shredder to follow the terrain for even cut. Designed for operating in heavy brush.

HD MOWER/SHREDDER

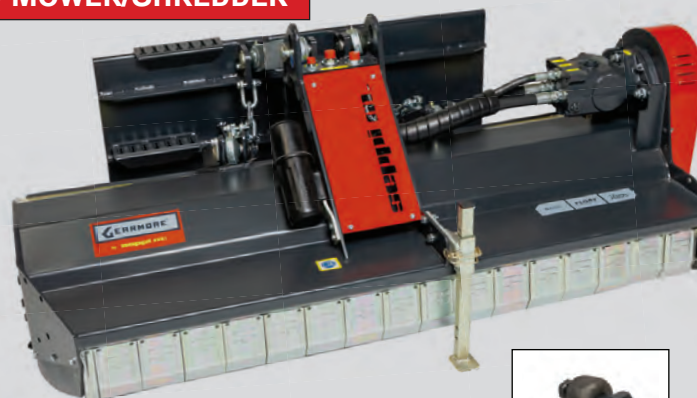

FEATURES:

- Shreds brush or prunings up to 3"
- SSL quick attach mount
- Cutting height adjusts from 1" to 4"
- Unique floating hitch allows the shredder to follow the contour of the ground
- Variable displacement piston motor with relief valve
- Heavy duty hammer knives
- Two rows of heat treated re-cutter bars
- Equipped with rear deflector, open for grasses, closed for brush
- Deck made of high tensile steel S420
- Front guards provide safety from flying material
- Comes complete with hydraulic hoses, quick couplers, and case drain line
- For track loaders 16 to 39 G.P.M. and 2,175 to 3,265 PSI
- Impact resistant windshield required



**Hammer
Knives**

NOTE: The model SMO is the same design as the SMWA Shredders but heavier, wider and more capacity

MODEL #	MOWING WIDTH	TOTAL WIDTH	NUMBER OF HAMMERS	G.P.M. REQ'D	WT.
SMO200-HS	6'-7" (79")	7'-1" (85")	21	16 to 39	1,510#

Built by :

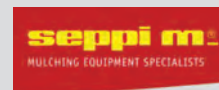



Certain crops produce very high quantities of prunings. This can cause big problems when it is time to mulch them. Burning is often illegal and is always bad for the environment. The **Pick-Up Mulcher** provides a perfect solution. Picking up the prunings with a pick-up rotor at ground level and hydraulic adjustable upper feed rotor. The prunings are then shredded within a hood to produce a fine and uniform mulch. This results in a fast bio degradation, just one cultivation cycle. The Pick-Up Mulcher is particularly suitable for orchards, vineyards and many other applications. Mulches wood up to 8" and occasionally larger diameters.

FEATURES:

- Mulches wood up to 20 cm (8") and occasionally larger diameters
- Chassis and radial rotor sections made of wear resistant steel AR400
- SAE skid steer attachment interface
- Variable displacement motor 24 - 42 G.P.M. with relief valve, 150 - 300 bar, 2,175 - 4,350 PSI
- 2 large gauges readable from the track loader. One for shredding rotor pressure, one for the pick-up rotor pressure
- Two pick-up rotors, each rotor with motor and hydraulic system
- 4 rows of replaceable tempered counter cutters
- 4 rubber gauge wheels, adjustable in height
- Upper feed roller and hood assembly with hydraulic cylinder; closed creates optional crushing, open when high piles of wood occur
- Cab mounted two lever control box; one for forward and reverse of the feed rotors and one for adjusting the opening and closing of the upper feed rotor hood assembly
- Unique cutting rotor with stacked plates to limit the cut for continuous operation
- Helical RIC "Patent" rotor with super mono tip hammers with tungsten carbide tips
- Impact resistant windshield required

MODEL #	WORKING WIDTH	OVERALL WIDTH	OVERALL HEIGHT	NO. OF HAMMERS	WT.
Miniforst Pick-Up CL 175	69"	88"	99"	33	3,600#

MINIFORST PICK-UP

3-Point Hitch
PTO driven, single or dual drive



MINIFORST PICK-UP



MINIFORST PICK-UP DT

Certain crops produce very high quantities of prunings. This can cause big problems when it is time to mulch them. Burning is often illegal and is always bad for the environment. The **Pick-Up Mulcher** provides a perfect solution - picking up the prunings with a pick-up rotor at ground level and adjustable upper feed rotor. The prunings are then shredded within a hood to produce a fine and uniform mulch. This results in a fast bio degradation, in just one cultivation cycle. The Pick-Up Mulcher is particularly suitable for orchards, vineyards and many other applications. Mulches wood up to 8" and occasionally larger diameters.

FEATURES:

- Mulches wood up to 20cm (8) inches in diameter
- Gearbox maximum horsepower 120 or 240
- Single or dual final drive for added power
- Heavy Cat. II, 3-point hitch
- Hydraulic hood with single or dual hydraulic cylinders, closed creates optimal crushing conditions, open when high piles of wood occurs
- Gearbox 1,000 R.P.M. with overrunning clutch
- Unique cutting rotor with stacked plates to limit the cut for continuous operation
- Helical RIC "Patent" rotor with super mono tip hammers with tungsten carbide tip
- Chassis and radial rotor sections made of wear resistant steel AR400
- Rotor driven by tractor hydraulics require flow of 5.3 G.P.M.
- Hydraulic hood with pick-up rotor includes motor and hydraulics system with flow control
- Lower pick-up rotor including motor and hydraulic system
- Support rotor, adjustable in height
- Rubber gauge wheels
- 4 Rows of heat treated replaceable re-cutter bars

NOTE: *If your tractor does not have a front 3-point hitch and PTO, you will have to operate the Miniforst in reverse.*

MODEL #	WORKING WIDTH	OVERALL WIDTH	MAX. HORSEPOWER	NO. OF HAMMERS	WT.
Miniforst Pick-Up 175	69"	99"	120	33	3,220#
Miniforst Pick-Up 200	79"	109"	120	39	3,620#
Miniforst Pick-Up DT 225	89"	111"	240	45	4,300#

Built by :



3 Series

Compact, standard duty & heavy duty

ROTARY MOWERS

COMPACT ROTARY MOWER



**MDL.
L-48-40-XB**

Our *Rotary Mower* was developed to obtain maximum strength and stability. The strength was obtained by using the same gearbox, spindle assembly, blades and driveshaft that are used on our larger mowers. The stability was obtained by mounting the mower closer to the tractor with the addition of twin rubber tailwheels. This combination of strength and stability allows the operator to mow in rough terrain with maximum control of the tractor and mower.

- Cat. I, 3-point hitch
- Adj. cutting heights 1" - 6"
- Bolt-on replaceable side plates
- Adj. dual rubber tailwheels
- Std. front rubber shielding

MODEL #	CUT. WIDTH	OVERALL WIDTH	OVERALL DEPTH	WT.
L-48-40-XB	48"	51"	62"	400#

STANDARD DUTY

Our *200 Series Mowers* feature round back design for easy maneuvering in tight corners, around trees, fences, and other obstructions. The flexible floating hitch follows the contour of the terrain without putting stress on the mower and tractor.

- Hitch: Cat. I, ASAE Q.H.
- Gearbox: 540 R.P.M.
- Deck Depth: 7 1/2"
- Tailwheel: 3 3/4"x15" Laminated
- Cut Height: 1" to 9"
- Driveshaft: Shear Pin or Slip Clutch

- Blade size - 1/2" x 3"
- Fully welded deck
- Cuts up to 1" dia. material
- Shielded series 4 PTO shaft
- Safety chains front & rear



Cat. I
A.S.A.E.
Quick Hitch
Compatible

60" MOWER SHOWN

MODEL #	CUT. WIDTH	GEARBOX H.P.	OVERALL WIDTH	OVERALL LENGTH	BLADE TIP SPEED - FPM	WT.
RC200-48	48"	40 H.P.	52"	85"	13,090 FPM	550#
RC200-60	60"	40 H.P.	63"	98"	14,335 FPM	640#
RC200-72	72"	40 H.P.	76"	110"	14,955 FPM	765#

HEAVY DUTY



L72-60HD SHOWN

These *Gearmore Mowers* are the economical answer for medium duty use in weed and brush mowing. Special built-in features include floating hitch that follows the contour of the terrain, heavy round spindle pan to protect the gearbox, strong 8" I beam side channels for added strength.

- Floating hitch design follows contour of terrain
- Heavy 8" I beam sides w/ribbed crossmembers
- Slip clutch driveshaft to prevent damage
- Safety chains front & rear
- Side Rails:* 8" I Beams
- Top Deck:* 3/16" Plate
- Hitch:* Cat. II
- Gearbox R.P.M.:* 540
- Tailwheels:* Laminated
- Blade Holder:* Spindle Pan
- Driveshaft:* Slip Clutch

MODEL #	CUT. WIDTH	OVERALL WIDTH	OVERALL LENGTH	TAIL WHEELS	GEARBOX H.P.	WT.
L72-60-HD	72"	74"	92"	2	60 H.P.	1,185#
L84-80-HD	84"	86"	104"	2	80 H.P.	1,570#



WARNING: If operating mower near roads and/or where people are present, you must equip mower with deck shielding

VACUUM PLANTERS

For the precision
seeding of vegetable seeds



We custom build planting systems to growers individual requirements, see our website for details.

The **Gearmore Precision Vacuum Planters** are designed for extremely accurate vegetable seed placement. The PTO driven turbine fan or optional hydraulic drive creates a vacuum that draws seeds against the seed plates. Inner and outer singulators remove doubles to insure that individual seeds are secured to the vacuum hole. At the seed release point, vacuum is cut off and the seed is deposited in the furrow. The air compressor then injects a short blast of air to insure the hole is clean for the next seed. Easy to operate and maintain, this durable precision planter efficiently handles the smallest of seeds either raw or coated.

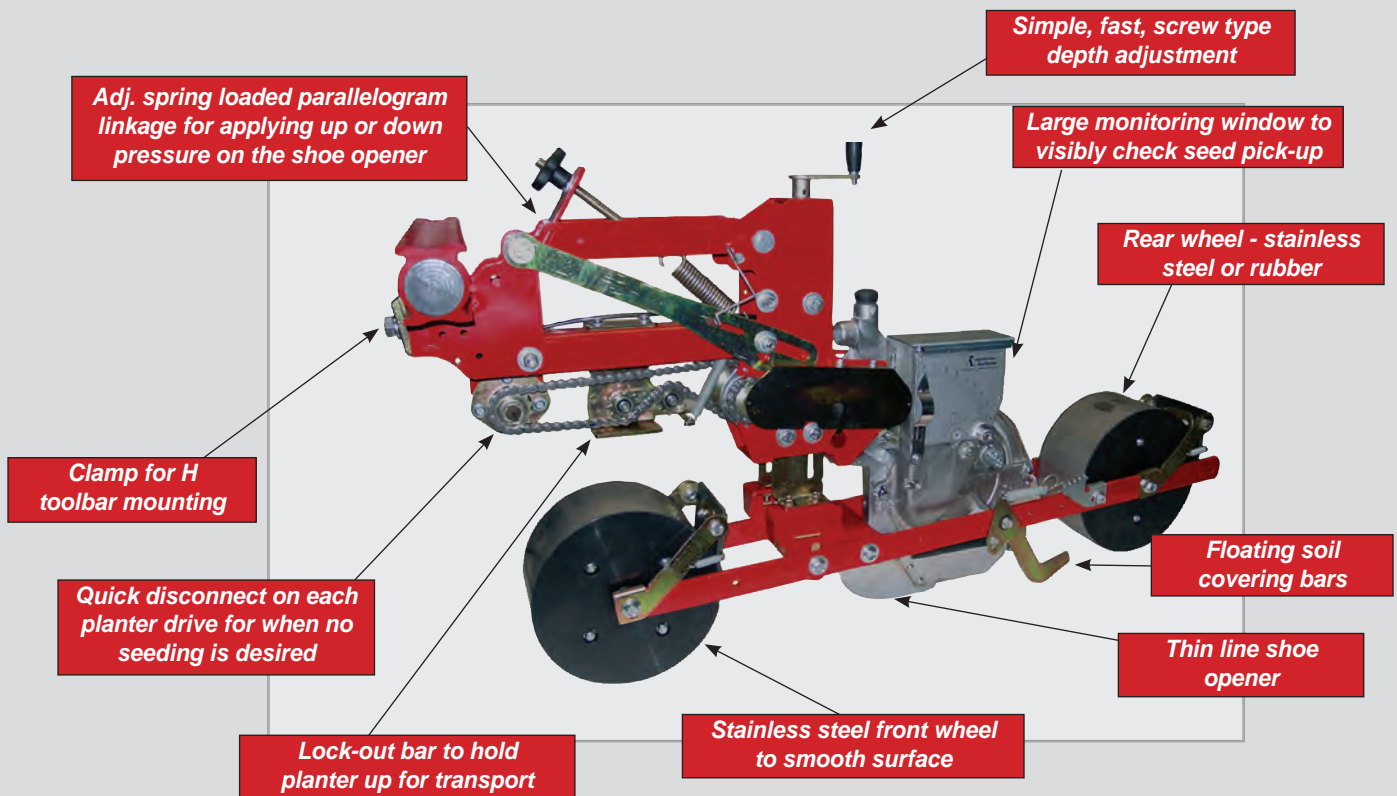

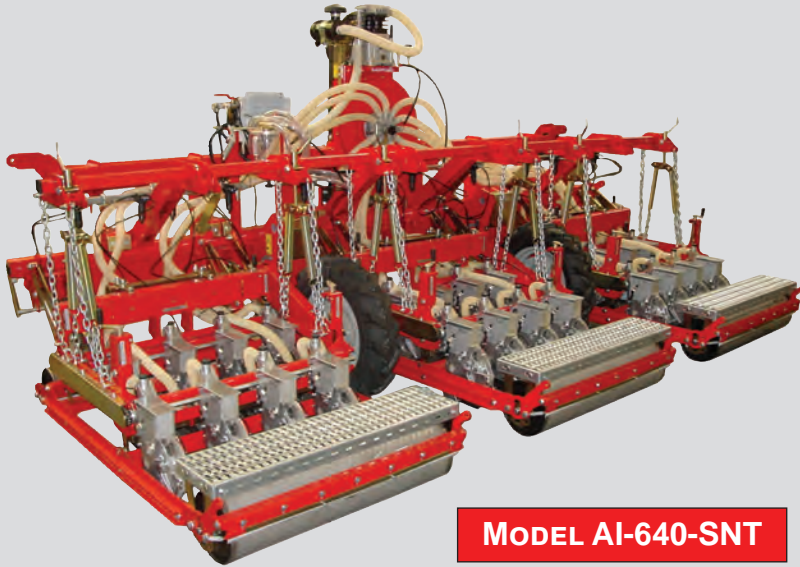

MODEL AI-640-SNT

The *Gearmore Precision Vacuum Planters* are designed for extremely accurate vegetable seed placement. The PTO driven turbine fan or optional hydraulic drive creates a vacuum that draws seeds against the seed plates. Inner and outer singulators remove doubles to insure that individual seeds are secured to the vacuum hole. At the seed release point, vacuum is cut off and the seed is deposited in the furrow. The air compressor then injects a short blast of air to insure the hole is clean for the next seed. Easy to operate and maintain, this durable precision planter efficiently handles the smallest of seeds either raw or coated.

MODEL #	DESCRIPTION	WIDTH	DEPTH	WT.
AI-640-SNT-2	Vacuum Planter	20'	8'	4,500#

FOLDING PLANTERS for 3 - 80" or 3 - 88" rows

HOW METERING SYSTEM OPERATES

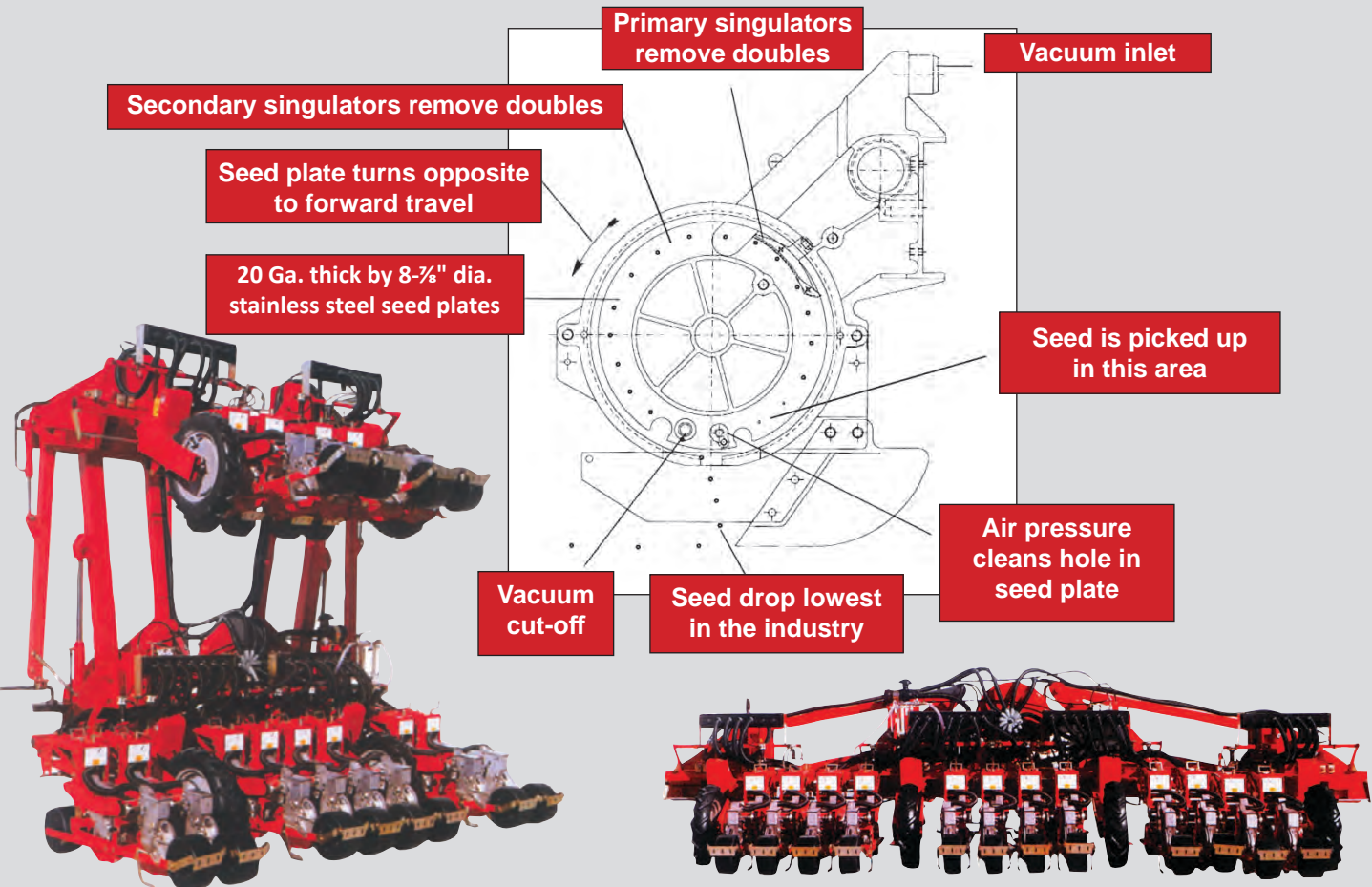

We design and assemble planters to your specifications

RAKES & RIDGERS

These **Landscape Rakes** are ideal for general grooming, soil preparation, removing rocks, roots and debris, and spreading crushed rock or top soil. Five forward and reverse angle positions for windrowing material. The reverse positions are great for pushing material into low spots. We have three widths of rakes available for tractors 30 to 60 horsepower.



Optional Dual Caster Gauge Wheels

Features for LRU Series:

- Cat. I, A.S.A.E. quick hitch compatible
- For tractors up to 60 H.P.
- 5/16" x 1" x 15" High carbon steel teeth
- 1" Spacing between teeth
- Five forward and reverse angle settings
- Frame is made of 3/16" x 4" x 4" steel tubing

Optional equipment:

- ~ Dual caster gauge wheels
- ~ Teeth stiffeners

**MODEL LRU-7
RAKE SHOWN**



Cat. I
A.S.A.E.
Quick Hitch
Compatible

MODEL #	WIDTH	HORSEPOWER	NO. OF TEETH	WT.
LRU-6	72"	30 to 60 H.P.	36	240#
LRU-7	84"	30 to 60 H.P.	42	270#
LRU-8	96"	30 to 60 H.P.	48	300#

RIDGERS

Adjustable gangs, built for heavy duty use

FEATURES:

- Cat. II, 3-point A.S.A.E. quick hitch
- 4" x 6" x 1/4" Wall x 8' long toolbar
- Gangs adjust for tilt and pitch
- Self aligning 1 1/2" trunnion bearings
- Available in 3 or 4 blade
- Blades on 9" centers with cast iron spacers
- Parking stand
- Optional mud scrapers
- Available with blockers



CAT II
A. S. A. E.
QUICK
HITCH
COMPATIBLE

MODEL #	DESCRIPTION	REQUIRED HORSEPOWER	WT.
BE222-3	3 Blade Ridger with 22", 24", & 26" Blades	60 Minimum H.P.	1,000#
BE422-4	4 Blade Ridger with 22", 24", 26", & 28" Blades	60 Minimum H.P.	1,080#



The **GR100** is for tractors up to 25 H.P. These rippers are great for cutting narrow trenches for irrigation pipe. The optional 15" furrower shovel digs a smooth trench for water flow.

The **GR200** is for tractors up to 50 H.P. This unit is recommended for breaking up compacted soil to increase root growth and yields.

The **GR300** is for tractors up to 75 H.P. and was designed for heavier duty use. Thus, the ripper can be used for high horsepower tractors. This ripper is recommended when deep ripping is required.

MODEL #	H.P. RATING	FRAME TUBE SIZE	SHANK LENGTH	SHANK SIZE	HITCH	SHEAR BOLT PROTECTION	OPTIONAL 12" FURROWER	PARKING STANDS	WT.
GR100	Up to 25	3" x 3"	19"	1" x 4"	Cat. I	Yes	Yes	No	85#
GR200 *	Up to 50	4" x 4"	22"	1" x 6"	Cat. I	Yes	No	Standard	100#
GR300 *	Up to 75	4" x 8"	27"	1" x 10"	Cat. II	Yes	No	Standard	240#

* Also available with hard faced shanks and points.

TIRE TRACK RIPPER

Breaks up "hard pan" created by tractor tires



Tractors have to make many passes through vineyards and orchards. This creates hard pan under the tractor tires. From time to time, it is recommended to rip that area to aerate the soil for better water penetration to increase root growth. The spread width of the ripping shanks can be set to the tractor tire centers and this then shatters the soil over the compacted area up to 18" deep. These rippers have two 4" x 6" beams for added strength. Models available for all popular vineyard row spacings.

FEATURES:

- Cat. I & II, 3-point, ASAE quick hitch
- 2 - Adj. shanks for ripping soil up to 18" deep
- Adj. bolt-on shank brackets can be set for different tractor tire tread widths
- Shear bolt design, shanks swing up if hitting obstructions

MODEL #	DESCRIPTION	FOR ROW WIDTHS	BEAM	ADJ. SHANK CENTERS	WT.
R2-55	3-Pt. Ripper	6' (72")	55"	38" to 48"	320#
R2-67	3-Pt. Ripper	7' (84")	67"	40" to 60"	350#
R2-72	3-Pt. Ripper	8' (96")	72"	48" to 66"	360#
R2-96	3-Pt. Ripper	10' (120")	96"	60" to 90"	390#

- Shanks are made of 1" x 6 1/2" x 22" steel
- Main beam 4" x 6" x 1/4" wall tubing
- Replaceable high carbon, heat treated points
- Clevis type hitch bracket
- Parking stand

OPTION:

- ~ Hard faced shanks & points

V-RIPPERS

3 Series
For tractors 30 to 175 H.P.

These *V-Rippers* come in narrow widths for vineyards and berries and wider widths for general farm use. The "V" design main beam and curved shanks reduce horsepower requirements. The deep ripping obtains excellent soil aeration, which allows greater water penetration and absorption. Also increases root growth.

MODEL #	NO. OF SHANKS	BEAM WIDTH	WT.
R3-50	3	50"	420#
R3-60	3	60"	435#
R3-70	3	70"	450#
R5-60	5	60"	550#
R5-70	5	70"	570#



FEATURES:

- Cat. I, 3-point hitch
- 4" x 6" main beam
- 1" thick x 22" long shanks
- Shanks adjustable with shear pin protection

FEATURES:

- Cat. I & II, 3-point hitch
- 4" x 6" main beam
- Shear bolt protection
- 1" thick x 27" long shanks
- Shanks adjustable with shear pin protection

MODEL #	NO. OF SHANKS	BEAM WIDTH	WT.
VR3	3	84"	750#
*VR3-HF	3	84"	760#
*includes hard faced shanks & points			



FEATURES:

- Cat. II & III, 3-point hitch
- 3/8" x 6" x 8" main beam
- Shanks are 1 1/4" thick x 31" long
- Shanks are adjustable with shear pin protection
- Maximum H.P. 175

NEW

MODEL #	NO. OF SHANKS	BEAM WIDTH	WT.
RS-30HD	3	5' - 3"	1,100#
RS-50HD	5	8' - 2"	1,700#
RS-70HD	7	13' - 8"	2,300#



BOX SCRAPERS & TOP & TILT

Cat. I
A.S.A.E.
Quick Hitch
Compatible

"BSL" Series



- For compact tractors up to 30 H.P.
- Clevis type hitch brackets
- Side plates are ¼" x 16" x 22"
- Main beam ¼" x 4" x 4" tubing
- Heat treated scarifier shanks w/replaceable points, four position

MODEL #	CUT WIDTH	NO. OF SHANKS	WT.
BSL-42	42"	3	275#
BSL-48	48"	4	290#

"BB" Series



- For tractors up to 40 H.P.
- Main beam - ¼" x 4" x 4" tubing
- Heat treated shanks with replaceable points
- 2 Depth settings on scarifier shanks
- Side plates are ¼" x 16" x 24"

MODEL #	WIDTH	NO. OF SHANKS	WT.
BB-48	48"	4	315#
BB-54	54"	4	350#
BB-60	60"	5	365#
BB-66	66"	5	390#
BB-72	72"	5	400#

Cat. I
A.S.A.E.
Quick Hitch
Compatible

Standard color is black - most tractor colors available at no additional charge

TOP & TILT KITS

Valve/bracket assembly and cylinders



Valve & Bracket Assembly

To make box scrapers more versatile, nothing works better than being able to control the tilt and pitch of the implement. Grading jobs are more accurate because you have complete control to develop the slopes you require when landscaping, building roads, etc.

Valve & Bracket Assemblies

- Valves are available in 1, 2, 3 & 4 spool
- Valves handle flows from 15 to 17 G.P.M. (10-13 G.P.M. through the ports) @ 3,000 PSI
- Brackets available for most popular models
- Bracket assemblies consist of: rollbar clamp, adjustable arm with valve mounting and safety valve cover



Top & Tilt Cylinders

Cylinders

- Special built-in oil flow restrictors which insure smooth operation
- Specially designed to fit your tractor
- Cylinders available in 2", 2 ½" & 3" bore, depending on the tractor size

BOX SCRAPERS

"GBS" & "2G2M" Series Manual or hydraulic shank retracting

FEATURES:

- For tractors 20 to 45 horsepower
- Cat. I, A.S.A.E. quick hitch
- Adjustable heat-treated scarifier shanks with replaceable points, four position
- Reversible ½" x 6" cutting edges, front and rear
- A-frame mast - ½" thick x 6" wide
- Hydraulic option
- Standard color is black - most tractor colors are available at no additional charge

Our **Box Scrapers** feature clean modern design with all welded construction for added strength. Thus, no assembly required. Whether you want to landscape, terrace, back-fill, scarify, level, or do general clean-up, the Gearmore Box Scrapers will fit your needs.



CUTTING WIDTH	OVERALL WIDTH	NO. OF SHANKS	WT.	
			GBS	GBS/H
42"	42 ½"	3	330#	NLA
48"	48 ½"	4	355#	405#
54"	54 ½"	4	395#	435#
60"	60 ½"	5	440#	480#
66"	66 ½"	5	490#	505#
72"	72 ¾"	6	540#	575#
84"	84 ¾"	7	620#	NLA

FEATURES:

- Cat. I, ASAE Quick hitch
- For tractors up to 60 horsepower
- All welded construction
- Heavy duty ½" thick shank pockets
- Double plated rear moldboard - 22" high
- Four position, heat-treated shanks with replaceable points
- Side plates are ⅜" x 22" x 33"

Cat. I
A.S.A.E.
Quick Hitch
Compatible



MODEL #	WORKING WIDTH	OVERALL WIDTH	NO. OF SHANKS	WT.
2G2M-66	66"	66 ¾"	6	665#
2G2M-72	72"	72 ¾"	6	685#
2G2M-76	76"	76 ¾"	6	705#
2G2M-84	84"	84 ¾"	7	790#

Industrial "2G" & "4G" Series

For tractors 20 to 100 H.P. - hydraulic shanks

BOX SCRAPERS



"2G1" SERIES



"2G2" SERIES

Cat. I
A.S.A.E.
Quick Hitch
Compatible

FEATURES:

- Unique hydraulic scarifier system raises scarifier to high clearance position and lowers beam to working position plus automatically self-locks with heavy hardened pin
- Two position, forged, heat-treated shanks with replaceable points
- 2 ½" x 6" Reversible heat-treated cutting edges, front and rear
- Non-rotating pins or replaceable bushings at all pivot points
- Cat. I clevis lower hitch brackets

Series	2G1 Series				2G2 Series				
Model:	2G1-42	2G1-48	2G1-54	2G1-60	2G2-60	2G2-66	2G2-72	2G2-76	2G2-84
Working Width:	42"	48"	54"	60"	60"	66"	72"	76"	84"
Overall Width:	42 ½"	48 ½"	54 ½"	60 ½"	60 ¾"	66 ¾"	72 ¾"	76 ¾"	84 ¾"
No. of Shanks:	4	4	5	5	5	6	7	7	8
Approx. Weight:	410#	445#	480#	520#	770#	830#	860#	890#	920#
HP Rating:	20 to 40 H.P.				45 to 70 H.P.				

INDUSTRIAL "4G" SERIES

For tractors 50 to 100 horsepower

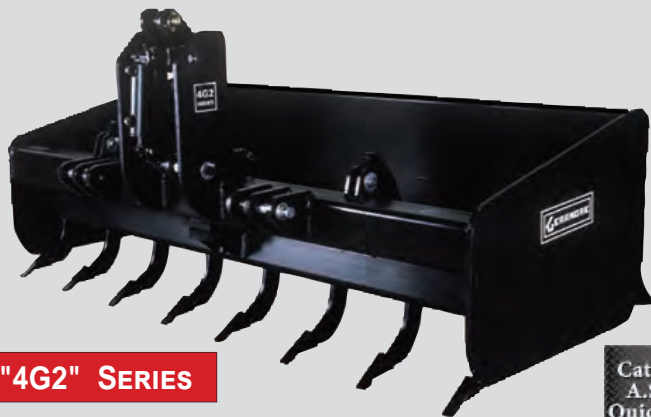

"4G2" SERIES



"4G4" SERIES

Cat. I & II
A.S.A.E.
Quick Hitch
Compatible

- All welded construction
- Floating and fixed tailboard models
- 2 Position, forged, heat-treated shanks with replaceable points
- Main beam ⅜" x 5" x 5" tubing
- Cat. I & II clevis lower hitch brackets
- Non-rotating pins or replaceable bushings at all pivot points

Series	4G2 Series				4G4 Series		
Model:	4G2-72	4G2-76	4G2-80	4G2-84	4G4-80	4G4-84	4G4-88
Working Width:	72"	76"	80"	84"	80"	84"	88"
Overall Width:	73"	77"	81"	85"	81"	85"	89"
Approx. Weight:	1,150#	1,190#	1,220#	1,260#	1,340#	1,400#	1,470#
Side Plates:	½" x 24" x 32"				½" x 24" x 35"		
H.P. Rating:	50 to 80 H.P.				60 to 100 H.P.		

CORRAL SCRAPERS

Corral Scrapers 3-Point hitch and pull type scrapers

MODEL #	WIDTH OF CUT	CAPACITY	WT.
CS72	72"	36 cu. ft.	660#
CS84	84"	42 cu. ft.	700#
CS96	96"	48 cu. ft.	740#
CS120	120"	60 cu. ft.	800#

½" x 6" Single reversible high-carbon cutting edge

"CS" SERIES

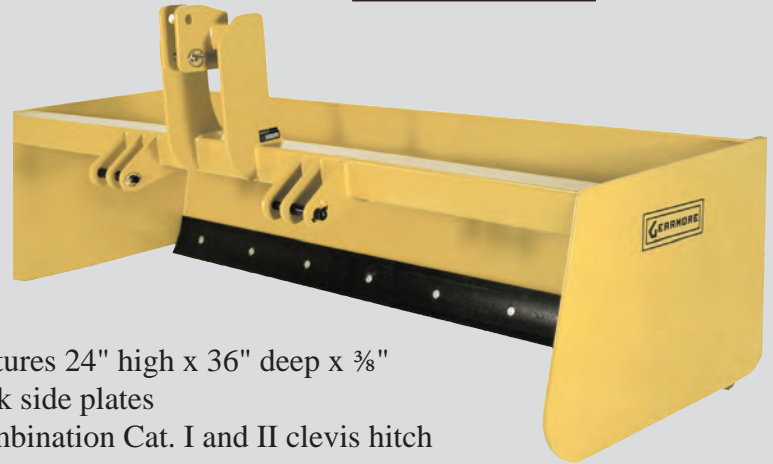

FEATURES:

- Designed to move a lot of material fast
- Square tube main beam 4" x 4" x ¼"
- Rear moldboard ¼" thick
- Heavy duty, large capacity, all welded construction
- Features 24" high x 36" deep x ⅜" thick side plates
- Combination Cat. I and II clevis hitch
- Stepped, non-turning, combination Cat. I & II lower link pins

DRAG SCRAPERS

Compact drag scrapers - pull type

FEATURES:

- Extremely versatile-countless jobs can be done all year round. Level ditches, clean sheds and pens, repair roads, spread gravel, general earth-moving
- Hydraulically operated and controlled from your tractor seat
- Now with removable tongue
- Highly maneuverable
- Cutting edges are ½" x 6" high carbon and reversible
- Scrapers come standard with tires, cylinder, and hoses
- Clevis type hitch

OPTION:

~ Tilt axle assembly



"CD" SERIES

SPECIFICATIONS:	
Working Width:	5, 6, and 7 Foot
Moldboard:	¼" x 18"
Side Plates:	⅜" x 18" x 24"
Tongue:	Removable ⅜" x 3" x 3"
Tires:	Equipped with (2) 5.70-8 Tires
Hydraulics:	2" x 6" Double acting cylinder & hoses
Clearance:	Raised: 12" - Cuts: 3" Below grade
Approx. H.P.:	25 to 50 Horsepower
Capacity:	(5') - ⅞ cu. yd., (6') - 1½ cu. yd., (7') ⅝ cu. yd.
Weight:	(5') - 500#, (6') - 550#, (7') - 600#

All Purpose Series

Easy way to carry, grade and spread material

DRAG SCRAPERS

MODEL AP10 SHOWN

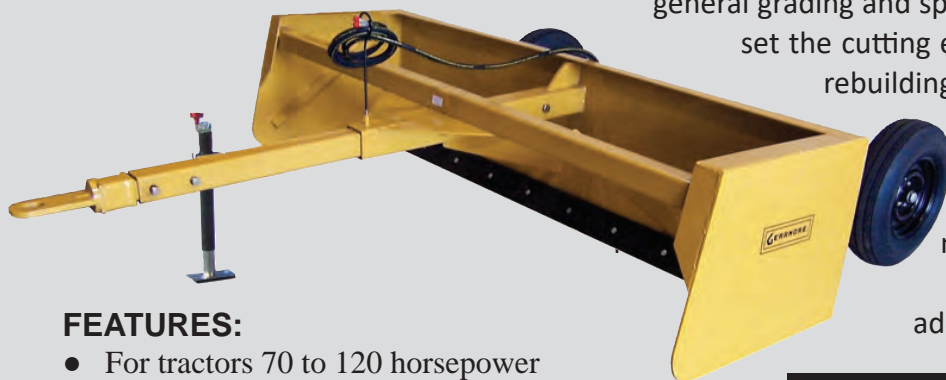

Our *Drag Scrapers* are an excellent implement for carrying and spreading all types of material. Landscapers find the scrapers great for general grading and spreading exact depths of top soil. Contractors set the cutting edge to spread different depths of gravel for rebuilding roads and storage yards. Dairy men find the scrapers best for moving manure. The Drag Scrapers feature a removable 4" x 4" beam tongue that extends to the rear moldboard and is held in place by a 5" x 5" heavy gusseted tube. This feature gives added strength at the point of the most stress.

FEATURES:

- For tractors 70 to 120 horsepower
- Working widths of 8, 10, & 12 foot
- 3/8" x 24" x 36" Deep side plate
- Clearance of 23" raised and 5" below grade
- Hydraulically operated from the tractor seat
- Moldboard 1/4" plate, 24" high
- Main cross beam 4" x 4" tubing
- 3" x 8" Double acting cylinder and hoses
- Ribbed implement tires - 9.5L - 15SL
- Bolt-on hitch with swivel ball

MODEL #	WIDTH	CAPACITY	WT.
AP8	8'	1 3/4 cu. yd.	1,360#
AP10	10'	2 1/4 cu. yd.	1,450#
AP12	12'	3 cu. yd.	1,560#

OPTIONS:

- ~ Tilt Axle w/cylinder & hoses
- ~ Dual Wheels
- ~ Bolt-on Weight Boxes

DRAG SCRAPERS

Drag and deposit large amounts of material

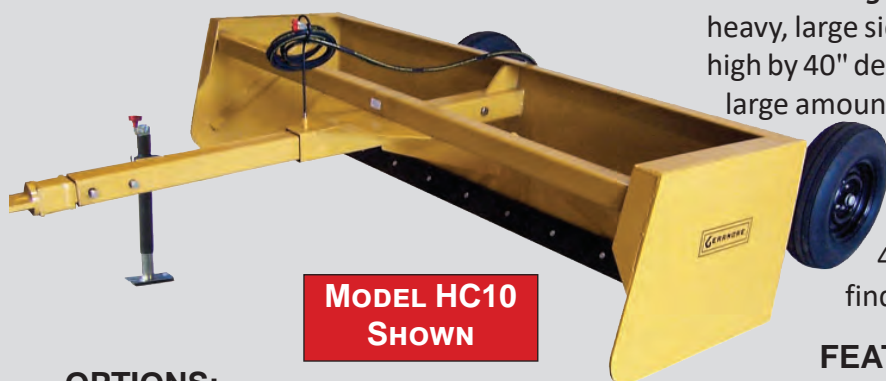

MODEL HC10 SHOWN

The "HC" High Capacity Series of Drag Scrapers feature heavy, large side plates - 1/2" thick. These side plates are 30" high by 40" deep, thus allowing for dragging and depositing large amounts of material. Like the "AP" series, the beam tongue extends to the rear moldboard and is held in place by a 5" x 5" heavy gusseted tube. The new axle assembly is built with 4" x 2" tubing. The larger dairies and feedlots find these scrapers best for their operations.

OPTIONS:

- ~ Tilt Axle w/cylinder & hoses
- ~ Dual Wheels
- ~ Bolt-on Weight Boxes

FEATURES:

- For tractors 70 to 120 horsepower
- Working widths of 8, 10, 12 & 14 foot
- 1/2" x 30" x 40" Deep side plates
- Clearance of 23" raised and 5" below grade
- Hydraulically operated from the tractor seat
- Moldboard 1/4" plate, 30" high
- Internal braces to side plates and moldboard
- Main cross beam 4" x 4" tubing
- 3" x 8" Double acting cylinder and hoses
- Ribbed implement tires - 9.5L x 15
- Bolt-on swivel slotted hitch

MODEL #	WIDTH	CAPACITY	WT.
HC8	8'	2 1/2 cu. yd.	1,450#
HC10	10'	3 1/4 cu. yd.	1,630#
HC12	12'	3 3/4 cu. yd.	1,840#
HC14	14'	4 1/4 cu. yd.	2,050#

NOTE: Tractor colors are available upon request - no charge

GRADING SCRAPERS

Compact, Industrial & Skid Steer Series

Best for repairing and maintaining roads

The **Gearmore Grading Scrapers** were designed to perform many different tasks, such as: landscaping, road repair, arena maintenance, etc. Many unique features enable the operator to do a number of different tasks, no matter what the soil conditions.

General Landscaping - The deep ripping scarifier shanks will break-up the hardest of soils. Dual cutting blade will allow for the movement of large amounts of material when required. To finish grade, set the shanks in the storage position and lightly grade, to finish your landscaping project.

Repairing Roads - The dual blade flow through action cuts out high spots, fills holes and moves material from the edge of the road toward the center, thus achieving a smooth finished road.

FEATURES:

- Quick hitch compatible
- For tractors from 20 to 80 H.P.
- Heavy steel tubing main front beam
- Heavy steel tubing rear support beam
- Heat treated scarifier shanks with replaceable points
- Shanks adjust to ripping & storage positions
- Two ½" x 6" heat treated reversible beveled cutting edges
- Easy to adjust cutting edges with settings of 1 to 1 ½" below side panels (preset at ¼")
- Formed side panels capture and retain material
- ¼" x 2" Replaceable skid plates on side panels



MODEL #	HITCH TYPE	CUTTING WIDTH	OVERALL WIDTH	MIN. H.P.	MAIN BEAM	WT.
GS4	Cat. I	48"	52"	20 H.P.	3" x 3"	415#
GS5	Cat. I	60"	64"	25 H.P.	3" x 3"	450#
GS6	Cat. I	72"	76"	30 H.P.	3" x 3"	505#
GSI7-SS	Skid Steer	84"	89"	45 H.P.	5" x 5"	820#
GSI7	Cat. I & II	84"	89"	45 H.P.	5" x 5"	830#
GSI8	Cat. II	96"	101"	50 H.P.	5" x 5"	860#
GSI10	Cat. II	120"	125"	70 H.P.	5" x 5"	1,020#
GSI12	Cat. II	144"	149"	80 H.P.	5" x 5"	1,140#

LASER GRADING SCRAPERS

Skid Steer System



FEATURES:

- SSL Quick Attach mounting bracket
- Push pull design pushes and pulls material for fine grading
- Heavy stable platform for fine grading
- Front mounted swivel gauge wheels
- Foam filled tires
- Two cylinders provide cross slope operations
- Two moldboard cutting edges are ½" thick by 6" and reversible
- Side plates have adjustable cutting edges
- Convex mirror allows for material visibility
- Two 1 ½" diameter mast poles
- Grip brackets for easy, safe entry to tractor
- Comes with proportional valve, hoses and fittings

Requirements:

- Auxiliary hydraulic and tractor must be equipped with case drain

Built By:



THREE DIMENSIONAL PRECISION GRADING MADE EASY

The **PD Series** comes ready to produce precise grading by working seamlessly with the on-site horizontal laser reference alongside highly accurate satellite measurements for the vertical reference points. Level Best also comes ready to use with GPS, total stations or sonic technology.

The **Grading Box System** automatically reads the grade and makes adjustments dozens of times per second. This gives the operator far more comfortable working conditions because it's so smooth, and the precision grade is highly accurate to 0.1 of an inch. The result is a new level of operational ease and accuracy for precision grading even for complex contours.

MODEL #	BOX SIZE	BOX CAPACITY		WT.
		Front	Rear	
	Skid Steer Para-Level Grading Box, Double	11.5 cu. ft.	7 cu. ft.	2,020#
PD72	6 Feet	13.4 cu. ft.	8 cu. ft.	2,070#
PD84	7 Feet	15.3 cu. ft.	9 cu. ft.	2,155#
PD96	8 Feet			

STAND-ON GRADING SCRAPERS & GRADER BLADE

NEW

The **PC Series Grading Scrapers** have a unique compact design, making it a perfect solution for grading tasks in confined areas. With laser control you can insure accuracy to .01 inch of specifications. You can navigate tight spaces with ease due to the graders exceptional maneuverability. Now you can do grading projects where larger equipment will not fit.

FEATURES:

- Mini quick hitch mount CII
- Push-pull design for grading in forward and reverse
- Front mounted swivel guage wheels
- Foam filled tires on oscilating axle
- Replaceable cutting edges on front and rear
- Heavy duty cutting edge 1/2" x 6"
- Convex mirror allows for material visibility
- Dual hydraulic cylinder for tilt, right to left
- Comes with two 1 1/2" diameter mast poles
- No daily maintenance - helps to maximize uptime
- Comes with proportional valve, hoses and fittings
- Universal compatibility with all guidance systems



MODEL #	OVERALL WIDTH	FORWARD CAPACITY	REVERSE CAPACITY	WT.
PC-48	48"	4.0 Ft. ³	2.1 Ft. ³	555#
PC-60	60"	4.6 Ft. ³	2.4 Ft. ³	590#

GRADER BLADE

The **Grading Blade** precise grades to within .01" of an inch specifications with laser system. This will let you reduce material overage estimates. You can work in windrows with the ability to adjust the working width of your precision grade. The blade also allows you to cut ditches, slice top soil, crown roads and fields. This extreme duty Grading Blade achieves a smooth operating system and legendary Level Best performance.

FEATURES:

- Heavy SSL quick attach mounting bracket
- Mounts to skid steers and track loaders
- Available with or without laser system
- Reinforced moldboard 20" high by 96" or 108" wide
- Moldboard cutting edge is 3/4" thick by 6" and reversible
- Front mounted flotation gauge wheels, rotate up to +/- 30 degrees
- Blade side shift +/- 13 inches
- Maximum blade tilt with one cylinder up and one cylinder down - 24.5 degrees
- Comes with all hydraulic hoses and JIC couplers



Built by:



Many Laser Mounted Grading Systems Available

MODEL #	DESCRIPTION	GRADING WIDTH	GRADING DEPTH	BLADE LIFT	MACHINE WEIGHT
GB96	Grader Blade	96" (8')	7.43"	6.94"	2,570 lbs.
GB108	Grader Blade	108" (9')	7.43"	6.94"	2,620 lbs.

NEW

"SC" SERIES

The **Compact SC Series Grading Scrapers** fits small compact tractors. These scrapers were developed for operating in small areas that require limited soil mowing. These units require a minimum flow rate of 10 G.P.M. at maximum of 4,000 PSI.

FEATURES:

- Cat. I, 3-point hitch
- Duel rear tires
- 1 ½" x 6" cutting edge
- 1 ½" x 6" diameter mast
- Proportional valve, hoses & couplers
- Optional pull hitch

MODEL #	WIDTH	CAPACITY	TRACTOR WEIGHT	WT.
SC48	48"	4.1 cu. ft.	2,000 - 2,500 lbs.	345#
SC60	60"	5.1 cu. ft.	2,500 - 3,000 lbs.	395#



TD SERIES

The mid-sized **TD Series Grading Scrapers** fit a wide range of wheel tractors and are a popular choice for many contractors. They combine flexibility, and outstanding durability over time in construction applications. The grading boxes are precise grading to .01 of an inch, and have no equal in the market.

FEATURES:

- Cat. I & II, 3-point hitch
- Dual rear tires
- Cutting edges on all 4 sides and are replaceable
- Foam filled tires
- Dual 2 ½" diameter masts
- Proportional valve, hoses and couplers
- Optional Laser System

MODEL #	WIDTH	CAPACITY	TRACTOR WEIGHT	WT.
TD72	72"	17.0 ft³	3,000 - 4,500 lbs.	1,210#
TD84	84"	19.9 ft³	3,500 - 5,300 lbs.	1,305#
TD96	96"	22.8 ft³	4,000 - 6,000 lbs.	1,370#



Built by:



Dozer Blade



- Available in widths of 84" and 96"
- Rated for tractors up to 110 H.P.
- Electro hydraulic controlled angle and tilt
- Heavy moldboard - .31" thick and 28" high
- Replaceable cutting edge and skid shoes

Mulcher

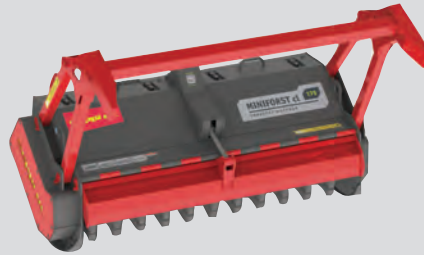

- 59"/69"/79" Cutting width
- Shreds up to 8" diameter trees
- Hydraulic deflector door
- Hammers with carbide tip or cutting blades
- Hydraulic flow of 20 to 45 G.P.M.

QA Grapple Buckets



"Closed Bottom"

- 2 Series of buckets in widths - 60", 66", 72", 76", 82", & 88"
- For machine weights of 8,000 and 12,000 lbs.
- Patented cushioned and sleeved cylinder
- Steel guards to protect cylinders
- Load check valve system

Quick Attach Grapple Brush Buckets



"Skeleton Bottom"

- Widths of 66", 72", 78", 84", & 90"
- For machine weights of 8,000 & 12,000 lbs.
- Patented cushioned & sleeved cylinder
- 100,000 PSI yield strength tine material
- Load check valve system

Quick Attach Low Profile Material Buckets



- Widths - 60", 68", 72", 78" & 84"
- Std. 30" length for more severe conditions when break out force is required
- Long length floor - 36" for better visibility, productivity, & cutting grade
- Strong box sections & full wear strips for better bottom protection
- Designed w/20° rollback angle

Tillers



- Widths of 66" & 78"
- Breaks up sod and clumps of soil
- Mixes compost and other materials
- Prepares soil for seeding or reseeding; great for small soil stabilization and landscape jobs
- Two position offset mount

Skid Steer Attachments

Skid steer & track loaders are more productive

ATTACHMENTS

Brush Cutters



- Available in 60", 72" & 78" widths
- High speed three blades for brush up to 4" diameter
- Heavy ¼" thick steel deck with formed side plates
- Available in standard or high flow
- New heavy duty motor and drive train

Trencher



- Available in digging depths of 36", 42" & 48"
- Trench digging widths of 6", 8" & 10"
- Equipped w/2 position side shift
- High torque hydraulic motor for maximum digging power
- Replaceable headshaft driven auger for spoil removal

Cold Planer

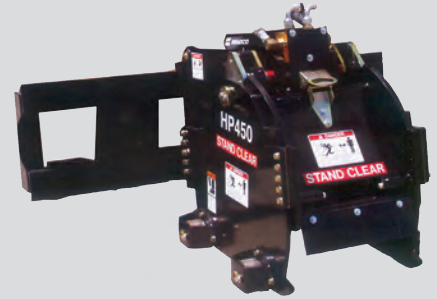

- High flow and standard flow models are available
- Planing widths of 12", 16", 18", 24", 30" & 40"
- Fully adjustable with electro-hydraulic controls
- Joystick controls for depth, tilt, and side shift
- Drum diameters of 19" & 22" with carbide picks

Root Rake



- Dual use - rip out roots and grapple material
- Widths of 72", 78" & 84"
- 49" Grapple opening
- Dual hydraulic cylinders
- Built for extreme duty use

Brush Shredder



- 66"/72"/78" Cutting width
- Front of deck swings up for cutting down trees
- Knocks down and shreds trees up to 7" in diameter
- 4 Reversible ¾" thick blades
- Optional carbide teeth stump grinder

Tilt Attach



- SSL quick attach with tilt
- Tilts implements 14 degrees right or left
- Large spherical ball bushing in center pivot allows extra strength and durability
- Abrasion resistant plate steel allows longer life
- Lift capacity of 4,200 pounds
- Tilts buckets and other implements for precise grading and leveling

Built By:



LG-13-P



LG-29-P



LG-45-SS



SPOT SERIES

15, 25 & 45 Gallon

FEATURES:

- Corrosion resistant polyethylene tank
- Full length drain sump
- 5" Fill lid with tether
- Larger hose wrap horns for hose storage
- Both gallon & liter fluid volume indicator on tank
- 12 Volt (demand) diaphragm pump
- Maximum horizontal throw - 30 ft.
- Maximum vertical throw - 18 ft.

MODEL #	GALLONS	G.P.M.	PSI	HANDGUN	HOSE	WT.
LG-13-P	15 Gal.	2.1 G.P.M.	60 PSI	Lever	15'	30#
LG-29-P	25 Gal.	2.1 G.P.M.	60 PSI	Lever	15'	35#
LG-45-SS	45 Gal.	4.5 G.P.M.	60 PSI	Pistol Grip	25'	90#

LG-45-SS



FEATURES:

- 45 gallon water tank
- Used for when water is needed for sprinkler system such as cold planers or sweepers
- Watering system reduces dust production and extends cutting and grinding components longevity
- Easily secured to roof with tie downs or straps (not supplied)
- 12 volt (demand) diaphragm pump

MODEL #	GALLONS	G.P.M.	PSI	WT.
LG-45-SS	45 Gal.	4.5 G.P.M.	60 PSI	90#

SPRAYER - 45 GAL. 3-PT

Our 45 gallon **3-Point Sprayer** applies pesticides, herbicides, insecticides or fungicides. The sprayer attaches in minutes to a Category I, 3-point hitch. The sprayer is equipped with a 4 nozzle spray boom allowing 120" of spray coverage. The 3 section boom features break-away hinges for transport or striking objects such as trees, while spraying.

FEATURES:

- 12 Volt High-Flo pump, 2.1 G.P.M., 60 PSI
- Break-away hinges on boom
- Fold behind 3 section boom
- Deluxe pistol grip handgun
- 15 Feet of hose



MODEL #	HITCH	GALLONS	G.P.M.	PUMP	WT.
LG-45-3PT-12V	Cat. I	45	2.1 G.P.M.	12V	80#

SPRAYERS

Our **Berm Sprayers** are available in capacities of 100 and 150 gallon. The booms can be quickly adjusted from 6 to 10 foot rows. The wind proof spray heads have flexible polyethylene brushes. The handy rear rails allow for easy mounting of vertical booms, horizontal booms and hose reels.

FEATURES:

- Cat. I, 3-point
- Capacity of 100 & 150 Gallon
- Telescopic square tubing frame
- Each head is equipped with two anti-drip spray nozzles 110° flat fan tips
- Spring break away protection to prevent damage to crop
- Includes hoses and shut-off valves
- Sprayer features on next page

Cat. 1, 3-point hitch berm sprayer



150 GALLON SPRAYER SHOWN

MODEL #	TANK CAPACITY	PUMP G.P.M./PSI	SPRAY HEADS	SPREAD	WT.
GC400-P2-BB	100 Gallon	11 / 360	2	6 to 10 feet	240#
GC600-P2-BB	150 Gallon	11 / 360	2	6 to 10 feet	275#

"GC" SERIES

You will achieve total versatility and economical performance from our two series of **3-Point Hitch Sprayers**. The rear rails on both series allows for easy mounting of a number of bolt-on attachments such as a vertical boom, horizontal booms, hose reels, and handguns. The sprayers feature reinforced polyethylene tanks suspended from a tubular steel frame to isolate the tanks. Also featured are piston diaphragm pumps and a hand wash tank for convenience and safety.



*150 Gallon
Shown With
Folding Boom*

FEATURES:

- Category I, 3-point hitch
- Polyethylene tanks with liquid level gauge
- Tank capacities of 50, 100, & 150 gallon
- High pressure piston diaphragm pumps
- Pressure regulator valve and gauge
- Large suction filter
- High pressure jet agitation
- Separate clean water tank for safety
- Rear mounted rails for mounting booms

MODEL #	TANK CAPACITY	PUMP GPM/PSI	WIDTH	HEIGHT	DEPTH	WT.
GC200-P2	50 Gal.	6/360	39"	46"	23"	175#
GC400-P2	100 Gal.	11/360	44"	44"	36"	190#
GC600-P2	150 Gal.	11/360	44"	56"	36"	225#

"GDL" SERIES

FEATURES:

- Category I & II, 3-point hitch
- Tanks are made of reinforced polyethylene with smooth lines that are gentle to plants
- High pressure 3 piston diaphragm pump
- Pressure regulator valve with manual controls
- Clean water 12 gallon tank for flushing chemical residue
- High pressure jet agitation
- Clean water 4 gallon tank for hand washing
- Optional - manual or hydraulic booms, hose reels and hoses



*Shown with
optional vertical boom,
hose reel and hose*

MODEL #	TANK CAPACITY	PUMP GPM/PSI	WIDTH	HEIGHT	DEPTH	WT.
GDL400-P1	100 Gallon	14 / 580	48"	45"	30"	350#
GDL600-P1	150 Gallon	14 / 580	48"	52"	30"	400#
GDL800-P1	200 Gallon	14 / 580	61"	55"	39"	425#

TRAILER SPRAYER

The **200 Gallon Sprayer** has a high volume and high pressure pump, best for multiple handgun use and with 20 and 28 foot booms. The simple design makes the sprayer easy to use. Recessed pump location allows close coupling to tractor and reduces angle of driveshaft. Tank is suspended from a heavy tubular frame to isolate it from vibration and stress.

- Mechanical agitation with stainless steel propeller and shaft
- Diaphragm pump produces 23 G.P.M. @ 780 PSI
- Cat. I or II, 3-pt. hitch 540 R.P.M., PTO driven
- Controls are reachable from tractor seat allowing operator to switch liquid from off to right or left spraying
- Optional - hydraulic foldaway spray booms in 20' & 28' widths

MODEL #	TANK CAPACITY	PUMP TYPE	PUMP GPM	PUMP PRESSURE	WT.
GN200D-23	200 Gal.	Diaphragm	23	780 PSI	450#

**MODEL GN200D-23
WITH 28'
HYDRAULIC BOOM**

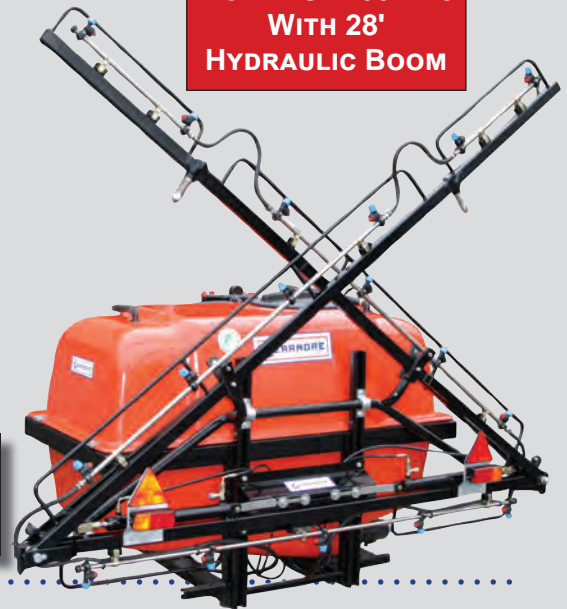

- 8 H.P. Honda engine
- Reinforced polyethylene tank w/2 hatches
- 3 Piston diaphragm pump, produces 14 G.P.M. at maximum pressure
- Pressure regulator w/manual controls reachable from seat
- Trailer tire size is 20 x 10.00- 6 ply



MODEL #	TYPE	WIDTH	LENGTH	HEIGHT	WT.
GPE800	Trailer	54"	102"	48"	490#

Our sprayer offers the latest design in an **All Purpose Sprayer**. The low profile polyethylene tank has a full length stainless steel agitation system and a large hatch with shower head to easily put wettable powder into suspension. An additional water filling hatch is included to keep chemicals from being splashed while filling. The sprayer can be used as a horizontal boom, hose/reel/handgun sprayer. The applications for this sprayer are endless - municipalities, golf courses, nurseries, farms, ranches, etc.

AIR BLAST SPRAYERS

- 20" Diameter fan with 9 adjustable blades
- Briggs & Stratton 9 H.P. Vanguard engine
- AR30 dual piston diaphragm pump produces 11 G.P.M., max. pressure 580 PSI
- Pressure regulator valve, gauge and hoses extend to towing vehicle
- High pressure jet agitation
- Separate clean water tank for hand washing

The Gearmore Compact, self contained Engine Driven **Air Blast Sprayers** was designed for very narrow rows and muddy conditions. This allows for operating the sprayer with an ATV or sub-compact tractors. The spray nozzles are easy to adjust and can be individually shut off. Controls allow for turning off one side. You can shut off the spray and disengage the fan for handgun spraying. This sprayer is popular in vineyards, berries, nurseries, hemp and other narrow row crops.



MODEL #	TYPE	GALLONS	FAN	WIDTH	LENGTH	HEIGHT	WT.
ATVM200	Trailer	50	17,280 cu. ft./min.	35"	81" - 91"	39" - 43"	445#
ATVM400	Trailer	100	17,280 cu. ft./min.	37"	85" - 93"	51" - 54"	485#

SPRAYERS

Value & Standard Series







For effective chemical spraying

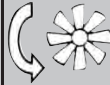

Our **Value Series Air Blast Sprayers** have outstanding features such as: reinforced smooth lines polyethylene tanks; hot galvanized frame and fan housing to prevent rust; top of the line smooth running 3 piston diaphragm pumps; high speed fans with adjustable blades; gearbox with neutral for handgun and boom operations; built-in fan deflectors to direct the spray where required. The sprayers even have a separate safety fresh water tank for hand washing.

FEATURES:

- Cat. I, 3-point hitch
- Tanks made of reinforced polyethylene with smooth lines - gentle to plants
- 3 Piston diaphragm pump 14 G.P.M., maximum pressure 580 PSI
- One speed gearbox with neutral for handgun and boom operations
- Stainless steel nozzle manifold
- High pressure jet agitation
- Adjustable top and bottom wings to direct air and spray only to the foliage
- Clean water 4 gallon tank for hand washing





						LBS.
MODEL - GAL.	INCH	R.P.M.	C.F.M.	NO.	H.P.	WT.
APLG200-P2-50	24"	2100	19,200	8	20 H.P.	300#
APLG400-P2-100	24"	2100	19,200	8	25 H.P.	375#

Our **Standard Series Air Blast Sprayers** are ideal for small to medium sized vineyards, orchards, berries, etc. The sprayers feature reinforced polyethylene tanks with smooth lines that are gentle to the plants. The tanks are suspended from heavy duty tubular steel frames to isolate it from vibration and stress. The gearboxes have a neutral position which shuts off the fan during handgun or boom work. The sprayers are easy to operate and have all the features required for easy maintenance and long life.

FEATURES:

- Cat. I & II, 3-point hitch
- 3 Diaphragm piston pump, 14 G.P.M. @ 580 PSI
- One speed gearbox with neutral
- High pressure jet agitation
- Stainless steel manifolds with anti-drip nozzles
- Clean water 12 gallon tank for flushing chemical residue
- Clean water 4 gallon tank for hand washing

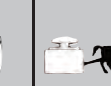

						LBS.
MODEL - GAL.	INCH	R.P.M.	C.F.M.	NO.	H.P.	WT.
APL400-P1-100 Gal.	28"	2,100	25,000	10	30 - 40	500#
APL600-P1-150 Gal.	28"	2,100	25,000	10	40 - 50	550#

Venturi Air Sprayers

For Berries, Open Fields and Hoop Houses

SPRAYERS

These sprayers were designed with unique distribution heads for berries. The narrow width allows for operating in the tight row spacings. The hoop house model has a cannon which sprays the "pole row". The open field distribution head has 6 double nozzles for spraying two half rows. Both distribution heads produce fog sized droplets that achieve total plant coverage.

FEATURES:

- Cat. I, 3-pt. hitch, PTO 540 R.P.M.
- High performance, precision balanced all steel centrifugal fan
- Special molded polyethylene fan housing
- Translucent heavy walled polyethylene tank with lid, sump and strainer basket
- Built-in overrunning clutch to protect the tractor and sprayer drive train
- Compact, rounded tank design permits traveling through vegetation without damaging it
- Simple, efficient "Dial-A-Rate", 15 position metering disc
- Agitation by liquid sparging tube & air from fan
- Low pressure spraying system - 15 to 40 PSI spraying pressure means less maintenance for pumps and nozzles
- Capable of application rates of 20 to 200 gallons per acre, depending on row width
- Reachable controls from tractor seat, allows operator to switch liquid from off to right, left, or both sides spraying
- Built-in 6 gallon fresh water safety tank

DISTRIBUTION HEADS:

Open Field Berries - Order 12 nozzle distribution head no T6M2D

Hoop House Berries - Order 12 nozzle distribution head no. T.6M+1C, which includes upper cannon assembly, shutter valve extension and 12 nozzle plugs



MODEL #	GALLONS	VOL. OF AIR	WIDTH	H.P. REQ'D	WT.
P42N1-300-G	75 Gallons	2,350	38"	18 H.P.	400#
P45N1-300-G	75 Gallons	3,180	38"	32 H.P.	410#

SPRAYERS

Venturi Air Sprayers

Fog sized droplets ensure total plant coverage

These *Venturi Air Sprayers* feature the 8 nozzle distribution head for vineyard rows up to 10 foot width.



**P45 SHOWN WITH
8 NOZZLE HEAD**



**FRONT
VIEW**



These unique *Venturi Air Sprayers* feature the latest technology in concentrate spraying. Thus, growers achieve the following benefits: spray atomization of droplets are smaller and more uniform, less fill-ups, even distribution of concentrated spray, complete foliage coverage, better product utilization, less chemical waste and soil/water contamination. All Venturi Air Sprayers shown on the following pages have these same advantages.

FEATURES:

- Cat. I, 3-point hitch, PTO 540 R.P.M.
- High performance, precision balanced all steel centrifugal fan
- Translucent heavy walled polyethylene tank with lid, sump and strainer basket
- Compact, rounded tank design permits traveling through vegetation without damaging it
- Simple, efficient "Dial-A-Rate", 15 position metering disc
- Agitation by liquid sparging tube and air from the fan
- Low pressure spraying system - 15 to 40 PSI spraying pressure means less maintenance for pumps and nozzles
- Power band fan speed-up is automatically adjusted by spring loaded idler
- Broad range of Venturi distribution heads that produce 50 micron droplets and are specially designed to match a variety of foliage profiles
- Capable of application rates of 20 to 200 gallons per acre, depending on row width
- Built-in 6 gallon fresh water safety tank

MODEL #	GALLONS	VOLUME OF AIR	WIDTH	H.P. REQUIRED	WT.
P42N1-300-G	75 Gallons	2,350 CFM	38"	18 H.P.	430#
P42N1-400-G	100 Gallons	2,350 CFM	44"	18 H.P.	450#
P45N1-300-G	75 Gallons	3,180 CFM	38"	32 H.P.	435#
P45N1-400-G	100 Gallons	3,180 CFM	44"	32 H.P.	455#

Cuts Spraying Time in Half
 Sprays two complete rows in one pass

VENTURI SPRAYERS



The **Venturi 2 Row Sprayer** covers two complete rows at one time so your spraying time is cut in half; reducing your labor, fuel, wear and tear on your tractor/sprayer, and since you are traveling every other row, you will have less soil compaction. Plant coverage is greatly increased because the spray enters the foliage from opposite directions at the same time. Thus, chemical drift is greatly reduced as the spray is held in the foliage longer. These sprayers are available with many different types of distribution heads, however the most productive is the unit shown above. The over the row nozzles are adjustable for 6 to 10 foot rows. The extensions have hydraulic cylinders for folding away when required.

FEATURES:

- Cat. I & II, 3-point hitch, PTO. 540 R.P.M.
- High performance, precision balanced all steel centrifugal fan
- Special molded polyethylene fan housing
- Translucent heavy walled polyethylene tank with lid, sump and strainer basket
- Compact, rounded tank design permits traveling through vegetation without damaging it
- Simple, efficient "Dial-A-Rate", 15 position metering disc
- Agitation by liquid sparging tube and air from the fan
- Low pressure spraying system - 15 to 40 PSI spraying pressure means less maintenance for pumps and nozzles
- Reachable controls from tractor seat, allows operator to switch liquid from off to right, left or both sides spraying
- Built-in 6 gallon fresh water safety tank

MODEL #	GALLONS	VOLUME OF AIR	WIDTH	H.P. REQUIRED	WT.
P50N1-400-G	100 Gallons	4,444	44"	45 H.P.	500#
P50S1-400-G	100 Gallons	4,875	44"	52 H.P.	500#
P50N1-600-G	150 Gallons	4,444	57"	45 H.P.	540#
P50S1-600-G	150 Gallons	4,875	57"	52 H.P.	540#



This model features fishtail type distribution heads for orchards with trees up to 35 feet in height. The fishtails are fitted with special manifolds with a total of 64 orifice outlets. This feature produces a fine mist spray to obtain total plant coverage. Also, growers have found that the sprayer is the most economical way to apply foliar feed.

The development of this sprayer was for horizontal spraying up to 90 feet. The system features 4 upper cannons, one central cannon and 4 lower nozzles. This cannon sprayer is popular in areas of limited tractor roads and is used in nurseries and crops like melons.



This sprayer has special tall tree cannons that will give complete coverage on trees up to 50 feet in height. The unit was designed for spraying walnuts, avocados, and other tall tree orchards. The sprayer is also excellent for applying foliar feed.



FEATURES:

- Cat. II, 3-point hitch, PTO, 540 R.P.M.
- Translucent heavy walled polyethylene tank with lid, sump and strainer basket
- Built-in overrunning clutch to protect the tractor and sprayer drive train
- Simple, efficient "Dial-A-Rate", 15 position metering disc
- Agitation by liquid sparging tube and air from the fan
- Low pressure spraying system - 15 to 40 PSI
- Electro valve controls to switch liquid from off to right, left or both sides spraying
- Built-in 6 gallon fresh water safety tank

MODEL #	GALLONS	VOLUME OF AIR	WIDTH	H.P. REQUIRED	WT.
P55E1-600-G	150 Gallons	9,123 CFM	57"	70 H.P.	550#

Venturi Air Sprayers

For Orchards that require top to bottom

SPRAYERS

These unique **Venturi Air Sprayers** feature our most powerful high speed turbine fans and are the latest technology in fine mist spraying. Thus, growers achieve the following benefits: Spray atomization of droplets are smaller and more uniform, less fill-ups, even distribution of concentrated spray, complete foliage coverage, better product utilization, less chemical waste and soil/water contamination. This 6 vent distribution head is also available on our 300 and 500 gallon trailer models.

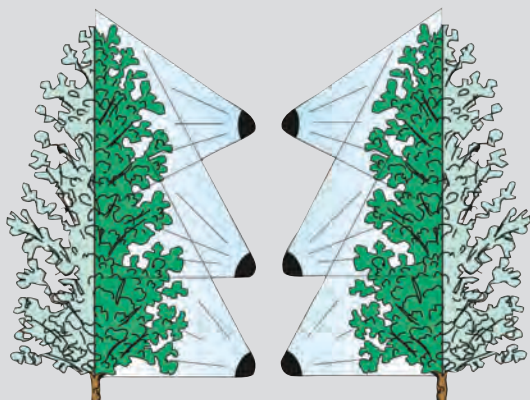

This sprayer produces a perfect curtain of fine fog sized droplets through special 6 vent distribution heads with a total of 96 orifice liquid outlets.

FEATURES:

- Cat. II, 3-point hitch, PTO, 540 R.P.M.
- High performance, precision balanced all steel centrifugal fan
- Translucent heavy walled polyethylene tank with lid, sump and strainer basket
- Compact, rounded tank design permits traveling through vegetation without damaging it
- Simple, efficient "Dial-A-Rate" 15 position metering discs
- Agitation by liquid sparging tube and air from fan
- Low pressure spraying system - 15 to 40 PSI spraying pressure means less maintenance for pumps and nozzles
- Reachable controls from tractor seat, allows operator to switch liquid from off to right, left or both sides spraying
- Built-in 6 gallon fresh water safety tank



MODEL #	GALLONS	CAT.	VOLUME OF AIR	WIDTH	H.P. REQ'D	WT.
P55E1-600E-6V	150	II	9,125 CFM	57"	70 H.P.	550#

SPRAYERS

Venturi Air 3-Pt./Link Designed so driveshaft is always straight in line



300 GAL. WITH OPT. DISTRIBUTION HEAD

These **Venturi Air Sprayers** feature a special short turning radius design. The fan and distribution head is 3-point hitch mounted. The trailer assembly is attached to the fan assembly with a heavy duty double knuckle joint. The sprayer can "turn on a dime"

with no stress or damage as the drive system is always straight. The sprayer shown is equipped with our unique 2 row distribution heads for spraying two complete rows with one pass. This cuts your spraying time in half, reducing labor, fuel, and wear and tear on your tractor/sprayer. These unique 3-point/trailer sprayers are the perfect units for narrow and short head land rows.

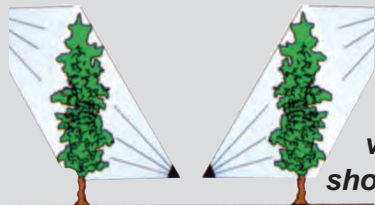

Developed especially for vineyards with short head lands.

FEATURES:

- Cat. I & II, 3-point hitch, PTO, 540 R.P.M.
- Turns as sharp as your tractor
- Parking stands for 3-point and trailer assemblies
- High performance, precision balanced all steel, front mounted centrifugal fan
- Special molded polyethylene fan housing
- Translucent heavy walled polyethylene tank with hinged lid, sump, strainer basket and shower head
- Dual tank lids for safety, one for water and one for adding chemicals

- Simple efficient "Dial-A-Rate", 15 position metering disc
- Centrifugal pump - 37 G.P.M.
- The 200 gallon has one pump, 300 gallon has 2 pumps
- Dual agitation systems, liquid and air
- Low pressure spraying system - 15 to 40 PSI spraying pressure means less maintenance for pumps and nozzles
- Power band fan speed-up is automatically adjusted by spring loaded idler
- Electro-valve controls allows operator to switch liquid to right, left or both sides spraying
- 8 Gallon fresh water safety tank

MODEL #	GALLONS	VOLUME OF AIR	WIDTH	LENGTH	TIRE SIZE	H.P. REQ'D	WT.
L50N1-800	200 Gallons	4,444 CFM	43"	9'	9.5Lx15-8 Ply	48 H.P.	855#
L50S1-800	200 Gallons	5,000 CFM	43"	9'	9.5Lx15-8 Ply	50 H.P.	855#
L50S2-1200	300 Gallons	5,000 CFM	54"	9'	11Lx15-8 Ply	52 H.P.	960#
L55E2-1200	300 Gallons	9,122 CFM	55"	10'	11Lx15-8 Ply	64 H.P.	1,200#

200 Gallon Trailer

For low horsepower tractors spraying narrow rows

VENTURI SPRAYERS

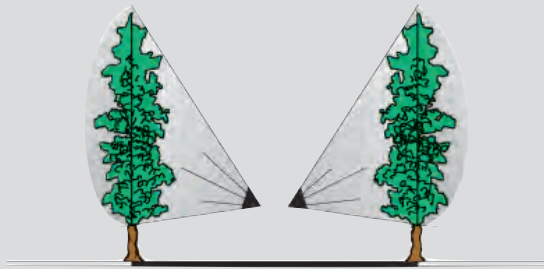

2 Half Rows



FEATURES:

- Trailer mounted, PTO, 540 R.P.M.
- Translucent heavy walled polyethylene tank with hinged lid, sump, strainer basket and shower head
- Unique polyethylene belly mounted air tubing to the distributor heads
- Dual tank lids for safety, one for water and one for adding chemicals
- Compact, rounded tank design permits traveling through vegetation without damaging it
- Adjustable tread width, facilitates matching sprayer tread with tractor tread
- Tongue with clevis hitch has length adjustment
- Simple, efficient "Dial-A-Rate", 15 position metering disc
- Dual agitation systems, liquid and air
- Low pressure spraying system - 15 to 40 PSI spraying pressure means less maintenance for pumps and nozzles
- Built-in overrunning clutch to protect the tractor and sprayer drive train
- Power band fan speed-up is automatically adjusted by spring loaded idler
- Electro-valve controls to allow operator to switch liquid from off to right, left, or both sides spraying
- Built-in 8 gallon fresh water safety tank



Our **200 Gallon Trailer Mounted Sprayer** was developed for low horsepower tractors doing narrow row spraying. Tractors with PTO. horsepower of as low as 36 will handle this sprayer. The 48 inch overall sprayer width allows for operating in the narrowest of rows. Growers achieve the following additional benefits - spray atomization of droplets are smaller and more uniform, less fill-ups, even distribution of concentrated spray, complete foliage coverage, better product utilization, less chemical waste and soil/water contamination.

MODEL #	GALLONS	VOLUME OF AIR	WIDTH	LENGTH	TIRE SIZE	H.P. REQ'D	WT.
T45N1-800	200 Gallon	3,180 CFM	48"	10' - 5"	9.5Lx15-8 Ply	36 H.P.	910#

SPRAYERS

Venturi Air, 200 & 300 Gallon

For high production, accurate spraying



2 Complete Rows

The **Gearmore T50S 2 Row Venturi Air Sprayer** covers two complete rows at one time so your spraying time is cut in half; reducing your labor, fuel, wear and tear on your tractor/sprayer, and since you are traveling every other row you will have less soil compaction. Plant coverage is greatly increased because the spray enters the foliage from opposite directions at the same time. Thus, chemical drift is greatly reduced as the spray is held in the foliage longer. The Venturi low volume spraying system also achieves these additional benefits: spray atomization of droplets are smaller and more uniform, even distribution of concentrated spray, better product utilization, less chemical waste and soil/water contamination and best of all less fill-ups.

2 ROW BOOM FEATURES:

- For 6 to 10 foot rows
- Total of 4 distribution heads with 4 Venturi nozzles on each head with individual shut off valves, rotating calibration discs and anti-drip valves
- Rear mounted height adjustable frame
- Two hydraulic cylinders with hoses for opening and closing horizontal booms

FEATURES:

- Molded polyethylene 200 or 300 gallon tank
- Sprayer operates with a low pressure centrifugal pump which produces 37 G.P.M. at the normal operating pressure of 15 to 40 PSI
- Dual centrifugal pumps - 37 G.P.M. for spraying and 37 G.P.M. for agitation on 300 gallon only
- Air speed is 415 M.P.H. at nozzles
- Wheels are adjustable up or down, front or rear, in or out to obtain the best balance
- Electro-valve system controls spray off or both sides spray, right or left only
- Separate water and chemical filling hatches keep chemical from being splashed out while filling
- No gearbox for fan speed-up, only a simple power band pulley system with overrunning clutch
- High speed turbine fan turns at 4,320 R.P.M. with air delivery of 4885 cu. ft. per minute
- Separate safety clean water 8 gallon tank for handwashing

MODEL #	GALLONS	VOLUME OF AIR	WIDTH	LENGTH	TIRE SIZE	H.P. REQ'D	WT.
T50S2-800	200	4,885 CFM	42" to 50"	10'-5"	9.5Lx15-8 Ply	48	910#
T50S2-1200	300	4,885 CFM	54" to 74"	11'-7"	11Lx15-8 Ply	52	1,020#

Dimensions are less 2 row distribution head

Venturi Air

Total plant coverage at lowest cost per acre

SPRAYERS

These unique **Venturi Air Sprayers** feature our most powerful high speed turbine fans and are the latest technology in spraying. Thus, growers achieve the following benefits: spray atomization of droplets are smaller and more uniform, less fill-ups, even distribution of concentrated spray, complete foliage coverage, better product utilization, less chemical waste and soil/water contamination.

FEATURES:

- High performance, precision balanced all steel, front mounted, centrifugal fan
- Translucent heavy walled polyethylene tank with hinged lid, sump, strainer basket and showerhead
- Dual centrifugal pumps - 37 G.P.M. for spraying and for agitation
- Dual agitation systems, liquid and air
- Low pressure spraying system - 15 to 40 PSI spraying pressure means less maintenance for pumps and nozzles
- The Venturi Air distribution heads produce 50 micron droplets and are specially designed to match a variety of foliage profiles
- Electro-valve controls to allow operator to switch liquid from off to right, left, or both sides spraying
- Built-in 8 gallon fresh water safety tank

10 Different distribution heads to choose from for multiple crops

OUR 12 NOZZLE CANNON HEAD WILL SPRAY UP TO 50 FOOT TREES



"10 YEAR WARRANTY ON POLYETHYLENE TRAILER TANKS"

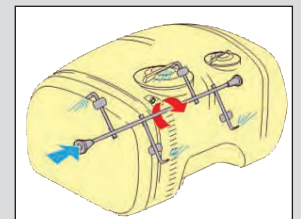

Centrifugal pump powers rotating liquid agitation system to insure product mix



MODEL #	GALLONS	VOLUME OF AIR	MIN. WIDTH	LENGTH	TIRE SIZE	H.P. REQ'D	WT.
T55E2-1200	300 Gal.	9,123 CFM	55"	12'	11Lx15-8 Ply	64 H.P.	1,020#
T55E2-1500	400 Gal.	9,123 CFM	66"	14'	11Lx15-8 Ply	70 H.P.	1,240#
T55E2-2000	500 Gal.	9,123 CFM	71"	14'	12.5Lx15-10 Ply	74 H.P.	1,320#

SPRAYERS

Venturi Air for spraying tall trees and hops

NEW

To insure total coverage in dense, tall trees and Hops; our Cannon Sprayers are the answer. The spray will reach up to 50 feet. Extensions are available on upper cannons, if required. These unique Venturi Air Sprayers feature our most powerful high speed turbine fans and are the latest technology in fine micron droplets spraying. Thus, growers achieve the following benefits: spray atomization of droplets are smaller and more uniform, less fill-ups, even distribution of concentrated spray, complete foliage coverage, better product utilization, less chemical wastes and soil/water contamination.



16 nozzle cannon head spray up to 50 foot trees



Hops distribution head with 7 upper cannons and 2 large lower fishtail nozzles with 128 spray outlets.

FEATURES:

- Molded polyethylene 800 gallon tank
- Translucent heavy walled tanks with hinged lid, strainer basket and shower head
- High performance precision balanced all steel, front mounted turbine fan
- Dual centrifugal pumps - 37 G.P.M. for spraying and 37 G.P.M. for agitation
- Low pressure spraying system - 15 to 40 PSI spraying pressure means less maintenance on pumps and nozzles
- Electro valve system controls spray off or on, both sides spray, and right or left only
- No gearbox for fan speed-up, unique simple power band system with built-in overrunning clutch
- Separate safety clean water 8 gallon tank for hand washing
- Dolly wheel adjustable parking stand

MODEL #	GALLONS	VOLUME OF AIR	WIDTH	LENGTH	TIRE SIZE	H.P. REQ'D	WT.
T55EA-3000-G*	800	9,123 CFM	86"	22'	15.0/55-17	100	2,545#
Sprayer only, add distribution head							

With Wrap-A-Round Booms

For high production, accurate spraying

SPRAYERS

**500 GALLON SPRAYER
SHOWN WITH "D" BOOM**



We custom build booms and electro / hydraulic controls to grower's requirements

Now available is a complete series of high strength **Wrap-A-Round Spray Booms**.

The booms feature extra strong framing with heavier support tubings to the sprayer frame. The five hydraulic cylinders give total control on height adjustment, swing up for in row obstructions, and fold away for transport. The width adjustment is manual, optional electro cylinders operated from the tractor seat are available. These booms are available to spray two complete rows or two complete rows and two half rows. Boom controls require 5 rear remotes or Gearmore's optional electro over hydraulic kits. The booms are designed to fit the popular 300 and 500 gallon Venturi Air Sprayer.

FEATURES:

- Sprayer features same as previous page
- Booms swing hydraulically from operational to closed position
- Booms fold forward for transport and lock
- Height adjustment is hydraulic
- Boom bottoms can be fitted with single or double 4 + 4 nozzles or fishtails
- Boom tops can be fitted with 4 + 4 nozzles, cannons or fishtails



BOOM MODEL #	SPRAYER MODEL #	GALS.	NO. OF ROWS	NOZZLE ASSY.'S	ROW SPACE	CROP MAX. HT.	BOOM CLEARANCE	NOZZLE POSITIONS	BOTTOM NOZZLES	TOP NOZZLES
TS56MB55M12 "A" Boom	T55E2-1200	300	2-Full 2-Half	6	7.5'-10'	7 ft.	8 ½ ft.	Bottom Only	4 Outlet Head	None
TS56MC55D12 "A" Boom	T55E2-2000	500	2-Full 2-Half	6	9.5'-13'	8 ft.	9 ½ ft.	Bottom Only	4 Outlet Head	None
TS54M4CC55D12 "B" Boom	T55E2-2000	500	2-Full	8	9.5'-13'	8 ft.	9 ½ ft.	Top & Bottom	4 Outlet Head	Cannons
TS512MC55D12 "D" Boom	T55E2-2000	500	2-Full 2-Half	12	9.5'-13'	8 ft.	9 ½ ft.	Top & Bottom	4 Outlet Head Bottom & Top	
TS52V4V6V55D12 Hedge Row	T55E2-2000	500	2-Full	12	9.5'-13'	8 ft.	9 ½ ft.	Top, Center & Bottom	Fishtail Head Bottom, Center & Top	

SPRAYERS

Venturi Air Boom Achieve total plant coverage on field crops

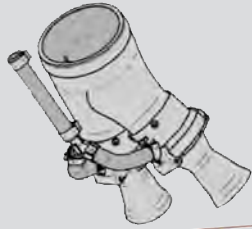

Distribution outlet with two nozzles, adjustable in height and width, and revolving in all directions

**27' BOOM
SPRAYER SHOWN**

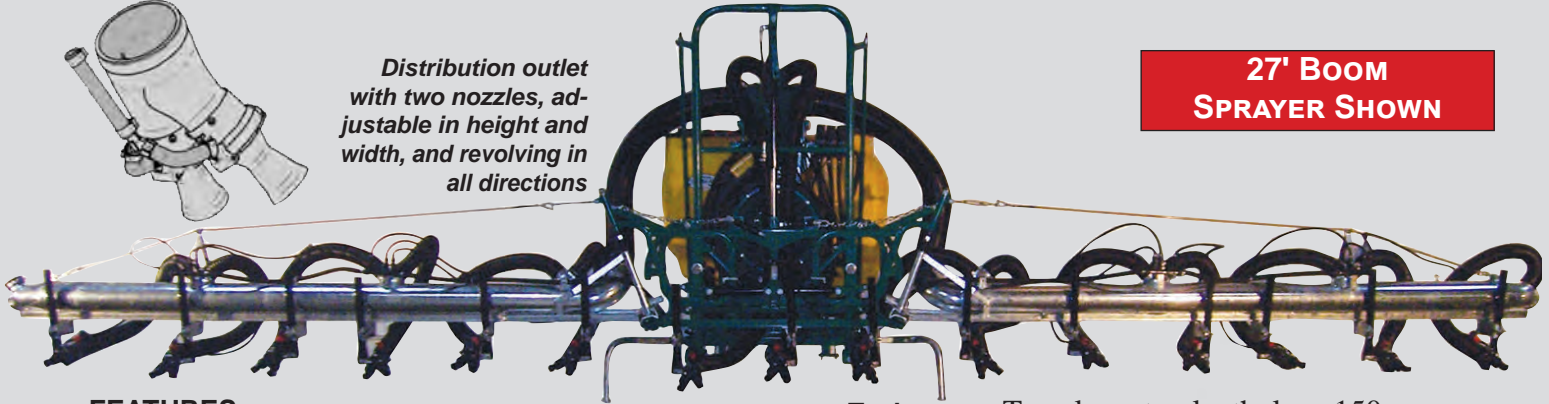

FEATURES:

- Nozzles break down spray to fog size (50 microns) droplets which penetrate in and around all areas of each plant
- Air movement allows chemical to completely cover vegetation, especially the underside of leaves
- Volume as low as 5 gallons per acre results in fewer refilling stops and more acres covered per day
- Spray drift is reduced by 50% to 75%.
- Boom has breakaway and hydraulic fold away features to prevent damage and for transport
- Boom raises and lowers hydraulically for different crop heights, independent of the sprayer
- Boom nozzles are completely adjustable in width and angle for maximum coverage
- Chemicals only come in contact with plastic, rubber, and stainless steel parts

- Tank:** Translucent polyethylene 150 gal. with hatch & strainer basket
- Agitation:** Adjustable liquid bypass, and air from fan when required
- Drive:** 540 R.P.M PTO. driven with belt drive to fan and pump with overrunning clutch
- Nozzles:** "No drip" system on each nozzle and individual liquid shut-off by hand, replaceable stainless steel discs and screens
- Controls:** Electro-valve controls allows operator to switch liquid from off to right, left or center
- Filtration System:** 3 Stages - at filler, at pump, and at nozzles
- Fan:** Centrifugal type w/PVC housing
- Pump:** Centrifugal with maximum 37 G.P.M.
- Sight Gauges:** In tank and tubing
- Pressure Gauge:** 0 to 80 P.S.I. in liquid case to reduce vibration and extend life



40' Boom Sprayer Shown

Special booms built upon request

MODEL #	BOOM	ROWS	NO. OF NOZ.	BOOM DESIGN	TANK CAP.	FAN DIA.	FAN (RPM)	VOL. OF AIR	AIR SPEED FOLIAGE	CON-TROLS	MIN. TR. H.P.	WT.
P45N-400-23	23'	5	2+2=20	Galvanized Tubing	100 Gal.	17.75"	4,000	3,180	10-50 MPH	Liquid	32 H.P.	700#
P50S-600-27	27'	8	2+2=32	Galvanized Tubing	150 Gal.	19.75"	4,320	4,875	10-50 MPH	Electro Valve	52 H.P.	1,230#
P55E1-600-40S	40'	7	2+3+2=49	Galvanized Tubing	150 Gal.	21.75"	3,900	9,123	10-50 MPH	Electro Valve	64 H.P.	1,800#
P55E1-600-40	40'	12	2+2=48	Galvanized Tubing	150 Gal.	21.75"	3,900	9,123	10-50 MPH	Electro Valve	64 H.P.	1,800#

3-Point/Trailer Spinner Spreaders

3-Point, PTO & ground driven with PVC hoppers

SPREADERS

3-PT. SEEDER/SPREADERS



Our **3-Point Hitch Spreaders** feature a strong, corrosion proof PVC hopper. These spinner units have double levers and stainless steel slides which allow for spreading at 180° or 90° to the right or left. They are ideal for even spreading fertilizer, seed, salt, and other flowable materials.

FEATURES:

- Cat. I, 3-point hitch, 540 PTO
- Corrosion proof PVC hopper
- Stainless steel spreading disc with 4 stainless steel fins
- Steel oil tight gearbox with grease zerk
- Extended handle for engaging & disengaging
- Choice of 3 spread patterns: full rear, left or right side
- Effective spreading width from 20' to 46'
- Built in rear hitch
- Adjustable uniform rates from 20 to 900 lbs./acre

OPTIONS:

- ~ Larger extended hopper agitator
- ~ One and two row band spreader attachments

MODEL #	CAPACITY		OVERALL HEIGHT	WT.
	LBS.	CU. FT.		
PL180	480 lbs.	5.8 cu. ft.	36"	120#
PL500	1,000 lbs.	12.3 cu. ft.	45"	140#

TRAILER MOUNTED SEEDER / SPREADERS



Our **Seeder/Spreader** is a self contained, towable implement that can be operated by almost any vehicle. This unit has a ground driven, cast iron, oil bath gearbox that can be disengaged when transporting. It is ideal for spreading seed, fertilizer, sand, and salt. The large 16" diameter x 6.5" wide tires make this a "Turf Friendly" implement. This spreader is a handy tool for farmers, landscapers, and homeowners.

- Ground wheel driven
- Corrosion proof PVC hopper
- Cast iron, oil bath gearbox
- Gearbox disengages for transport
- Extended handle for engaging and disengaging material flow
- Stainless steel spreading disc with 4 stainless steel fins
- 16 x 6.5-8 Ply turf tires
- 1 7/8" Ball hitch
- Spreading widths from 20' to 46'
- 3 Spread patterns:
 - ~ full rear
 - ~ left side
 - ~ right side

MODEL #	CAPACITY		HEIGHT	WIDTH	DEPTH	WT.
	LBS.	CU. FT.				
PTP180-P	480 lbs.	5.8 cu. ft.	51"	41"	59"	175#
PTP300-P	765 lbs.	9.2 cu. ft.	51"	41"	59"	185#

SPREADERS

Spinner Spreaders High capacity, 3-point PTO driven

Our high capacity **3-Point Spreader** features a stainless steel, single spinner disc with 6 stainless steel vanes. Spreaders have a heavy duty stamped and ribbed frame. All metal hoppers and frames have special phosphated undercoat, then epoxy powder painted and baked at 300 degrees to insure long life. The spreader can be set at 180°, 90° right, or 90° left spreading pattern.

SINGLE SPINNER



FEATURES:

- Cat. II, 3-point hitch
- Low loading height
- Sturdy stamped and ribbed steel frame
- Manual levers control on and off
- 6 Fins spreading disc for even spreading width
- Spreading width from 32' to 59'

MODEL #	CAPACITY		HEIGHT	WIDTH	DEPTH	WT.
	LBS.	CU. FT.				
RT-800	1,700 lbs.	28 cu. ft.	40"	59"	53"	345#

Our 2,300 pound, 35 cu. ft. capacity spreader features twin stainless steel spinner discs, which are extremely accurate with only 6.7% variance across the spread pattern. Hydraulic cylinders opening and closing shutters for both the right and left hand spinner discs. The lever allows for easily setting the spreader for 180°, 90° right or 90° left hand spread. An important option is the two row band spread attachment for spreading material down row lines.

DOUBLE SPINNER



Shown With Optional 2 Row Band Spreader Attachment

FEATURES:

- Cat. I & II, 3-point hitch
- Hydraulic cylinder controls, off and on
- Stainless steel construction
- Two stainless steel disc with 3 vanes each
- Spreading width from 30 to 50 feet
- Easy on and off band spread attachment for exact material placement
- Optional two row band spreader attachment - 66" wide

MODEL #	CAPACITY		HEIGHT	WIDTH	DEPTH	WT.
	LBS.	CU. FT.				
RE-A-1000	2,300 lbs.	35 cu. ft.	45"	59"	51"	450#

PULL TYPE SEEDER / SPREADER



Our **Seeder/Spreader** is a self contained, towable implement that can be operated by almost any vehicle. This unit has a ground driven, cast iron, gearbox that can be disengaged when transporting. It is ideal for spreading seed, fertilizer, sand, and salt. The large 20" diameter x 10" wide tires make this a "Turf Friendly" implement. The spreader features a cable control that allows the operator to adjust spread rate and turn the spreader on and off from the vehicle seat. This is a popular, economical spreader for golf courses, parks, sport fields, and turf farms.

FEATURES:

- Remote cable control from vehicle
- Agitators to prevent bridging
- 20 x 10:00 - 8 tires
- Full width or spreading to one side
- Height adjustment on 2" ball hitch

OPTIONS:

- ~ Secondary chain agitator
- ~ Canvas hopper cover
- ~ Cable control mounting bracket
- ~ Deflector for salt and sand

MODEL #	CAPACITY		SPREADING WIDTH	MACHINE			WT.
	LBS.	CU. FT.		HEIGHT	WIDTH	DEPTH	
PTB560	1,070 lbs.	14.2 cu. ft.	Max. 52'	51"	65"	96"	310#

COMPOST SPREADER



This unique **Compost Spreader** is able to spread a wide range of materials such as: compost, peat, concentrated manure, lime, gypsum, dried grape pomace and other types of fertilizer. The spreader was designed for two different spreading operations. You can broadcast spread and add the side conveyor for band spreading. Features are built into the spreader to achieve the application of this large group of products. Patented two gearbox system, one to power the spinner and a second gearbox geared to a low R.P.M. for the agitator.

FEATURES:

- Cat. I & II, 3-point hitch, 540 R.P.M. PTO
- Spinner turns at 718 R.P.M. and the agitator turns at 77 R.P.M.
- Hydraulic cylinder for on and off
- For tractors 50 to 150 H.P., capacity - 35.3 cu. ft.
- Spread width 20 to 45 ft., up to 12 ft. with band spread attachment
- Agitation blades for light compost

OPTIONS:

- ~ Stainless steel side band attachment
- ~ Stainless steel rear drop discharge

MODEL #	CAPACITY	WIDTH	DEPTH	HEIGHT	WT.
SCU-N1000	2,000 lbs.	48"	64"	55"	780#

SPREADERS

Pendulum Spreaders

Achieves accurate placement of fertilizers and seeds

Our line of *Pendulum Spreaders* feature an advanced mechanism with regulating key which allows for quickly setting the spread pattern. Other features are exact rate/spread control, quick change spouts, low filling heights, and easy maintenance. All models have formed fiberglass hoppers. The spreading width with the standard spout is 20 to 46 feet. A large variety of spouts are available for standard broadcast, narrow row and wide row vineyards and orchards. Hopper capacities from 1,125 to 2,000 pounds.

MODEL PDC400

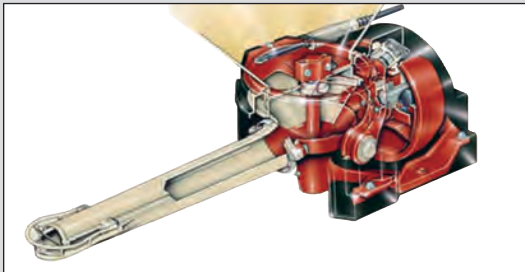

The above spouts fit all models



MODEL PDV500

MODEL #	HITCH CATEGORY	CAPACITY		OVERALL WIDTH	OVERALL HEIGHT	WT.
		LBS.	CU. FT.			
PDC400	Cat. I	925 lbs.	13.6 cu. ft.	46"	47"	225#
PDV500	Cat. I & II	1,155 lbs.	17 cu. ft.	54"	36"	290#
PDV600	Cat. I & II	1,450 lbs.	20.5 cu. ft.	54"	40"	315#
PDHV800	Cat. II	2,000 lbs.	32 cu. ft.	74"	40"	375#



Our Skid Steer mount loader hydraulic drive collection sweeper handles light and heavy duty clean up in construction, municipal and industrial applications. Enhanced front bumper guard for better protection during operation. Narrower overall attachment width for improved mobility and cleanup in confined areas. The brush head is reversible for "dust panning" debris. Units dump by hydraulic lift arms. The brushes have a quick changing feature. The sweeper is available in widths of 5, 6, & 7 feet.

FEATURES:

- SSL quick attach mounting bracket
- Replaceable bolt on cut edge
- The 26" diameter brushes come in half wire & poly or all poly
- Available gallon per minutes of 15-25, Max PSI 3,500

OPTIONS:

- ~ Tank & Sprinkler system
- ~ Gutter brush

NOTE: Sweepers are available as "Cold Planter Special" with dense wafer brushes the width of the cold planter cut. Designed to clean out the milled grooves.

MODEL #	SWEEPING WIDTH	OVERALL WIDTH	WT.
21560M-0022	60"	72.5"	946#
21572M-0022	72"	84.5"	1,068#
21584M-0022	84"	96.5"	1,190#

Built By:



SWEEPERS

Contact Us for Complete Catalog
Many more models available

3Pt. PTO Sweeper

3Pt. PTO driven Angle Sweepers available for compact and full size tractors. These brooms are ideal for snow removal, general cleanup and construction. Available in hydraulic or manual angle with 24" and 32" diameter brush. Widths from 4' to 8'



MODEL #	WIDTH	PATH @ 30° ANGLE	WEIGHT	HORSEPOWER
RMRM5	60"	52"	430#	-30 H.P.
RMRM6	72"	64"	490#	-30 H.P.
RHFA6	72"	64"	850#	30+ H.P.
RHFH7	84"	76"	950#	30+ H.P.



Angle Sweeper

Angle Sweepers mount to skid steer loaders and is available for mounting on utility tractor loaders. Hydraulic brush drive, with manual or hydraulic angle change 30° left/right available. Single or dual motor configurations are available. Brush is equipped with a quick change core for easy brush change. Heavy duty design with quick attach mounting with 32" brushes.

Built By:



MODEL #	WIDTH	PATH @ 30° ANGLE	WEIGHT	G.P.M.
22072	72"	62.5"	895#	12 - 25
22084	84"	73"	945#	12 - 25
22096	96"	83"	995#	12 - 25

"B" & "C" Series

For tractors 15 to 45 horsepower

ROTARY TILLERS

These compact **"B" Series** tillers are quality constructed units that are built to last. The adjustable skid shoes control the cutting depth while the rear tailboard controls the soil mix. The tiller is equipped with a slip clutch to protect the tiller and tractor. Ideal for preparing seedbeds, renovating pastures, and other tillage uses. The tiller provides uniform mix throughout the cultivated depth.



Cat. I
A.S.A.E.
Quick Hitch
Compatible

FEATURES:

- Cat. I, 3-point hitch
- 7" Approximate tilling depth
- One speed gearbox, 540 R.P.M.
- 80# Heavy duty roller chain
- Slip clutch driveshaft protects tractor & tiller drive system
- Curved saber style, heat treated, long wearing tines
- 6 Tines mounted on each rotor plate for maximum tilling action
- Tines staggered in scroll design for easy soil penetration
- Side mounted skids for depth control

MODEL #	TILLING WIDTH	OVERALL WIDTH	NO. OF TINES	APPROX. H.P.	WT.
B100	40"	44"	30	20 H.P.	300#
B120	48"	52"	36	25 H.P.	335#

"C" SERIES FOR COMPACT TRACTORS 20 TO 45 H.P.

FEATURES:

- Strong, smooth running, all gear final drive
- Slip clutch driveshaft to protect tractor and tiller drive system
- Curved saber style, heat treated, long wearing tines
- 6 Tines mounted on each rotor plate for maximum tilling action
- Tines staggered in scroll design for easy soil penetration
- Powder coated, baked-on paint to reduce corrosion
- Cat. I, 3-point hitch
- 8" Approximate tilling depth
- One speed gearbox, 540 R.P.M.



Cat. I
A.S.A.E.
Quick Hitch
Compatible

MODEL #	TILLING WIDTH	OVERALL WIDTH	NO. OF TINES	APPROX. H.P.	WT.
C85	34"	38"	24	20 H.P.	450#
C105	42"	46"	30	25 H.P.	485#
C125	50"	54"	36	30 H.P.	510#
C145	56"	60"	42	35 H.P.	545#
C165	65"	69"	48	40 H.P.	590#
C185	72"	76"	54	45 H.P.	640#

Our **"C" Series** has a number of special features that are standard, such as; slip clutch, all gear final drive, 6 tines per rotor plate, and heavy A.S.A.E. quick hitch A-frame. Excellent tiller for vegetable growers, landscapers, nurseries, vineyards, and general maintenance operations.

ROTARY TILLERS

"E" & "N" Series
For tractors 20 to 70 horsepower

Reverse Rotation E Series in 60" and 72" tilling widths. The counter rotation greatly aids in operating in hard ground. The reverse rotation achieves more depth and pulverizes the soil, plus buries clods, stones and debris. Ideal for preparation of seedbeds, renovation of pastures, orchards, vineyards and mulching-in cover crops and stubble. Provides uniform mixture through-out cultivated depth. Produces loose textured soil that holds moisture, reduces erosion.



Reverse Rotation

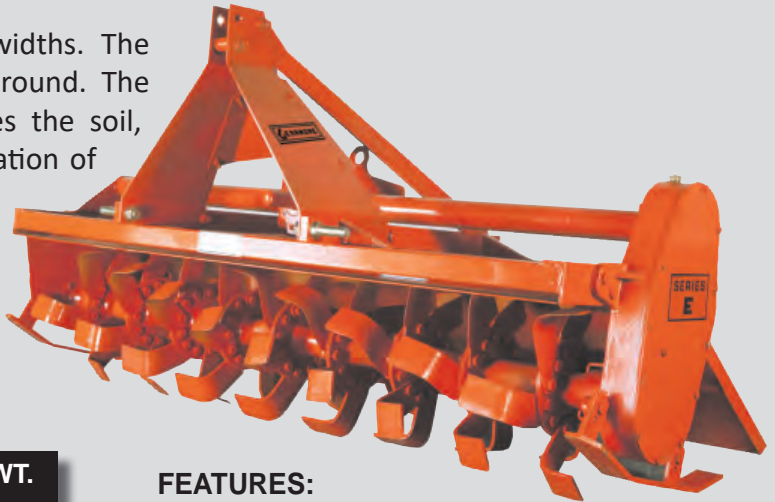

FEATURES:

- Connects to 3-point hitch
Cat. I, 540 R.P.M. tractors-7' Cat I & II
- All gear, final drive
- Rugged construction for long life
- Heat treated, long wearing tines
- 6 - L shaped tines per flange
- Adjustable skids for depth control
- Torque tube frame to absorb shock loads
- Driveshaft with slip clutch
- Up to 70 H.P. - E84 only

MODEL #	TILLING WIDTH	OVERALL WIDTH	NO. OF TINES	APPROX. H.P.	WT.
E48	48"	53"	36	20-35 H.P.	600#
E60	60"	65"	42	25-40 H.P.	690#
E72	72"	77"	54	35-45 H.P.	780#
E84	84"	89"	66	50-70 H.P.	805#
E60R*	60"	65"	42	40-45 H.P.	710#
E72R*	72"	77"	54	45-50 H.P.	800#

*R - Reverse Rotation

"N" SERIES FOR TRACTORS 40 TO 70 H.P.

These medium duty **"N" Series** tillers feature a smooth running, all gear drive system. Powered through a heavy 70 horsepower gearbox to an all gear final drive. The tilling action provides a uniform mixture throughout the cultivated depth. Producing loose textured soil that holds moisture and reduces erosion. These are the ideal tillers for farm, vineyard, orchards, landscapers, nurseries, etc.

FEATURES:

- Cat. I & II, 3-point hitch
- 8" Approximate tilling depth
- One speed gearbox, 540 R.P.M.
- Strong, smooth running, all gear final drive
- Slip clutch driveshaft to protect tractor and tiller drive system
- Curved saber style, heat treated, long wearing tines
- Tines staggered in scroll design for easy soil penetration
- Powder coated, baked-on paint to reduce corrosion
- Side mounted skids for depth control



MODEL #	TILLING WIDTH	OVERALL WIDTH	NO. OF TINES	APPROX. H.P.	WT.
N130	51"	57"	30	40 H.P.	780#
N155	61"	67"	36	50 H.P.	895#
N180	71"	77"	42	60 H.P.	970#
N205	81"	87"	48	70 H.P.	1,045#

"S" & "T" Series

For tractors 50 to 160 horsepower

ROTARY TILLERS



CAT II
A. S. A. E.
QUICK
HITCH
COMPATIBLE

These **"S" Series Tillers** were designed for high usage in agricultural and industrial applications. At a depth of 8 inches, the saber tines produce a uniform mixture of loose, textured soil that holds moisture and reduces erosion. These tillers are extremely well built, with 4 speed gearbox, all gear final drive and slip clutch driveshaft for heavy duty use. There is no better tool for preparation of seedbeds.

FEATURES:

- Cat. II fixed center mount
- 120 H.P., 4 speed gearbox
- 4-speeds at 540 R.P.M.
- All gear final drive
- Slip clutch driveshaft
- 6 Tines on each rotor plate - staggered
- Torque tubing frame to absorb shock loads
- Adjustable skids for depth control

MODEL #	TILLING WIDTH	OVERALL WIDTH	NO. OF TINES	APPROX. H.P.	WT.
S160-CT	63"	68"	36	50 H.P.	1,066#
S180-CT	73"	78"	42	60 H.P.	1,255#
S205-CT	83"	89"	48	70 H.P.	1,350#
S230-CT	92"	99"	54	80 H.P.	1,430#
S255-CT	102"	107"	60	120 H.P.	1,490#

CT in model number stands for Tungsten Coated Tines

"T" SERIES FOR TRACTORS 90 TO 160 H.P.



These **"T" Series Tillers** were designed for high horsepower tractors to produce a finished seedbed in a single pass. For crops such as vegetables, timing is everything. The basic plow, disc, cultivator tilling operation requires too many passes, wasted fuel, and causes excessive compaction. The saber tines produce a uniform mixture of loose, textured soil that holds moisture and reduces erosion. There is no better tool for preparation of seedbeds and incorporating crop residue.

FEATURES:

- Cat. II, 3-point hitch, fixed center mount
- For tractors up to a maximum of 160 H.P.
- Cast iron cover for the strong smooth running all gear final drive
- Oil bath side transmission with oil level sight glass
- Gearbox supported by full length tubes for added support
- 10" Approximate tilling depth
- 4 Speed gearbox - 2 speeds @ 540 R.P.M. & 2 speeds @ 1,000 R.P.M.

- Strong, smooth running, all gear final drive
- Curved, saber style heat treated, long wearing tines
- Slip clutch driveshaft to protect tractor and tiller drive system
- Side mounted skids for depth control
- 6 Tines mounted on each rotor plate for maximum tilling action
- Large, oil bath, long wearing rotor bearings

MODEL #	TILLING WIDTH	OVERALL WIDTH	NO. OF TINES	APPROX. H.P.	WT.
T230-CT	90"	97"	54	90-100	2,140#
T280-CT	110"	117"	66	100-120	2,205#
T305-CT	120"	127"	72	120-160	2,275#
T355-CT	140"	147"	84	120-160	2,415#

"S" INCORPORATORS Rotary Tillers w/Rollers

For year round floor maintenance

An important application for this tiller with rear roller is to bury wood chips by tilling 2 to 3 inches deep. The roller then slightly compacts and smooths out the vineyard and orchard floors. The wood chips will decompose at a faster rate and the rolled out area is then in better condition for the harvesters.

Growers have found many more uses for the **Incorporators**. Such as - tilling out tractor tire tracks, mulching in weeds and general floor maintenance.

TILLER FEATURES:

- Cat. II, 3-point hitch
- A.S.A.E. quick hitch compatibility for easy hook-up
- 4 Speeds @ 540 R.P.M.
- Strong, smooth running, all gear final drive
- Slip clutch driveshaft to protect tractor and tiller drive system
- New super alloy tungsten carbide coated tines, with normal life 3 to 4 times longer over standard heat treated tines
- Gearbox supported by full length tubes for added support
- Large, oil bath, long wearing rotor bearings
- Side mounted skids for depth control
- 16" Dia. x ¼" wall steel tubing roller with adjustable mud scraper
- Turnbuckle height adjustment to obtain exact compaction required
- Roller is 6" wider than side plates to eliminate ridges
- 4 Tailboard turnbuckles to hold the tailboard in place for releasing the exact amount of soil to the roller

NOTE: Other widths available

MODEL S255RR-CT



**CAT II
A. S. A. E.
QUICK
HITCH
COMPATIBLE**



**Levels, Rolls & Lightly
Firms Orchard Floor**



**Cleaned, Tilled & Rolled
Orchard Floor**

MODEL #	TILLING WIDTH	ROLLER WIDTH	NO. OF TINES	APPROX. H.P.	WT.
S205RR-CT	6' - 11" (83")	7' - 11" (95")	48	50 - 70 H.P.	2,290#
S230RR-CT	7' - 8" (92")	8' - 8" (104")	54	60 - 80 H.P.	2,500#
S255RR-CT	8 ½' (102")	9 ½' (114")	60	70 - 90 H.P.	2,850#

Rotary Tillers w/Rollers "T" INCORPORATORS

For year round floor maintenance



An important application for these tillers with rear rollers is to bury wood chips by tilling 2 to 3 inches deep. The roller then slightly compacts and smooths out the orchard floor. The wood chips will decompose at a faster rate and the rolled out area is then in better condition for the harvesters. The University of California Cooperative Extension recommended keeping wood chips and shreadings in the orchards. They also stated that if well managed, prunings can become a source of organic matter and nutrients in the soil. Growers have found many more uses for the Incorporators. Such as - tilling out tire tracks, mulching in weeds and general floor maintenance.

REAR ROLLER FEATURES:

- 18" Diameter x ¼" thick wall steel tubing roller with adjustable mud scraper
- Turnbuckle roller adjustment to obtain exact required compaction with no tools needed
- Easy to bolt up to standard T tiller
- Roller is 6" wider than side plates to eliminate ridges
- 2" Diameter solid bearing shaft
- ½" Thick bolt-on plates between tiller and tailboard to contain soil
- 4 Tailboard turnbuckles to hold the tailboard in place for releasing the exact amount of soil to the roller
- Heavy 1" x 3" roller mounting brackets

See page 83 for "T" tiller specifications.

FEATURES: SPECIAL TINES

- Super alloy coated tungsten carbide
- Coating bonded on areas of normal wear
- Guaranteed to double the life of standard heat treated tines
- In some soils the life can be 3 to 4 times longer wearing



NOTE: Other widths available



T Tiller with Full Width Top Mast



Cleaned, Tilled, and Rolled Orchard Floor

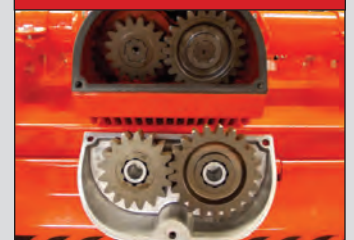

Quick change speeds on 4 Speed Gearbox

MODEL #	TILLING WIDTH	ROLLER WIDTH	ROLLER DIAMETER	NO. OF TINES	MINIMUM HORSEPOWER	WT.
T305RR-CT	10' (120")	11' (132")	18"	72	90	3,375#
T355RR-CT	11'-8" (140")	12'-8" (152")	18"	84	100	4,080#

SPADERS

For deep tilling hard ground

NEW



The **Series VM Medium Duty Spaders** feature a 3 speed gearbox with lever to quickly shift to different speeds. The gearbox has speeds of 145, 166 & 191 R.P.M. These Spaders are a vertical tillage implement, as the spades dig straight down and then turns the soil. The ground is then aerated to an approximate depth of 12 inches. Spaders are a very effective tool for deep digging hard soils without intermixing subsoil with the top soil. The Spaders produce loose texture soil that holds moisture and reduces erosion. Spaders are the ideal implement for farms, vineyards, orchards, etc.

FEATURES:

- Cat. I, 3-point hitch, 540 R.P.M.
- 3 speeds gearbox
- Gearbox can be set for speeds of 145, 166 or 191 R.P.M.
- Gearbox maximum horsepower 60
- Spading depth of 12 inches
- Steel side plates to contain the soil
- Adjustable skids for setting the depth
- Adjustable rear tailboard
- Class 5 driveshaft with slip clutch
- Parking stand

MODEL #	SPADING WIDTH	OVERALL WIDTH	NO. OF SPADERS	MAX. H.P.	WT.
VM6 135	52"	60"	6	60	1,000#
VM6 170	66"	74"	8	60	1,250#

Smaller & larger model available on request



Optional 4 Blade Shown



FEATURES:

- 5' - 28" diameter saw blades
- Cuts branches from 2" to 6" in diameter
- Cutting length is 8 ½ feet
- Two hydraulic cylinders - one for in & out; one for tilt
- One piston pump to operate cylinder
- Saw blades turn at a maximum of 2,600 R.P.M.
- The body of the saw blades is made of rust proof anodized material which is lightweight but stronger than steel
- Equipped with universal hydraulic block for limiting the cutting rotation speed of the blades
- Special centralized greasing system to each saw blade bearing
- Counter weight
- 3-Point hitch, 540 R.P.M. power pack produces 23.8 G.P.M.
- Includes electric controls distributor, control box, 16 feet of electric cable, and JIC fittings
- Tractor mounting bracket must be custom built
- Optional SSL quick attach mount

The **L.E.M.® Sawhead** module was designed for mounting to many different types of equipment such as: tractors with front loaders, skid steer tractors, compact excavators etc. This Sawhead comes with a heavy 4" square beam for mounting. The body of the Sawhead is made of rust proof anodized material which is lightweight, but stronger than steel. This housing module will not deform.

ORDER CODE:	MODEL #	DESCRIPTION	CAPACITY	CUT LENGTH	WT.
5600.4021	LEM7041	Sawblade, 5 Blades	6' max.	8.5 Feet	710#

Built By:  **COLLARD**

1 1/2 TON REAR DUMP



2 1/2 TON REAR DUMP



4 TON 3-WAY DUMP



5 TON 3-WAY DUMP



8 TON REAR DUMP



Our Gearmore **Dump Trailers** offer 5 sizes and capacities to choose from, in rear and 3-way dump. We offer models in single and tandem axle with rear hinged tailgates on all models for ease in dumping. All our models offer foldaway tongue jacks and swivel clevis type hitches. Any user who needs to "haul and dump" will find these trailers save time and money. Some of the popular uses are golf courses, parks, cemeteries, landscapers, growers and ranchers.

OPTION:

~ Central door with adjustable gate for 5 & 8 ton trailers

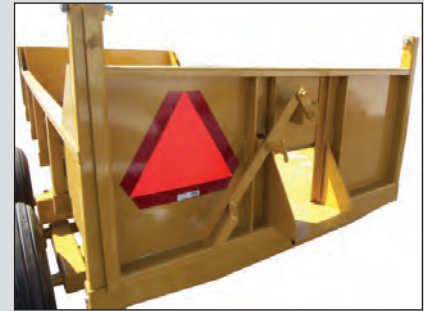

MODEL:	1.5-DT-XB	2.5T60X96	4T63X99	5T63X99	8T60X120
Cap. Wt:	1.5 Ton	2.5 Ton	4 Ton	5 Ton	8 Ton
Capacity:	35 cu. ft.	77 cu. ft.	2.5 cu.yd.	2.5 cu.yd.	3.5 cu.yd.
Tire Size:	18x9.5-8	23x10.5-12	11L x 15	11L x 15	11L x 15
# of Tires:	4	4	2	4	4
Weight:	850#	1,500#	1,825#	1,900#	2,060#
Bed Width:	50"	60"	63"	63"	60"
Bed Length:	70"	94"	99"	99"	120"
Bed Height:	21"	30"	33"	33"	31"
Bed Floor:	12 Gs.	3/16" Plate	3/16" Plate	3/16" Plate	3/16" Plate
Overall Width:	54"	64"	68"	66"	88"
Overall Length:	8' 6"	11' 8"	11' 6"	11' 6"	13' 8"
Overall Height:	34"	52"	61"	61"	61"
Dump Angle:	45°	45°	45°	45°	45°
Side Panels:	13" High	14" High	14" High	14" High	16" High
Rear Panel:	14" High	19" High	18" High	18" High	24" High
Front Panel:	13" High	19" High	18" High	18" High	24" High



COLLARD designed the first vine trimmers, and continues to be the World leader in trimmers. The heart of **COLLARD Trimmers** is the unique lightweight aluminum alloy element that provides a rugged, rust proof framework for the cutting blades.

The P2200 Series are the most popular models as they trim two half rows. Some of these models have the added feature of adjustable bottom skirting blades, which ensures under row vegetation is cut perfectly. Other models are available for trimming half rows, one complete row and two complete rows. Our trimmers eliminate excess vine growth, open canopies for better air circulation and greatly improve spray and dust penetration.

FEATURES - P2200S:

- Heavy duty forklift style frame
- Trims two half rows
- Frame cutting blades adjustable from 4' to 9'
- Equipped with electro-hydraulic joystick controls for precise trimmer adjustment
- Strong, but lightweight and easy to operate
- Vertical breakaway system to protect trimmer and tractor
- High speed stainless steel blades
- Adjustable angle motor driven skirts
- Blades turn at 2,200 R.P.M. ensures clean cane ends which dry and seals neatly to reduce the risk of disease
- Requires hyd. capacity of 5.2 G.P.M. at 2,200 PSI
- Machines have a wide range of adjustments for setting trimmers to operator's exact requirements
- Trimmers have both mechanical and hydraulic protection on side and topping blade assemblies
- Hydraulic cylinders are fitted with load/hold check valves for safety in case a hose fails
- Trimmers come with all hoses, fittings and JIC couplers
- Other models are available for half row, one complete row, and two complete rows - split frame trimmer is available for terraced vineyard
- Front mountings are available for most popular tractors

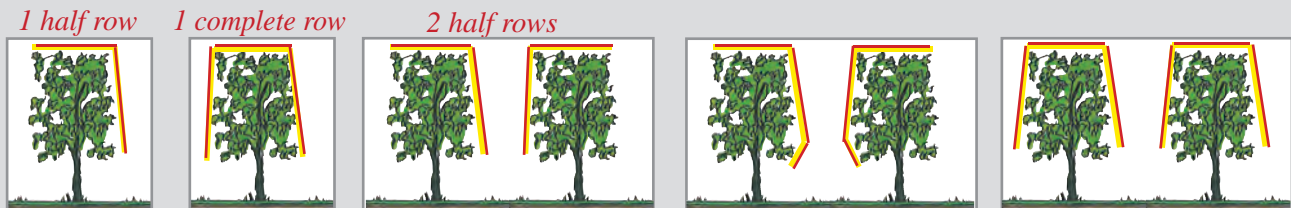

MODEL #	DESCRIPTION	WIDTH ADJUSTMENT	CUTTING HEIGHT	CUTTING TOPS	WT.
P2200S	Trimmer with Skirts	49" to 108"	63"	30.7"	790#

Built By:



Patented Stainless Steel Blades

VINE TRIMMERS

For Vineyards
Complete range of vine trimmers



Model P1100
Trims Half Rows



Model P3000 LZP
Trims 1 Complete Row



Model P2200
Trims 2 Half Rows



Model P2200S
Trims 2 Half Rows, Plus Skirts



Model P2200TS
Trims 2 Half Rows, Terraced Vineyard



Model P3200X
Trims 2 complete Rows

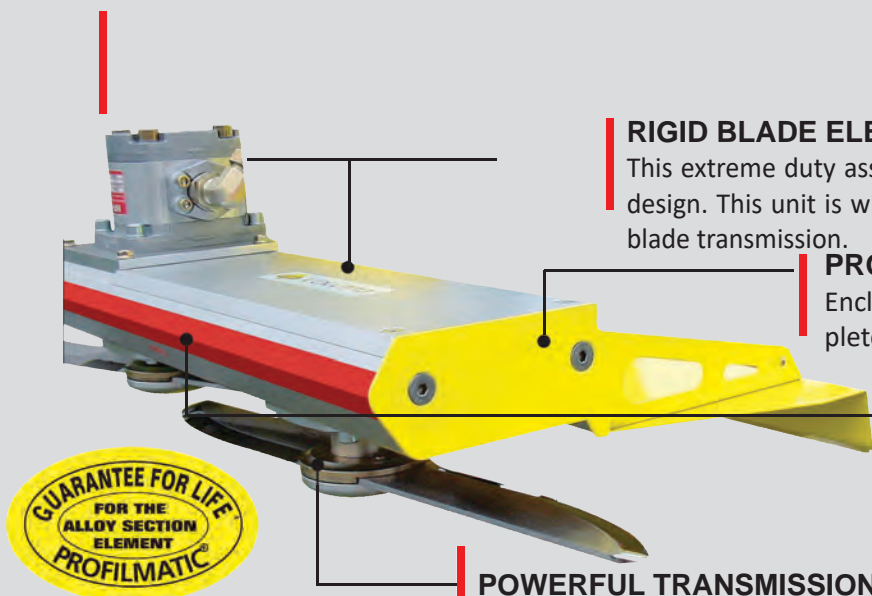

RIGID BLADE ELEMENT (COLLARD patent)

This extreme duty assembly is nearly indestructible due to the unique design. This unit is without equal and guarantees the reliability of the blade transmission.

PROTECTED TRANSMISSION

Enclosed by a special cover, the transmission is completely protected against debris, dust, rain, etc.

SHOCK ABSORPTION

The leading edge of this section is made of synthetic material, it absorbs possible shocks, recessed screws of connection between the modules, ensures a smoother profile which facilitates the smooth evacuation of cut material.

POWERFUL TRANSMISSION

The **PROFILMATIC**[®] is even more powerful, ensuring a very high working speed yet reducing the required power input.



Built By:





P2200 SERIES

Special Collard hydraulic adjustable parallelgram linkage, which provides many advantages.

1. Low position linkage provides excellent operator visibility.
2. Allows for hydraulically adjustment of each side of two half row separately.
3. Effective for both flat land or terraced vineyards.
4. Linkage cylinders and hydraulics are protected in a low position metal box with easy access.

Our trimmers eliminate excess vine growth, open canopies for better air circulation and greatly improve spray and sulfur dust penetration.

FEATURES:

- Trims two half rows
- Frame cutting blades adjustable from 4' to 9'
- Equipped with electro-hydraulic joystick controls for precise trimmer adjustment
- Vertical breakaway system to protect trimmer and tractor
- High speed stainless steel blades, self cleaning
- Blades turn at 2,200 R.P.M. ensures clean cane ends which dry and seals neatly to reduce the risk of disease
- Requires hyd. capacity of 5.2 G.P.M. at 2200 PSI
- Machines have a wide range of adjustments for setting trimmers to operator's exact requirements
- Trimmers have both mechanical and hydraulic protection on side and topping blade assemblies
- Hydraulic cylinders are fitted with load, hold check valves for safety in case a hose fails
- Trimmers come with all hoses, fitting and JIC couplers
- Option: Skirters

MODEL #	DESCRIPTION	WIDTH ADJUSTMENT	CUTTING HEIGHT	CUTTING TOPS	WT.
P2200X	Trimmer 2 Half Rows	49" to 108"	63"	30.7"	790#

LEAF REMOVERS Front Mounted - Value Model

Unique leaf removal system



The Leaf Remover with double flow of low pressure air, produced by the compressor, blows through the leaves by dual rotating nozzles that remove the leaves on both the outside and the interior of the row; achieving selective leaf removal around the grape clusters. Only this technology makes it possible to “leaf” from falling flower heads to the harvest.

The Leaf Remover exposes the clusters to air and sunlight and improves spray penetration. We are able to give all the results like handwork at a fraction of the cost per acre.

Built By:  **COLLARD**

FEATURES: Front Mounted Defoliation Head

- **ELLIPSE-MULTIROTOR** dual rotor defoliation head - “patented”
- Reinforced pivot system for 180° right to left position
- Adjustment system of defoliation head for positioning horizontal to vertical and in between
- Easily choose between two nozzle diameters with the selective system
- Electric oil flow regulator to adjust the nozzles rotation speed
- One defoliating head with “patented” twin rotors
- Defoliation head is hydraulically controlled allowing for rotating to right or left side of rows
- Head turns for adjusting air diameter from 11 to 23.5 inches at fruit zone
- Defoliation head hydraulic adjust out from 26" to 38" from the center line of the tractor

- Electric controls distributor with joystick
- The stainless steel covered head is effective up to 6 inches away from clusters
- Hydraulic adjustments are: up/down, in/out and right/left

FEATURES: Rear Mounted Air Compressor

- 3-point hitch mounted air compressor
- Cat. I & II hitch, 540 R.P.M. PTO
- Compressor is fitted with special prefiltration and ventilation kit
- Compressor silencer is equipped with a filter
- The leaf remover comes with all hoses, fittings, and JIC couplers
- Reflective safety signs

ORDER CODE	MODEL #	DESCRIPTION	HYD. REQ'D	PRESSURE	MINIMUM HORSE-POWER	WEIGHT HEAD ASSY.	COM-PRESSOR WT.
04112020	E1100FR NX2	Leaf Remover	7 - 13 G.P.M.	2,320	35 H.P.	755#	630#



Our "State of the Art" **Leaf Remover** has new design features which allow for operating in many different trellis systems.

The COLLARD with double flow of low pressure air, produced by the compressor, blows through the leaves by dual rotating nozzles that remove the leaves on both the outside and the interior of the row; achieving selective leaf removal around the grape clusters. Only this technology makes it possible to "leaf" from falling flower heads to the harvest.

FEATURES:

- **ELLIPSE-MULTIROTOR** dual rotor defoliation head - "patented"
- Reinforced pivot system for 180° right to left position
- Electric oil flow regulator to adjust the nozzles rotation speed
- Narrower defoliation head for better penetration into the vegetation
- Adjustment system of defoliation head for positioning horizontal to vertical & in between
- Chassis designed to extend the arm supporting the head horizontally to avoid branch damage
- The defoliation heads are completely adjustable to any angle required
- 3-Pt. hitch mounted air compressor, PTO driven
- Compressor is fitted with special prefiltration and ventilation kit
- Electric control distributor with ergonomic handle
- Hydraulic adjustment with three cylinders:
 - 1 - up/down independent of defoliation head
 - 1 - in/out independent of defoliation head
 - 1 - pivot
- The stainless steel covered head is effective up to 6 inches away from clusters

Why Deleaf?

- primary reason is to obtain better air flow
- increase light penetration in fruit zone
- aids in ripening the grapes
- reduces the chance of powdery mildew

FEATURES: AIR COMPRESSOR

- Cat. I & II, 3-point hitch
- Bottom hitch pins are adjustable in and out
- 540 R.P.M., PTO driven air compressor now standard with NX5 compressor achieving more pressure at lower R.P.M.
- Compressor is fitted with special prefiltration and ventilation kit
- Gearbox to increase speed
- Two separate chambers one for air and one for oil
- 3 safety reflective signs
- Heavy skid bottom runners

Built By:



ORDER CODE	MODEL #	DESCRIPTION	HYDRAULIC REQUIREMENTS	PRESSURE	MINIMUM HORSEPOWER	WT.
04110350	E1100FR.V3	Leaf Remover	8 G.P.M.	2,400	60 H.P.	1,300#

LEAF REMOVERS Unique Leaf Removal System

Deleafs 2 1/2 rows



These **Leaf Removers** feature Ellipse-Multirotor dual rotor defoliation heads "patented". The double flow of low pressure air blows through the leaves on both the outside and interior of the rows achieving selective leaf removal around the grape clusters. This rapid pulsing air literally shatters the leaves from the foliage and rattles the caps free from the berries. Our leaf removal system is so effective that it can be used through the whole season from before flowering to harvest.

The COLLARD exposes the clusters to air and sunlight and improves spray penetration. We are able to give all the results like handwork at a fraction of the cost per acre.

Why Deleaf?

- primary reason is to obtain better air flow
- increase light penetration in fruit zone
- aids in ripening the grapes
- reduces the chance of powdery mildew

FEATURES:

- Rapid pulses of low pressure (15 PSI) air shatters the leaves from the foliage
- Electric oil flow regulator to adjust the nozzles rotation speed
- **ELLIPSE-MULTIROTOR**® dual rotor defoliation head - "patented"
- Narrower defoliation head for better penetration into the vegetation
- Adjustment system of defoliation head for positioning horizontal to vertical & in between
- Hydraulic adjustment with four cylinders:
 - 2 - up/down independent of defoliation head
 - 2 - in/out independent of defoliation head
- The stainless steel covered head is effective up to 6 inches away from clusters
- Comes with heavy shipping/storage stand

FEATURES: AIR COMPRESSOR

- Cat. I & II, 3-point hitch
- 540 R.P.M., PTO driven air compressor
- The NX5 air compressor is standard
- The "new" NX8 air compressor produces more air for better penetration and allows for faster tractor speeds
- Bottom hitch pins are adjustable in and out
- Compressor is fitted with special prefiltration and ventilation kit
- Gearbox to increase speed
- Two separate chambers one for air and one for oil
- 3 safety reflective signs
- Heavy skid bottom runners

Built By:



ORDER CODE	MODEL #	NO. OF HEADS	NO. OF OPERATING NOZZLES	COMPRESSOR MODEL #	MINIMUM HORSEPOWER	WT.
04224560	E2200F	2	2	NX5	60 H.P.	1,600#
04224570	E2200F MAX	2	4	NX8	80 H.P.	2,000#

PCI3000 Box

The **COLLARD Box Prepruners** were developed for pruning in "High Wire" vineyards. These Box Prepruners are very versatile as the four hydraulic cylinders operate up/down, in/out, and tilt 10° right and left. The operator has full adjustment control with a handy joystick. The one complete row unit features three aluminum cutting housings with each having two 17.7", 236 teeth saw blades. The heavy duty single post main beam allows for easy mounting to the front of tractors.

Also, available are two row prepruners for custom mounting to harvesters and other vehicles.



ORDER CODE	MODEL #	DESCRIPTION	MOUNT TYPE	WT.
0180 0150	PCI3000 BOX	Box Prepruner, One Complete Row	Tractor	1,050#
0180 0100	PCE3200 BOX	Box Prepruner, Two Complete Rows, for custom mounting (no center mast)	Custom	500#

FEATURES:

- Designed to prune one complete row
- Three 15cc hydraulic motors to power the saw blades
- Cane cutting heights are hydraulic adjustable from 47" to 86"
- Three hydraulic cylinders - one for up/down, one for in/out, and one for tilting 10° right and left
- Cylinders are fitted with anti-fall safety valves
- Hydraulics controlled with joystick
- The three aluminum cutting housings each have two 17.7" (450mm) 236 teeth saw blades
- Tractor hydraulic requirement of at least 10.5 G.P.M. at 2,600 PSI
- Prepruners come with storage stand
- Custom built brackets are required for mounting to front of tractors

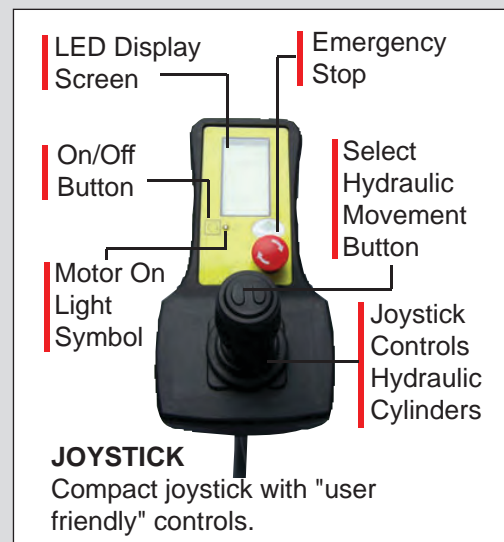

PREPRUNERS

For Vineyards
To reduce the cost of hand pruning

PCI3000LPR SERIES



The **COLLARD Prepruners** will greatly reduce your pruning costs. Growers state that the finish hand pruning takes only 25% of the time versus total hand pruning costs. The Prepruner cuts the long canes small enough that they fall through the wire which is an aid in clean-up.

The Prepruner features a dual system for opening and closing of the cutting heads, **UNIQUE MAGNETIC SENSORS** and manual hand lever.

These front mounted Prepruners for vertical trellis vine grapes are low maintenance and high production giving the COLLARD units high marks with several leading California growers.

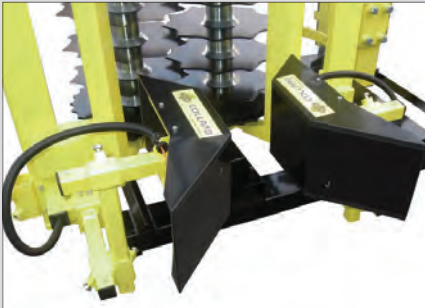

Magnetic sensors - Open and close cutting heads when sensing steel posts



Cutting blades and notched discs for clean cuts and trellis post protection

FEATURES:

- Heavy front mount frame for mounting to tractor
- Cane cutting length of 28.1"
- Dual hydraulic motors to power the cutting blades
- Three hydraulic cylinders - one for up and down, one stroke cylinder for in and out and one stroke cylinder for cross slope
- Cylinders are fitted with anti-fall safety valves
- Simple spring system to adjust the blade pressure
- Comes with heavy duty shipping/storage stand
- Tractor requirements of at least 6.6 G.P.M. at 2,030 PSI
- Custom built brackets are required for tractors and harvesters

ORDER CODE	CUTTING LENGTH	SPACE BETWEEN BLADES	NO. BETWEEN BLADES	WT.
0178 3502 1715	28.1"	4.3"	7 per side	1,160#

Also available with manual retraction only

Built By: 

Stump Grinders



Economical and efficient PTO powered **Stump Grinders** make stump removal fast and easy. Operator easily controls the grinder from the comfort of the tractor seat. Surefoot™ stabilizer provides secure footing during operation.

- SG-26 designed for tractors 22-50 PTO H.P.; SG-36 designed for tractors 45-100 H.P.
- Easy to operate - hydraulic controls allows easy operation from the seat of the tractor
- Durable carbide - tipped cutting teeth are economical and easy to replace
- 2 Pair of remote hydraulic outlets are required on tractor

Grader Blades



This patented **SSGB-8B Grader** was designed to be used by asphalt, landscape and concrete contractors. The grader has a wide 8', 6-way hydraulically controlled moldboard operated by in-cab remote controls.

- Long main beam w/caster wheels & 18.5" x 8.5" tires
- 15" high moldboard with double bevel cutting edges, shear pin protected
- Moldboard rotation left & right, tilt up and down all up to 25°
- Pair of removable end plates

Concrete Mixers



Worksaver's **Skid Steer Mount Mixer**, Model SS-590 has direct hydraulic drive. This eliminates chain and sprocket maintenance resulting in more up time on the job-site. Featuring all welded steel drum with internal paddles.

- 11 cu. ft. drum with mixing capacity of 5 cu. ft. of concrete (1 bag mix)
- Flow control valve for easy on-off operation
- Includes hoses with flat faced couplers
- Long based removable parking stands

Post Drivers



These hydraulically operated **Post Drivers** are available in 3-point hitch, loader mount, skid steer mount and in manual or hydraulic adjustment. Maximum post size of 8 3/4" diameter by 10' long.

- Designed to do both wood and steel posts
- Impact at full stroke is 80,000 pounds
- Spring loaded arm holds posts securely for "hands free" operation
- Transport pin secures units for travel and storage

Built By:

WORKSAVER

Gearmore is committed to providing the finest, most reliable, time and labor saving equipment, at the right price to help the bottom line of any business.



13477 Benson Ave. Chino, CA 91710
Ph: 909/548-4848 sales@gearmore.com
www.gearmore.com