

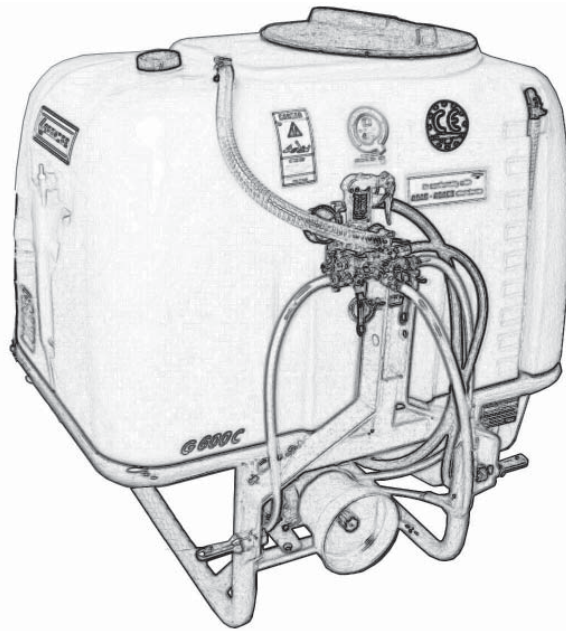

# ECONOMY SPRAYERS GC SERIES



**Parts Manual  
For Models:  
GC400 & GC600**

Rev. September 2014

# TABLE OF CONTENTS

<u>SECTION</u>	<u>DESCRIPTION</u> .....	<u>PAGE</u>
<b>1</b>	<b>Introduction</b> .....	<b>1</b>
1.1	Purchaser's Responsibility .....	1
1.2	Serial Number Information .....	1
<b>2</b>	<b>Replacement Parts</b> .....	<b>2 - 10</b>
2.1	GC400 Main Frame & Tank .....	2
2.2	GC400 Parts List .....	3-4
2.3	GC600 Main Frame & Tank .....	5
2.4	GC600 Parts List .....	6-7
2.5	Run of Fluids .....	8
2.6	Parts List .....	9-10
<b>3</b>	<b>Limited Warranty</b> .....	<b>9</b>

# 1 INTRODUCTION

This manual contains parts diagrams and replacement parts lists. Do not modify the equipment in any way. Unauthorized modification may impair the function and/or safety and could affect the life of the equipment.

It is the responsibility of the owner to make sure the machine is maintained properly, and that all parts are in working order.

Where replacement parts are necessary for periodic maintenance and servicing, genuine factory replacement parts ***MUST*** be used to restore your equipment to original specifications. The manufacturer will not be responsible for injuries or damages caused by use of unapproved parts and/or accessories.

The manufacturer reserves the right to make improvements to the machinery and parts at any time and at their discretion.

**OPERATOR ORIENTATION** - The directions left, right, front and rear, are as seen from the driver's seat and facing in the direction of travel.

## 1.1 PURCHASER'S RESPONSIBILITY

It is the responsibility of the purchaser and/or operator to.....

- Inspect the equipment and replace or repair any parts that are damaged or worn which under continued operation would cause damage, wear to other parts, or cause a safety hazard.
- Return the equipment or parts to the authorized dealer, from where it was purchased, for service or replacement of defective parts that are covered by warranty. (The factory may inspect equipment or parts before warranty claims are honored.)
- Payment of all costs incurred by the dealer for traveling to or transporting the equipment for warranty inspection and or claims.

## 1.2 MODEL / SERIAL NUMBER

NAME: \_\_\_\_\_

PURCHASED FROM: \_\_\_\_\_

DATE OF PURCHASE: \_\_\_\_\_

MODEL NUMBER: \_\_\_\_\_

SERIAL NUMBER: \_\_\_\_\_

# 2 REPLACEMENT PARTS

## 2.1 GC400 MAIN FRAME & TANK

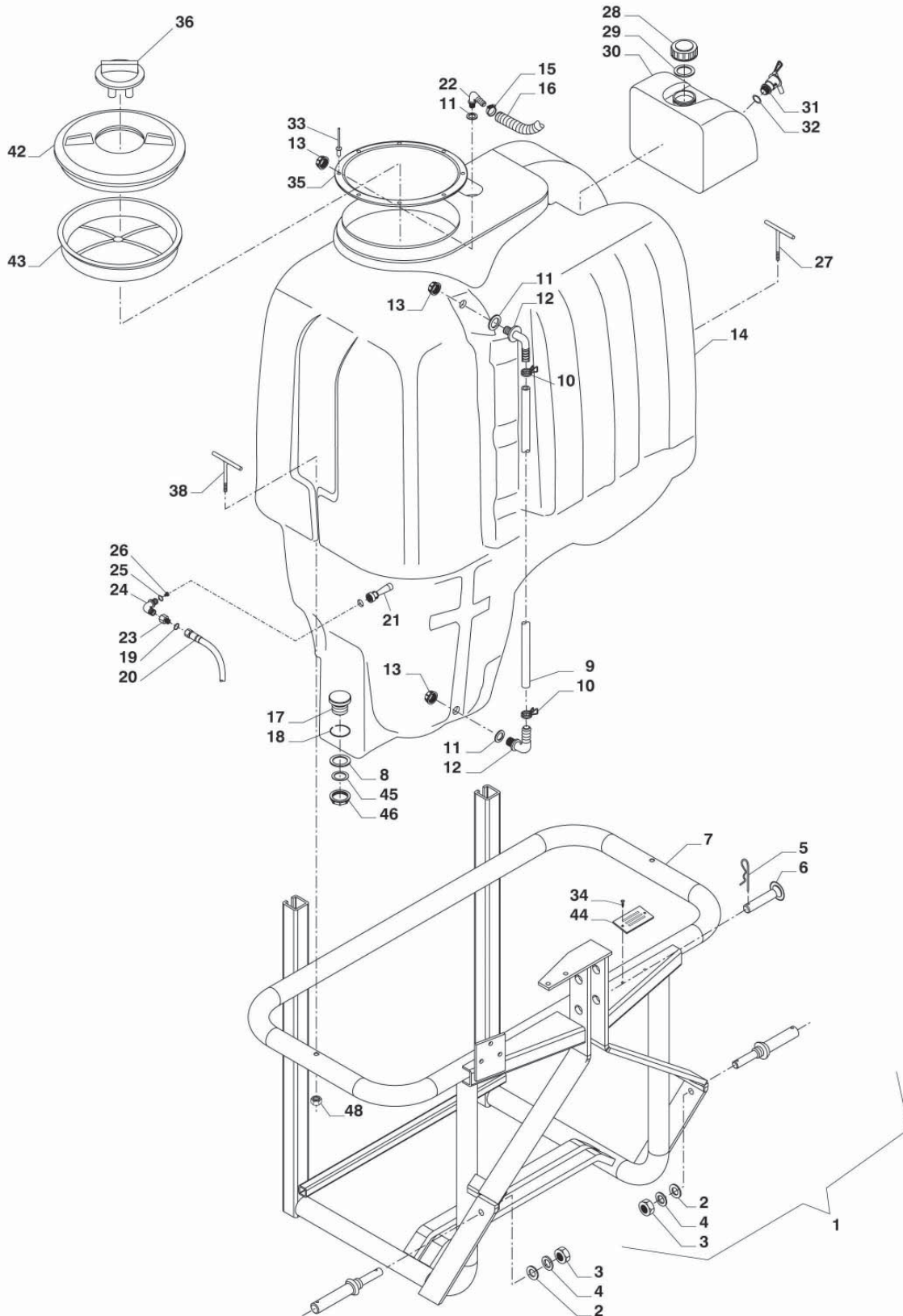

## 2 REPLACEMENT PARTS (CONTINUED)

### 2.1 GC400 MAIN FRAME & TANK (Continued)

<u>REF.</u>	<u>QTY.</u>	<u>PART NO.</u>	<u>DESCRIPTION</u>
1	2	2100011	Single Complete Pivot 22-22
2	2	1800168	Washer 23 x 39 UNI 6592 R 40 Galvanized
3	2	0102292	Nut M.22 x 1.5 PF Galvanized
4	2	1800167	Washer Grower D.23 x 35 UNI L. 1751 Galvanized
5	1	2100001	Pin R 3
6	1	0102244	Pin D.19
7	1	0102021	Frame GC400
8	1	AG2052050	Lock Ring G 1 1/4
9	1	1600571	Vipla Crystal Hose 12 x 17 L=750
10	2	1500030	Clamp BIF. A Spring 173 mm 16.8-17.7
11	3	1700001	Gasket D.32 x 21 x 2
12	2	1400130	Elbow Fitting D.13 1/2
13	3	1400001	Ring Nut 1/2
14	1	0600273	Tank Minnesota ATOM 400 LT NAT L
15	1	1500003	Clamp Perfect 14 x 27
16	1	1600209	Tube Spiral D.20 L=650
17	1	1400017	Outlet
18	1	1700015	Gasket 57.5 x 40 x 3
19	1	AG006100PE	Gasket For Joint D.11.8 x 18 x 2 P
20	1	1600235	Hose CO.PCV 10 x 19 80 Bar L=800
21	1	1400074	Body Jet Agitation
22	1	1400062	Elbow Connector D.20 1/2 G
23	1	1300146	Extension Cylindrical MF 1/2"
24	1	AG502010.020	Welding For Thread
25	1	1700006	OR D.36 x 26 x 5
26	1	1400076	Nozzle D.2
27	1	0600355	Tie Rod 90 x 80 x 100 H120
28	1	0600358	Plug Handwashing Minnesota ATOM D.80 S/Gasket
29	1	0600359	Flat Gasket D.56 x 80 x 2 Handwashing Plug Minnesota ATOM
30	1	0600357	Tank Handwashing Minnesota ATOM NAT.
31	1	0600190	Handwashing Valve
32	1	0600191	Gasket Valve
33	8	1800351	Tear A Rivet D.5 x 20 Aluminum
34	2	1800480	Rivet TT AL 3 x 10
35	1	0600014	Tank Ring
36	1	AG3522000	Group Double Valve
38	1	0600356	Tie Rod 90 x 80 x 100
42	1	AG3522060	Tank Lid
43	1	0600023	Tank Filter

## 2 REPLACEMENT PARTS (CONTINUED)

### 2.1 GC400 MAIN FRAME & TANK (Continued)

<u>REF.</u>	<u>QTY.</u>	<u>PART NO.</u>	<u>DESCRIPTION</u>
44	1	2600009	Small Label Register
45	1	1700011	Gasket D.40 x 25 x 4
46	1	1400010	Female Plug 1" 1/4
48	2	1800191	Nut Aut. High M12
49	5	1800011	Bolt TE UNI 5739 8.8 6 x 16 Galvanized
50	5	1800114	Washer 6 x 18 UNI 6593 R40 Galvanized
51	1	E.MATCIR05/600NA	Clean Water Tank ATOM 500/600 NAT 48 LT.
52	1	0600360	Tank Plug D.122 Spring Valve
53	1	0600361	Plug Gasket D.122
54	1	1500008	SS Clamp INOX AISI/304 21 x 38/12.7
55	1	0600356	Tie Rod 90 x 80 x 100 H170

## 2 REPLACEMENT PARTS (CONTINUED)

### 2.2 GC600 MAIN FRAME & TANK

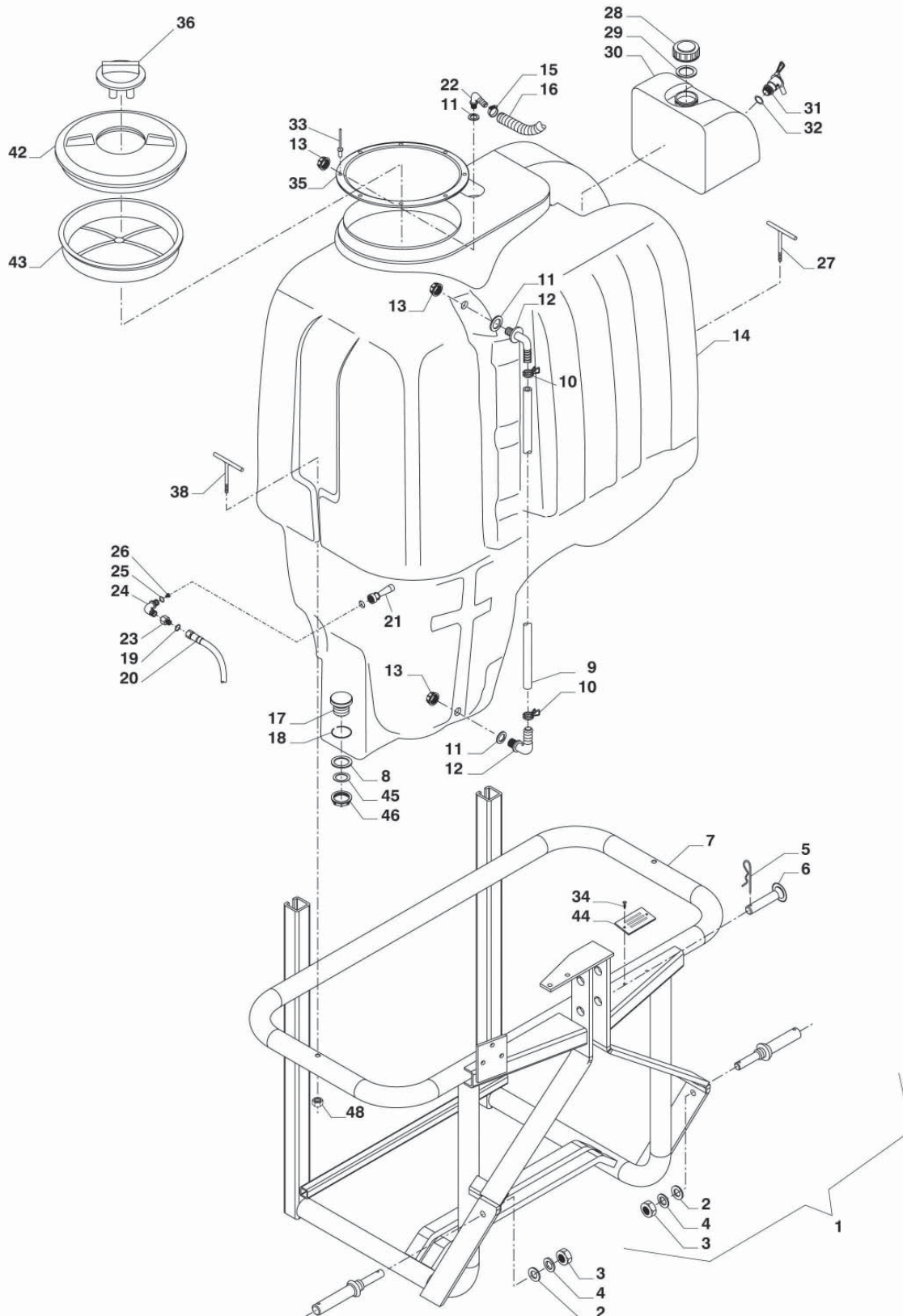

## 2 REPLACEMENT PARTS (CONTINUED)

### 2.2 GC600 MAIN FRAME & TANK (Continued)

<u>REF.</u>	<u>QTY.</u>	<u>PART NO.</u>	<u>DESCRIPTION</u>
1	2	2100011	Single Complete Pivot 22-22
2	2	1800168	Washer 23 x 39 UNI 6592 R 40 Galvanized
3	2	0102292	Nut M.22 x 1.5 PF Galvanized
4	2	1800167	Washer Grower D.23 x 35 UNI L. 1751 Galvanized
5	1	2100001	Pin R 3
6	1	0102244	Pin D.19
7	1	0102026	Frame GC600
8	1	AG2052050	Lock Ring G 1 1/4
9	1	1600883	Vipla Crystal Hose 12 x 17 L=1050
10	2	1500030	Clamp BIF. A Spring 173 mm 16.8-17.7
11	3	1700001	Gasket D.32 x 21 x 2
12	2	1400130	Elbow Fitting D.13 1/2
13	3	1400001	Ring Nut 1/2
14	1	0600272	Tank Minnesota ATOM 600 LT NAT L
15	1	1500003	Clamp Perfect 14 x 27
16	1	1600209	Tube Spiral D.20 L=650
17	1	1400017	Outlet
18	1	1700015	Gasket 57.5 x 40 x 3
19	1	AG006100PE	Gasket For Joint D.11.8 x 18 x 2 P
20	1	1600235	Hose CO.PCV 10 x 19 80 Bar L=800
21	1	1400074	Body Jet Agitation
22	1	1400062	Elbow Connector D.20 1/2 G
23	1	1300146	Extension Cylindrical MF 1/2"
24	1	AG502010.020	Welding For Thread
25	1	1700006	OR D.36 x 26 x 5
26	1	1400076	Nozzle D.2
27	1	0600356	Tie Rod 90 x 80 x 100 H170
28	1	0600358	Plug Handwashing Minnesota ATOM D.80 S/Gasket
29	1	0600359	Flat Gasket D.56 x 80 x 2 Handwashing Plug Minnesota ATOM
30	1	0600357	Tank Handwashing Minnesota ATOM NAT.
31	1	0600190	Handwashing Valve
32	1	0600191	Gasket Valve
33	8	1800351	Tear A Rivet D.5 x 20 Aluminum
34	2	1800480	Rivet TT AL 3 x 10
35	1	0600014	Tank Ring
36	1	AG3522000	Vent Lid
38	1	0600356	Tie Rod 90 x 80 x 100
42	1	AG3522060	Tank Lid (includes AG3522000, Ref. #36 Vent Lid)
43	1	0600023	Tank Filter



## 2 REPLACEMENT PARTS (*CONTINUED*)

### 2.2 GC600 MAIN FRAME & TANK (*Continued*)

<u>REF.</u>	<u>QTY.</u>	<u>PART NO.</u>	<u>DESCRIPTION</u>
44	1	2600009	Small Label Register
45	1	1700011	Gasket D.40 x 25 x 4
46	1	1400010	Female Plug 1" 1/4
48	2	1800191	Nut Aut. High M12
49	5	1800011	Bolt TE UNI 5739 8.8 6 x 16 Galvanized
50	5	1800114	Washer 6 x 18 UNI 6593 R40 Galvanized
51	1	E.MATCIR05/600NA	Clean Water Tank ATOM 500/600 NAT 48 LT.
52	1	0600360	Tank Plug D.122 Spring Valve
53	1	0600361	Plug Gasket D.122
54	1	1500008	SS Clamp INOX AISI/304 21 x 38/12.7
55	1	0600356	Tie Rod 90 x 80 x 100 H170

## 2 REPLACEMENT PARTS (CONTINUED)

### 2.3 PUMP ASSEMBLY

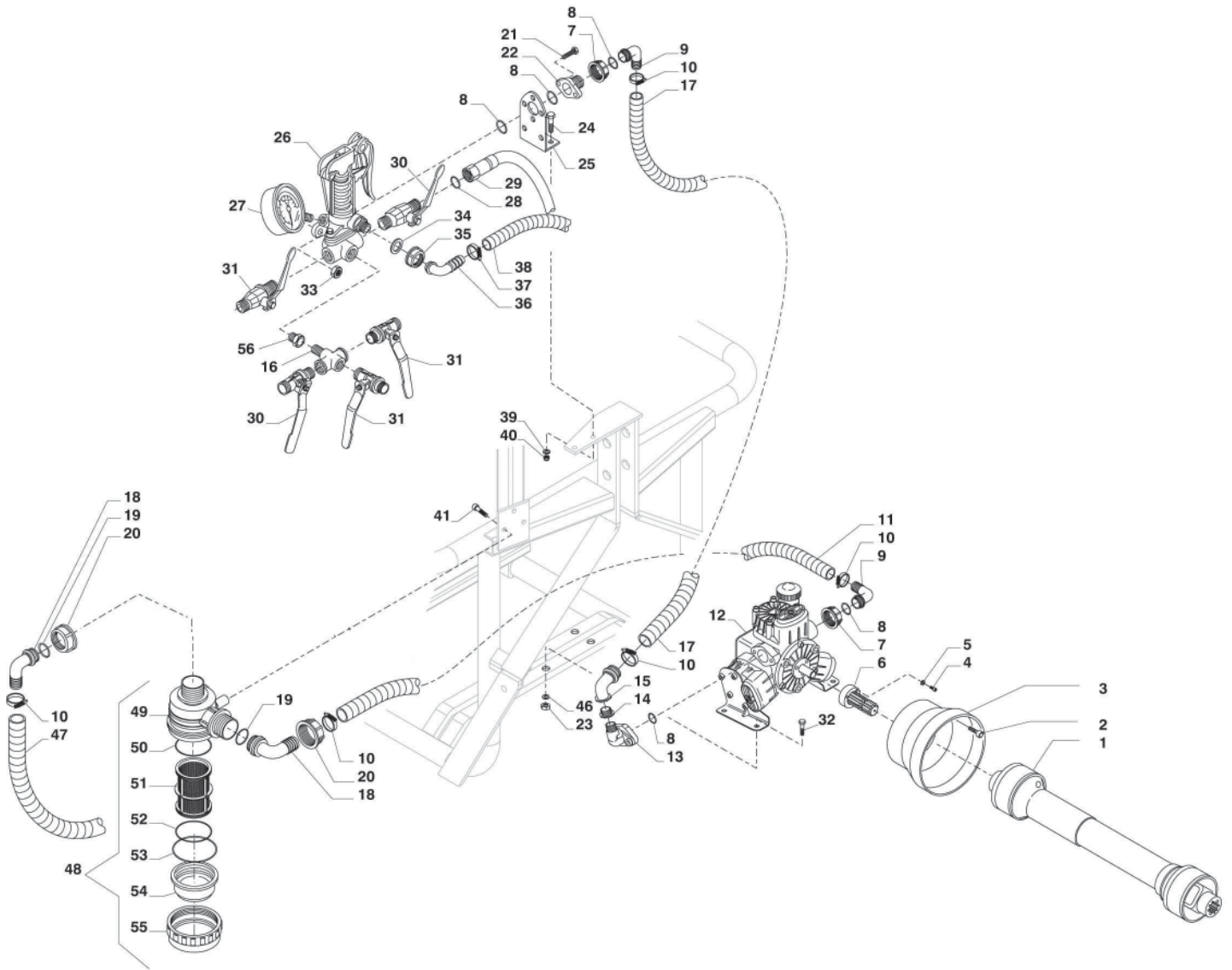

## 2 REPLACEMENT PARTS (CONTINUED)

### 2.3 PUMP ASSEMBLY (Continued)

<u>REF.</u>	<u>QTY.</u>	<u>PART NO.</u>	<u>DESCRIPTION</u>
1	1	0900098	Shaft B1 1000 CE A60 A60
2	4	1800034	Bolt TCEI UNI 5931 8.8 10 x 20 Z
3	1	AR1498	Outlet Side
4	3	1800036	Bolt TE M10 x 25 UNI 5739 8.8 Galvanized
5	3	1800129	Washer Grower UNI 1751 M.10
6	1	AR1519	Cardan Joint "C" AR303
7	1	AR550242	Ring Nut
8	5	AR550350	O-Ring
9	1	AR550370	Elbow
10	4	1500004	Clamp Perfect 21 x 38
11	1	1600692	Spiral Hose D.25 L=1000
12	1	AR460	Pump AR403 SP SGC
13	1	AR450145	Flange
14	1	1300226	Reducer M.F. CIL 449 1/2 1/4
15	1	AG1102325	Curve Adapter 3/4" F. D.25
16	1	AR1041220	Cross Fitting 3/8"
17	1	1600882	Hose 25 x 37 Rotary Drill 20 L=1250
18	2	1400057	Curve Connector D.25
19	2	1700066	OR D.31 x 25 x 3
20	2	1400013	Fly Nut 1" 1/4
21	2	AR160660	Bolt
22	1	AR550390	Flange
23	4	1800186	Nut Aut. HIGH CL. 8 M 10
24	2	1800021	Bolt TE UNI 5739 8.8 8 x 20 Galvanized
25	1	AR320406	Bracket
26	1	AR887	Reg. of Pression GS20 3 Ways
27	1	AR391240	Pressure Gauge D.63 0-24 BAR
28	1	AG006100PE	Gasket For joint D.11.8 x 18 x 2 P
29	1	1600235	Hose CO. PCV 10 x 19 80 BAR L=800
30	2	1300010	Valve LH 3/8" x 1/2" A.5264
31	3	1300009	Cock RH 3/8" x 1/2" "Meteor" A.5263
32	4	1800036	Bolt TE M 10 x 25 UNI 5739 8.8 Galvanized
33	2	1800180	Nut M8 UNI 5587 - 6.8 Galvanized
34	1	AR880830	O-Ring
35	1	AR550450	Ring Nut
36	1	AR550460	Elbow
37	1	1500003	Clamp Perfect 14 x 27
38	1	1600209	Tube Spiral D.20 L=650
39	2	1800120	Flat Washer UNI 6592 M.8 Galvanized

## 2 REPLACEMENT PARTS (CONTINUED)

### 2.3 PUMP ASSEMBLY (Continued)

<u>REF.</u>	<u>QTY.</u>	<u>PART NO.</u>	<u>DESCRIPTION</u>
40	2	1800180	Nut M 8 UNI 5587 - 6.8 Galvanized
41	2	1800020	Bolt TE M8 x 16 UNI 5739 - 8.8 Galvanized
46	4	1800130	Plain Washer UNI 6592 M.10
47	1	1600512	Spiral Hose D.25 L=600
48	1	AG3122053	Filter ASP 1" 1/4 FC 50 M
49	1	AG3102050.010	Filter Body ASP. 1" 1/4
50	1	AG462200.040	OR 2.62 x 58.42 3231 EPDM
51	1	AG3122003.030	Filter
52	1	AG462200.040	OR 2.62 x 58.42 3231 EPDM
53	1	AG454237.090	OR 3.53 x 78.97
54	1	AG3122000.020	Cover Filter
55	1	1400069	Filter Nut
56	1	AR1041210	Adapter 3/8 GAS M-F

# 2 REPLACEMENT PARTS (CONTINUED)

## 2.4 PUMP ASSEMBLY AR403

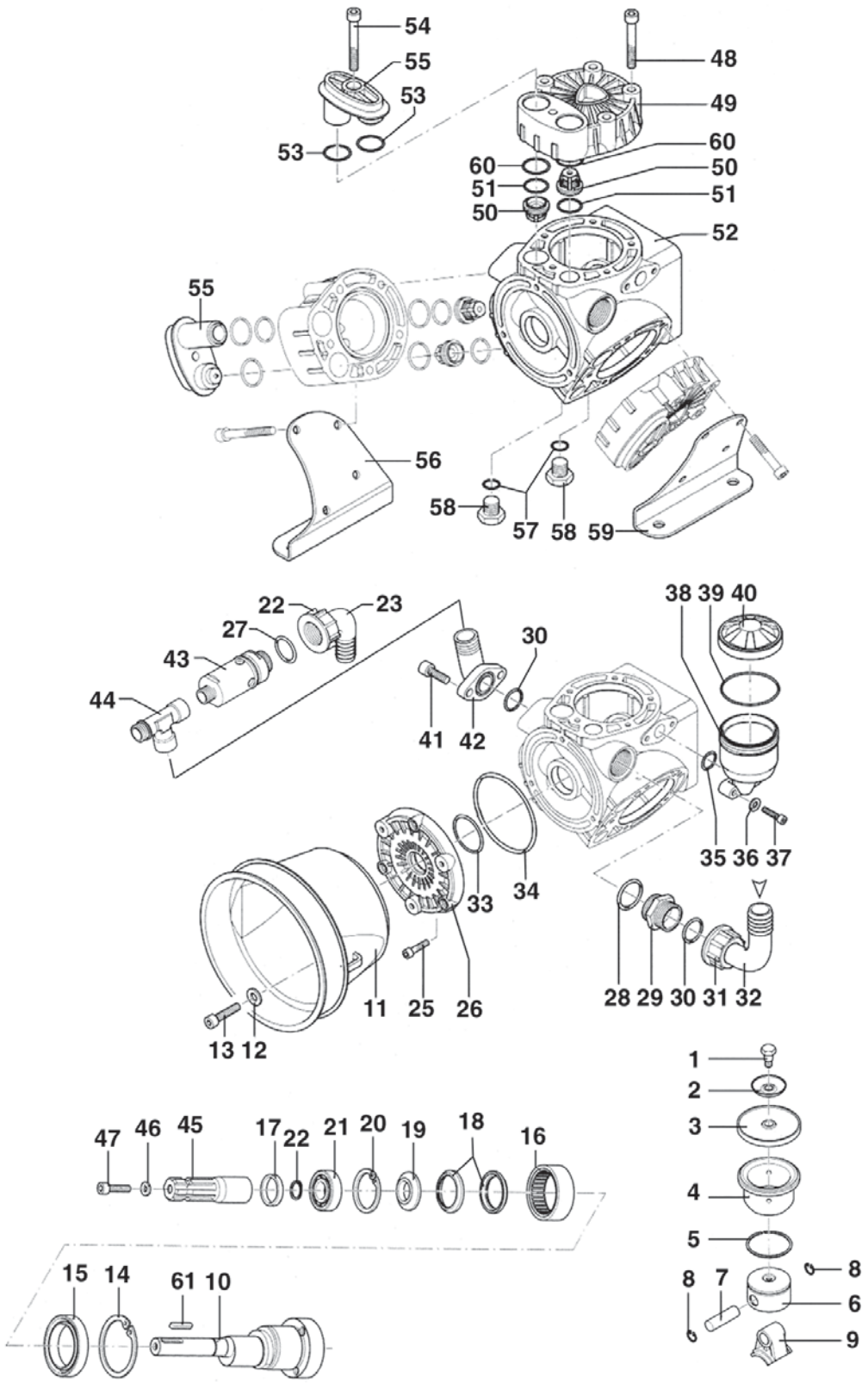

## 2 REPLACEMENT PARTS (CONTINUED)

### 2.4 PUMP ASSEMBLY AR403 (Continued)

<u>REF.</u>	<u>QTY.</u>	<u>PART NO.</u>	<u>DESCRIPTION</u>
1	3	800090	Pin, Diaphragm
2	3	800350	Washer, Cup
3	1	2387	Diaphragm Kit
4	3	1880050	Sleeve
5	3	1880110	Piston Ring
6	3	1880060	Piston
7	3	1880120	Pin, Piston
8	6	380080	Circlip, Piston
9	3	1880070	Rod, Connecting
10	1	1880160	Crankshaft
11	1	1500350	Shield
12	3	380241	Washer D.8.5
13	3	850250	Bolt M10 x 16
14	1	620330	Circlip
15	1	50X65X8	Oil Seal
16	1	DHK5020	Bearing
17	1	1880190	Seal Ring
18	2	1880180	Ring
19	1	1880170	Spacer
20	1	47247	Circlip I47
21	1	1461430	Bearing
22	1	47120	Circlip E20
23	1	550460	Elbow
24	1	550450	Nut
25	3	780060	Bolt M6 x 25
26	1	1880021	Manifold
27	1	880831	O-Ring 15.54 x 2.62
* 28	1	OR293	O-Ring 29 x 3
29	1	550340	Nipple 1"
* 30	2	550350	O-Ring 23.81 x 2.62
31	1	550242	Nut
32	1	550370	Elbow
* 33	1	390201	O-Ring
* 34	1	1880130	O-Ring
* 35	1	OR1872262	O-Ring 18.72 x 2.62
36	2	550331	Washer D.6.5
37	2	1200440	Bolt M6 x 30
38	1	1040310	Tank, Oil
* 39	1	650920	O-Ring

## 2 REPLACEMENT PARTS (CONTINUED)

### 2.4 PUMP ASSEMBLY AR403 (Continued)

<u>REF.</u>	<u>QTY.</u>	<u>PART NO.</u>	<u>DESCRIPTION</u>
40	1	1040320	Cap
41	2	540290	Bolt M8 x 25
42	1	450145	Flange
43	1	1433	Relief Valve
44	1	1620450	Tee
45	1	621370	PTO Adapter
46	1	961340	Washer
47	1	680350	Bolt M8 x 35
48	1	800860	Bolt M8 x 55
49	3	1880030	Head
50	1	2388	Check Valve Kit (with O-Rings Ref. #51)
*51	9	1140450	O-Ring 20.24 x 2.62
52	1	1880010	Housing
*53	6	OR2670178	O-Ring 26.7 x 1.78
54	3	280080	Bolt M8 x 60
55	3	1880040	Cover
56	1	1880090	Bracket L.H.
*57	2	OR14178	O-Ring 14.1 x 1.78
58	2	880530	Plug
59	1	1880080	Bracket R.H.
60	6	780050	O-Ring 28.25 x 1.78
61	1	620680	Tempered Key 6 x 6 x 30

<b>* KIT 2389</b>		
<b>Ref.</b>	<b>Part No.</b>	<b>Qty.</b>
28	OR293	1
30	550350	2
33	390201	1
34	1880130	1
35	OR1872262	1
39	650920	1
51	1140450	9
53	OR2670178	6
57	OR14178	2

## 2 REPLACEMENT PARTS (CONTINUED)

### 2.5 VALVE ASSEMBLY GS40

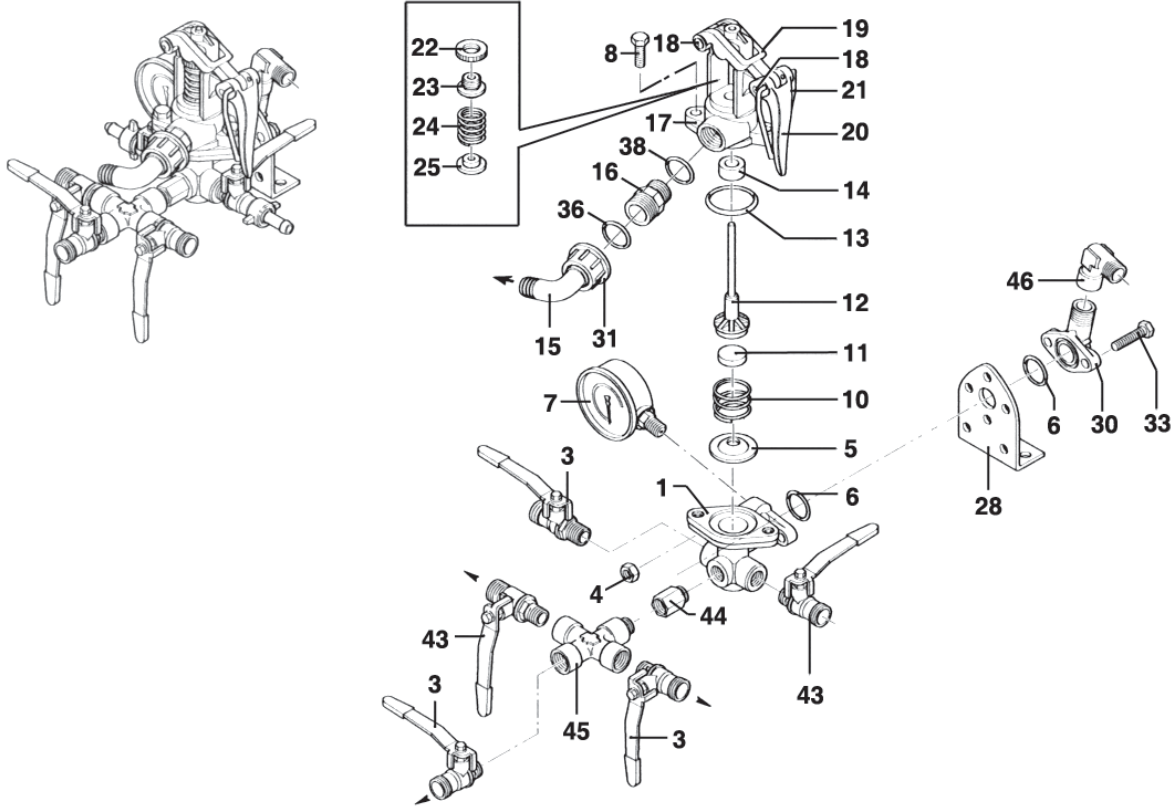

<u>REF.</u>	<u>QTY.</u>	<u>PART NO.</u>	<u>DESCRIPTION</u>
1	1	620220	Body, Lower
3	3	130491	Ball Valve R.H.
4	2	390270	Nut M8
● 5	1	450110	Seat, Valve
6	2	550350	O-Ring 23.81 x 2.62
7	1	550545	Pressure Gauge
8	2	180370	Bolt M8 x 25
● 10	1	320420	Spring
●∅ 11	1	110121	Valve Seat
● 12	1	320433	Retainer
● 13	1	320511	O-Ring 40 x 3.53
● 14	1	390140	Gasket
15	1	550460	Elbow



## 2 REPLACEMENT PARTS (CONTINUED)

### 2.5 VALVE ASSEMBLY GS40 (Continued)

<u>REF.</u>	<u>QTY.</u>	<u>PART NO.</u>	<u>DESCRIPTION</u>
16	1	550440	Threaded Adapter
17	1	320410	Body, Upper
18	2	320480	Pin
19	1	320460	Fork
20	1	320470	Lever
21	1	320490	Locking Clip
22	1	320450	Adjustment Nut
23	1	320440	Guide
24	1	110190	Spring
25	1	230120	Seat
28	1	320406	Bracket
30	1	450145	Flange
31	1	550450	Ring Nut
32	1	110130	Fitting
33	2	160660	Bolt M8 x 35
36	1	880830	O-Ring
38	1	180101	O-Ring
43	2	130492	Ball Valve L.H.
44	1	1041210	Extension
45	1	1041220	Adapter
46	1	881560	Elbow

Ø KIT 1922		● KIT 1757			
Ref.	Qty.	Ref.	Qty.	Ref.	Qty.
11	5	5	1	13	1
		10	1	14	1
		11	1		
		12	1		

## 2 REPLACEMENT PARTS (CONTINUED)

### 2.6 OPTIONAL SPRAYER BOOMS

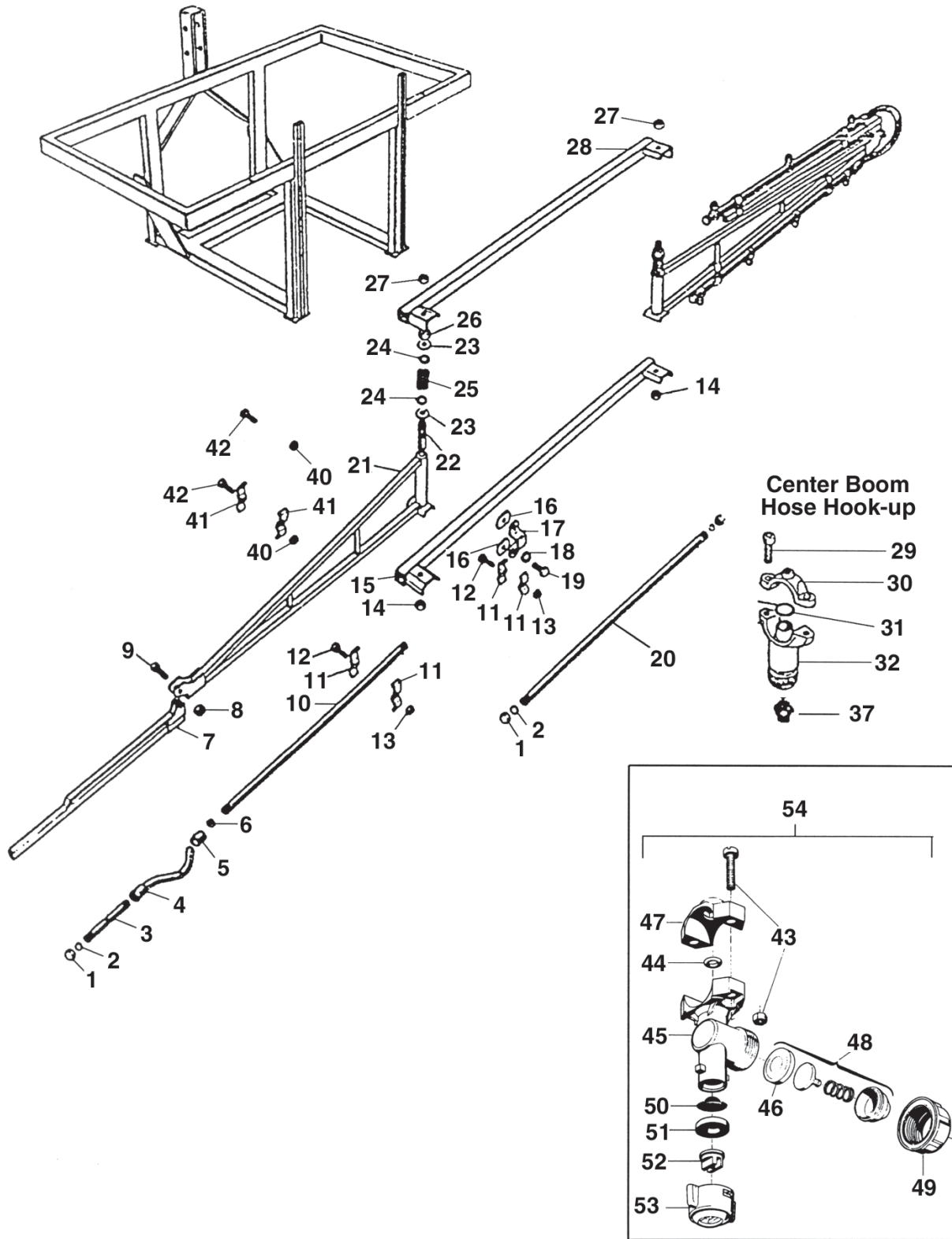

## 2 REPLACEMENT PARTS (CONTINUED)

### 2.6 OPTIONAL SPRAYER BOOMS (Continued)

<u>REF.</u>	<u>QTY.</u>	<u>PART NO.</u>	<u>DESCRIPTION</u>
1	4	0100097	Blind Plug 1/2
2	4	1700021	Gasket 19
3	2	2000011	S S Tube 20/500 G28B 41 1/2
4	2	1600024	Complete Hose 10 x 19 l=620
5	4	1300003	Self Lock Nut Connector 10 x 19
6	4	1700010	Gasket
7	2	0100111	Support G28B
8	2	1800186	Self Lock Nut M10
9	2	1800041	Bolt M10 x 45
10	2	2000018	Stainless Steel Tube G14B
10	2	2000002	Stainless Steel Tube G20B
10	2	2000011	Stainless Steel Tube G28B
11	12	0100098	Plate
12	6	1800059	Bolt M8 x 25
13	6	1800180	Nut M8
14	2	1800200	Nut M16
15	1	0100102	Inferior Support G14B & G20B
16	8	0100107	Plate
17	4	0100108	Clamp
18	8	1800130	Washer 10
19	8	1800036	Bolt M10 x 25
20	1	2000012	Stainless Steel Tube G14B & G28B
20	1	2000003	Stainless Steel Tube G20B
21	2	0100118	Support G14B
21	2	0100104	Support G20B
21	2	0100110	Support G28B
22	2	0100105	Pin
23	4	0100106	Washer 20 x 55
24	4	1800165	Washer 20
25	2	2500002	Spring
26	2	1800212	Nut M20 x 1.5
27	2	1800195	Nut M14
28	1	0100103	Superior Support G14B & G20B
36	9-12-17	1700022	Gasket 10
37	1	1300022	Nipple MF 1/2 - 3/8
40	6	1800179	Nut M6
41	2	0100112	Support
42	6	1800014	Bolt M6 x 20
43	18-34	P3400100	Bolt & Nut

## 2 REPLACEMENT PARTS (*CONTINUED*)

### 2.6 OPTIONAL SPRAY BOOMS (*Continued*)

<u>REF.</u>	<u>QTY.</u>	<u>PART NO.</u>	<u>DESCRIPTION</u>
44	9-12-17	400020.030	O-Ring D.6 x 2.5
45	9-12-17	402225.010	Nozzle Body
46	9-12-17	00226010	Diaphragm, Anti-Drip
47	9-12-17	400020.020	Nozzle Clamp
48	9-12-17	00226011	Anti-Drip Assembly
49	9-12-17	00226002	Nut 3/4" GAS
50	9-12-17	02311000	Filter
51	9-12-17	02309010	Gasket
52	9-12-17	30-04F80RE	Jet 80O (Red)
52A	9-12-17	30-03F110UB	Jet 110O (Blue)
53	9-12-17	402900	Cap, Quick Coupling
54	9-12-17	402225C	Complete Nozzle Assembly (96)

#### Quantity Count:

G14B  
9

G20B  
12

G28B  
17

## 2 REPLACEMENT PARTS (CONTINUED)

### 2.7 NOZZLE SPACING

$$\text{GPM (Per Nozzle)} = \frac{\text{GPA} \times \text{MPH} \times \text{W}}{5940}$$

$$\text{GPA} = \frac{5940 \times \text{GPM (Per Nozzle)}}{\text{MPH} \times \text{W}}$$

GPM - Gallons Per Minute

GPA - Gallons Per Acre

MPH - Miles Per Hour

- W - Nozzle spacing in inches for broadcast spraying  
 - Spray width in inches for single nozzles, band spraying or boomless spraying  
 - row spacing in inches divided by the number of nozzles per row for directed spraying

#### Tractor Speeds

Speed In MPH (miles per hour)	Time Required in SECONDS to Travel a Distance of:		
	100 feet	200 feet	300 feet
3.0	23	45	68
3.5	20	39	58
4.0	17	34	51
4.5	15	30	45
5.0	14	27	41
6.0		23	34
7.0		19	29
7.5		18	27
8.0		17	26
9.0		15	23

If the nozzle spacing on your boom is different than those tabulated, multiply the tabulated GPA coverages by one of the following factors.

Where Tables Are Based on 20" Nozzle Spacing									
Other Spacing	8"	10"	12"	14"	16"	18"	22"	24"	30"
Conversion Factor	2.5	2	1.7	1.4	1.3	1.1	0.9	0.8	0.7

Where Tables Are Based on 40" Nozzle Spacing									
Other Spacing	28"	30"	32"	34"	36"	38"	42"	44"	48"
Conversion Factor	1.4	1.3	1.3	1.2	1.1	1.1	1	0.9	0.8

#### SUGGESTED MINIMUM SPRAY HEIGHTS

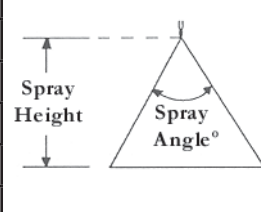
Spray Angle	Spray Height	
	20" Spacing	
65	22" to 24"	
73	20" to 22"	
80	17" to 19"	
110	10" to 12"	

\*Spray angles apply to flat spray tips spraying at rated pressure of 40 P.S.I. Lower pressures will result in reduced spray angles, except for the XR TeeJet.

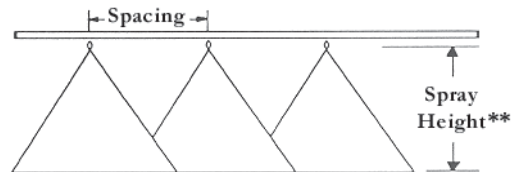

\*\*Adjust spray height in the field to overlap approximately 30% of each edge of pattern.

Tip Color	Tip No. (Strainer Screen Size)	Liquid Pressure in PSI	Capacity 1 Nozzle in GPM	Gallons Per Acre - 20" Spacing			
				4 MPH	5 MPH	6 MPH	7 MPH
Orange	8001 LP (100 Mesh)	15	.10	7.4	5.9	5.0	4.2
		20	.12	8.6	6.9	5.7	4.9
		30	.14	10.5	8.4	7.0	6.0
		40	.16	12.1	9.7	8.1	6.9
Green	80015 LP (50 Mesh)	15	.15	11.1	8.9	7.4	6.4
		20	.17	12.9	10.3	8.6	7.4
		30	.21	15.8	12.6	10.5	9.0
		40	.24	18.1	14.5	12.1	10.4
Yellow	8002 LP (50 Mesh)	15	.20	14.9	11.9	9.9	8.5
		20	.23	17.2	13.7	11.4	9.8
		30	.28	21.0	16.8	14.0	12.0
		40	.33	24.0	19.4	16.1	13.8
Blue	8003 LP (50 Mesh)	15	.30	22	17.8	14.9	12.7
		20	.35	26	21.0	17.2	14.7
		30	.42	32	25.0	21.0	18.0
		40	.49	36	29.0	24.0	21.0
Red	8004 LP (50 Mesh)	15	.40	30	27	19.8	17.0
		20	.46	34	27	23.0	19.6
		30	.57	42	34	28.0	24.0
		40	.65	48	39	32.0	28.0
Brown	8005 LP (50 Mesh)	15	.50	37	30	25	21
		20	.58	43	34	29	25
		30	.71	53	42	35	30
		40	.82	61	48	40	35
Grey	8006 LP (No Strainer)	15	.60	45	36	30	25
		20	.69	51	41	34	29
		30	.85	63	50	42	36
		40	.98	73	58	48	42
White	8008 LP (No Strainer)	15	.80	59	48	40	34
		20	.92	69	55	46	40
		30	1.10	84	67	56	48
		40	1.30	97	78	65	55
	8010 LP (No Strainer)	15	1.0	74	59	50	42
		20	1.2	86	69	57	49
		30	1.4	105	84	70	60
		40	1.6	121	97	81	69

## 2 REPLACEMENT PARTS (CONTINUED)

### 2.8 DRIVELINE ASSEMBLY

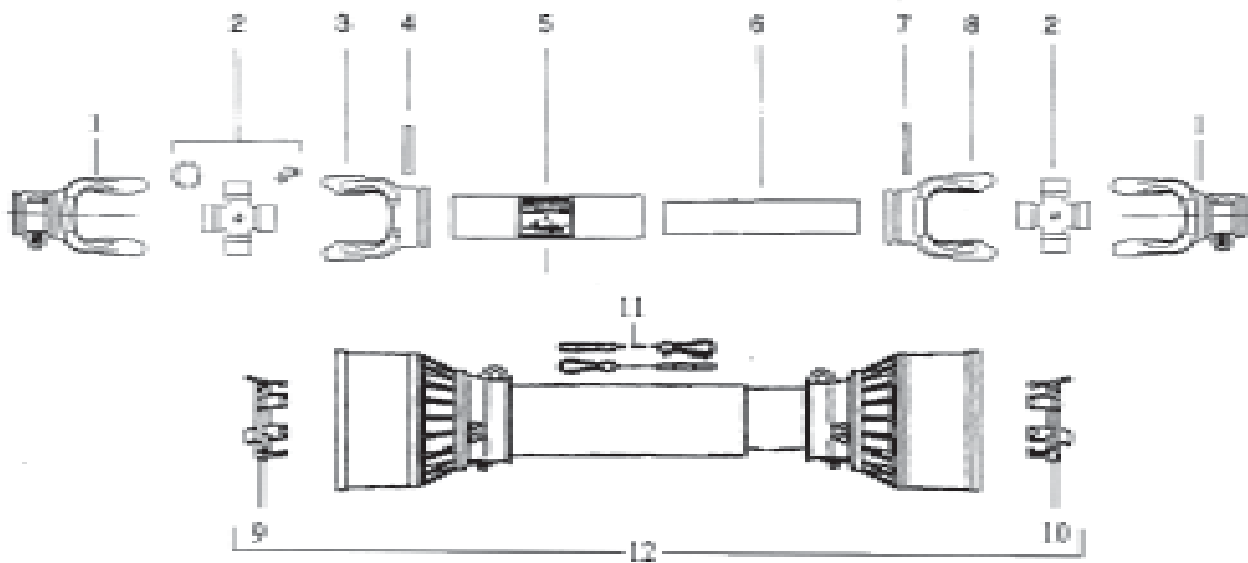

<u>REF.</u>	<u>QTY.</u>	<u>PART NO.</u>	<u>DESCRIPTION</u>
1	2	507010351	Yoke 1 3/8", 6-Spring
2	2	41201	Cross Kit #1
3	1	204016851	Outer Tube Yoke
4	1	341036000	Roll Pin
5	1	225020933	Outer Drive Tube
6	1	225010933	Inner Drive Tube
7	1	341037000	Roll Pin
8	1	204016852	Inner Tube Yoke
9	1	255010005	Outer Shield Bearing
10	1	255010006	Inner Shield Bearing
11	2	252000001	Safety Chain
12	1	5N01086N1	Complete Shield

### 3 LIMITED WARRANTY



GEARMORE, INC., warrants each new Gearmore product to be free from defects in material and workmanship for a period of twelve (12) months from date of purchase to the original purchaser. This warranty shall not apply to implements or parts that have been subject to misuse, negligence, accident, or that have been altered in any way.

Our obligation shall be limited to repairing or replacement of any part, provided that such part is returned within thirty (30) days from date of failure to Gearmore through the dealer from whom the purchase was made, transportation charges prepaid.

This warranty shall not be interpreted to render us liable for injury or damages of any kind or nature, direct, consequential or contingent, to person or property. This warranty does not extend to loss of crops, loss because of delay in harvesting or any other expenses, for any other reasons.

Gearmore in no way warrants engines, tires, or other trade accessories, since these items are warranted separately by these respective manufacturers.

Gearmore reserves the right to make improvements in design or changes in specification at any time, without incurring any obligations to owners or units previously sold.

Please be advised that all warranty work done by your dealer must be approved by Gearmore before work begins.

GEARMORE, INC.  
13477 Benson Ave.  
Chino, CA 91710

Always refer to and heed machine operating warning decals on machine.

*Please fill out the warranty registration form and return to Gearmore.  
You will find the form on our website [www.gearmore.com](http://www.gearmore.com) and can submit  
it online or print and mail to Gearmore, Inc.*