



INDUSTRIAL SCRAPER

**Operation, Service
& Parts Manual For
2G2 Series**

October 2001

TABLE OF CONTENTS

Preparation..... 1

Safety Information 2

General Information 3

Maintenance/Safety 4

Assembly Instructions 5

Parts Breakdown 6-10

S2x4-9G2 Cylinder 11

Limited Warranty 12

<p>DATE OF PURCHASE: _____</p> <p>MODEL NUMBER: _____</p> <p>SERIAL NUMBER: _____</p>
--

PREPARATION/TRAINING

WARNING

To prevent possible personal injury or death during assembly, installation, operation, adjustment or removal of implement; **DO NOT** wear loose clothing, always wear gloves and safety glasses or face shield. **Keep other persons away from any unit under power.**



READ BEFORE OPERATING BOX SCRAPER

TRAINING:

- Know your controls. Read this operator's manual and the manual provided with your tractor.
- Learn how to stop the tractor engine quickly in case of an emergency.
- **DO NOT** allow children to operate machine, or adults who do not have the proper instructions.

PREPARATION:

- Clear area of debris.
- Never permit any person, other than the operator, to ride on board the tractor at any time.
- **DO NOT** allow riders on scraper at any time.
- Operate only in daylight or good artificial light.
- **ALWAYS** wear relatively tight and belted clothing when operating scraper. Loose clothing should not be worn, as it could get caught in the moving parts or controls.
- A minimum of 20% of the tractor and equipment weight must be on the tractors front wheels with the box scraper in transport position. Without this weight, the tractor could tip over causing personal injury or death. The weight may be attained with front wheel weights, ballast in tires or front tractor weights. When attaining the minimum 20% weight on the front wheels, you must not exceed the Roll Over Protection Structure (ROPS) weight certification. Weigh tractor and equipment. Do not guess or estimate.

SAFETY INFORMATION

OPERATIONAL SAFETY:

- Read and observe all safety decals on the tractor and scraper.
- **DO NOT** stop or start suddenly when going uphill or downhill. Avoid operation on steep slopes.
- Be alert for holes in terrain and other hidden hazards. Always drive slowly over rough ground.
- Reduce speed on slopes and in sharp turns to prevent tipping or loss of control. Be careful when changing direction on slopes.
- Take all possible precautions when leaving tractor unattended: Lower scraper, shift into neutral, set parking brake, stop engine and remove key from ignition.
- Never work under scraper without safety blocks.
- This implement is designed for a one-man operation. It is the responsibility of the tractor operator to see that no one is near the implement while in use.
- Front tractor weights or front tire ballast should be used to enhance front end stability on small tractors.
- No riders are allowed on tractor or box scraper.
- Stop tractor immediately upon striking an obstruction. Turn off engine, inspect and repair any damage before resuming operation.
- Make sure area behind your tractor is clear before operating in reverse.
- Keep alert and watch ahead as well as behind the tractor when working with the box scraper.
- Ensure equipment is properly mounted to tractor before making adjustments.
- Always be sure the box scraper is in the fully raised position when in transport.
- When turning close to buildings or passing through narrow areas, be sure to allow sufficient clearance for the box scraper.
- Use extra caution when backfilling deep holes or trenches.
- Always use the tractor anti-sway bars, blocks or chains to prevent side sway. This is a must when using the box scraper for backfilling.
- Make adjustments using hydraulic controls only when seated in operator's position.

GENERAL INFORMATION

- ***CUTTING EDGES*** - are reversible so always remember to "flip" them over before wearing the back plate. Replace the cutting edge after both edges are worn to the bottom edge of the back plate.
- ***2 POSITION SHANKS*** - have a shallow or deep setting. When changing positions, make sure the shank retainer is "seated" properly in the beam. We have a special flat bottom retainer that should always stay in place if installed properly.
- ***REPLACEABLE SHANK POINT*** - make sure you replace the point before you wear the drop forged shank. Knock off the worn point and lock the new point in place by "crimping" at the recessed holes in the shank.
- ***PREVENTING DAMAGE*** - to your scraper is directly proportional to the speed you are operating at when you hit an **immovable object**. Please try to operate at slower speeds when working in unknown conditions.

MAINTENANCE SAFETY

- Lower box scraper to ground, set tractor locking system device, turn tractor engine off, and remove key before performing any service or maintenance.
- Block box scraper securely before working underneath.
- Keep all persons away from operator control area while performing adjustments, service or maintenance.
- Periodically tighten all bolts and nuts to ensure scraper is in a safe working condition.
- Before operating the scraper, always check to make sure that the lynch pins are in the lock position, so that the lift pins do not work their way out.

SERVICING INSTRUCTIONS:

CUTTING EDGE -

For reversing the cutting edge:

1. Remove $\frac{5}{8}$ " plow bolts.
2. Remove cutting edge from moldboard and reinstall with sharp edge down.
3. Replace when both edges are worn out.

BOLTS -

Keep all the bolts tight at all times by checking them periodically. Replace the bolts only with those having the same marks on the heads as on original bolt. Marks on bolt head indicate high strength.

BOLT TORQUE -

BOLT	MINIMUM	MAXIMUM
$\frac{5}{8}$ " Plow	150 Ft/lbs.	180 Ft/lbs.

LUBRICATION:

Lubricate bell crank every **50 hours** of use.

ASSEMBLY INSTRUCTIONS

1. Attach box scraper to 3-point hitch lower lift arms using pins supplied.
2. Attach 3-point hitch top link to a-frame mast on scraper using pin supplied.
3. Make sure the box scraper is sitting on the ground and the tractors' safety device is set.
4. Install fittings (*dealer supplied*) to the hydraulic cylinder. ($\frac{9}{16}$ O-ring boss - JIC 6MB-6MJ)
5. Install quick couplers (*dealer supplied*) to hydraulic hoses (*dealer supplied*). Connect hoses to fittings on cylinder and couple other end to tractor hydraulic valve.
6. Crack fitting on cylinder and cycle in order to remove air from the system.
7. Raise scraper off the ground with tractor 3-point hitch.
8. Extend cylinder to raise shank bar to upper position.
9. Retract cylinder to lower shank bar to working position. Be certain to check that the bell crank has fully engaged onto the frame lock lug to avoid pressure on the cylinder and linkage when in use.

REPLACEMENT PARTS

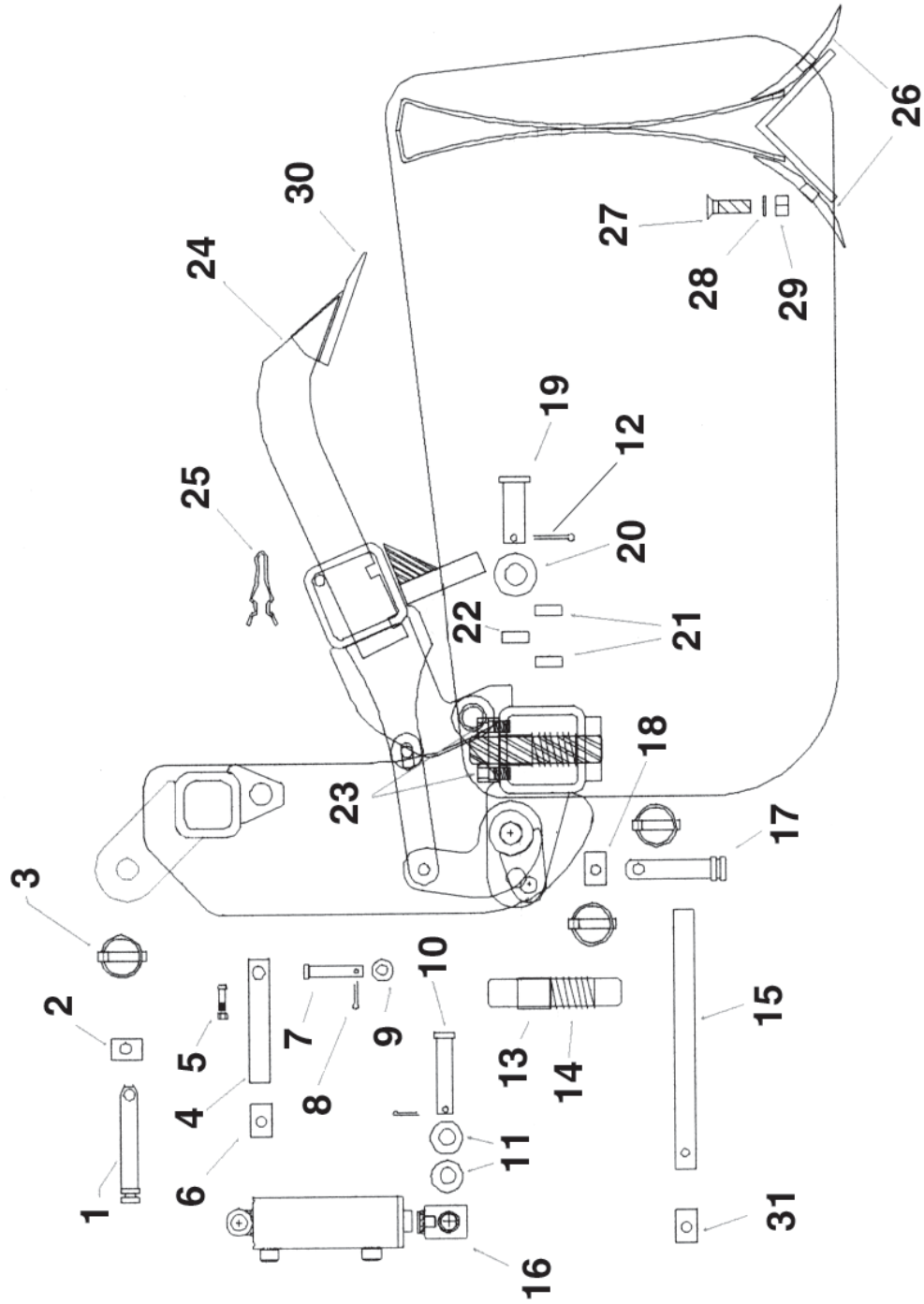

REPLACEMENT PARTS

REF #	PART NO.	DESCRIPTION	QTY			
			60"	66"	72"	76"
1	P075500C1TL	Cat. 1 Top Link Pin	1	1	1	1
2	X01A31P	Top Link Pin Stop	1	1	1	1
3	P716175LY	Lynch Pin	3	3	3	3
4	R04AB001	Top Cylinder Rod	1	1	1	1
5	SS516075	Set Screw	2	2	2	2
6	SC075050SSC	Cylinder Rod Lock Collar ³ / ₄ "	1	1	1	1
7	P050175CL	Link Pin ¹ / ₂ " x 1 ³ / ₄ " Clevis	2	2	2	2
8	P532125C0T	⁵ / ₃₂ " x 1 ¹ / ₄ "v Cotter Pin	2	2	2	2
9	W050SAEF	Link Pin washer ¹ / ₂ " SAE	4	4	4	4
10	P075300CL	Cylinder Pin ³ / ₄ " x 3"	1	1	1	1
11	W075SAEF	Lower Cyl Pin Wshr ³ / ₄ " SAE Flat	2	2	2	2
12	P316150C0T	³ / ₁₆ " x 1 ¹ / ₂ " Cotter Pin	3	3	3	3
13	R08A001	Main Shank Bar Lock Pin	1	1	1	1
14	S1516325C0M	Shank Bar Lock Pin Spring	1	1	1	1
15	R05A09	Bell Crank Shaft 1" x 11.5"	1	1	1	1
16	S2X4-9G2	Hydraulic Cylinder	1	1	1	1
17	P078400CL	Cat. 1 Draw Pin	2	2	2	2
18	X02A31P	Ind. BS Pin Stop	2	2	2	2
19	P100238CL	Pivot Plate Pin 1" x 2 ³ / ₈ "	2	2	2	2
20	W100SAEF	1" Machine Washer	4	4	4	4
21	HB125050	Pivot Plate Ear Bushing	4	4	4	4
22	HB125050	Pivot Plate Bushing	2	2	2	2
23	B038100-5	Top Main Lock Pin Plate Bolts	2	2	2	2
24	G163	Shank With Point	5	6	7	7
25	SR100	Shank Retainer	5	6	7	7
26	CE60	Cutting Edge	2			
26	CE66	Cutting Edge		2		
26	CE72I	Cutting Edge			2	
26	CE76I	Cutting Edge				2
27	GR85/8X2	Cutting Edge Plow Bolt	10	12	12	14
28	W058L	Cutting Edge Lock Washer	10	12	12	14
29	GR85/8NC	Cutting Edge Hex Nut	10	12	12	14
30	RPS76931	Point For Shank	10	12	12	14
31	SC10005055	Locking Collar 1"	1	1	1	1

WELDMENT REPLACEMENT PARTS

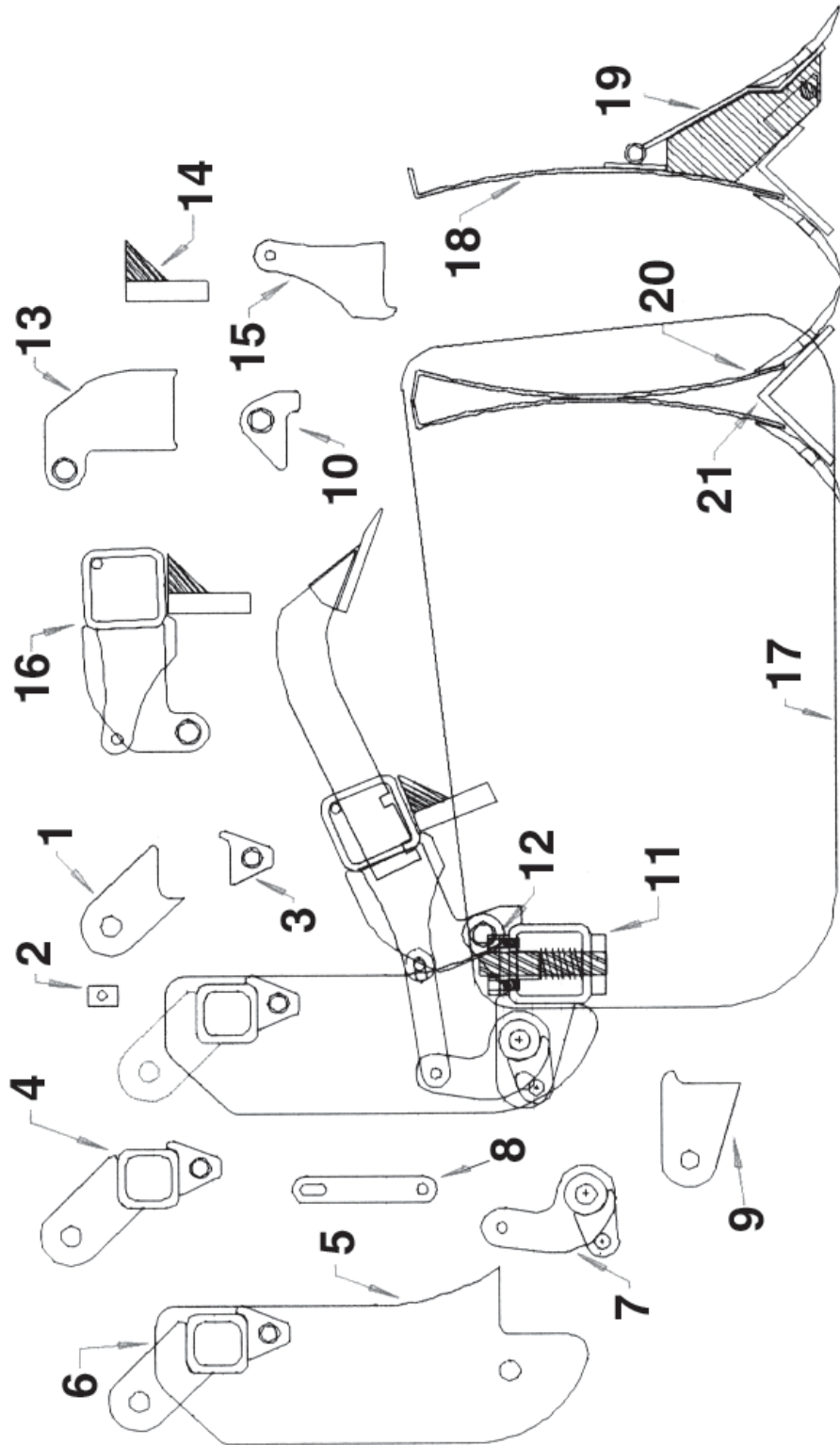

WELDMENT REPLACEMENT PARTS

REF #	PART NO.	DESCRIPTION	QTY			
			60"	66"	72"	76"
1	P03A05	Top Link Ear	1	1	1	1
2	P03A05A	Top Link Ear With Pin Stop	1	1	1	1
3	P02A100	Top Cylinder Ear	1	1	1	1
4	T04A3A	Mast Spacer Assembly (Includes mast spacer, cylinder ear and both top link ears)	1	1	1	1
5	P03A011	Mast	2	2	2	2
6	P03A011A	Mast Assembly (Includes 2 mast, mast spacer with cylinder and top link ears)	1	1	1	1
7	P04A007A	Bell Crank Assembly (Includes bell crank pipe, cylinder, arm and bell crank ears)	1	1	1	1
8	P02A11A	Link Assembly	1	1	1	1
9	P03A06	Draw Ear	4	4	4	4
10	P03A017B	Pivot Plate Ear With Bushing	4	4	4	4
11	F23AB002	Bottom Main Lock Pin Plate	1	1	1	1
12	F18A002	Top Main Lock Pin Plate	1	1	1	1
13	P03A019BA	Pivot Plate With Bushing & Brace	2	2	2	2
14	P06A001A	Latch Plate With Gussets	1	1	1	1
15	P04A0072	Shank Bar Ear	1	1	1	1
16	T13B0157A	Shank Bar Assy (Complete)	1			
16	T13A227A	Shank Bar Assy (Complete)		1		
16	T13A327A	Shank Bar Assy (Complete)			1	
16	T13A427A	Shank Bar Assy (Complete)				1
17	P02A01	2G2 Side Plate	2	2	2	2
18	P00A129TA	Back Plate Assy 2G2-60T (no tailboard or cutting edge)	1			
18	P00A229TA	Back Plate Assy 2G2-66T (no tailboard or cutting edge)		1		
18	P00A329TA	Back Plate Assy 2G2-72T (no tailboard or cutting edge)			1	
18	P00A429TA	Back Plate Assy 2G2-76T (no tailboard or cutting edge)				1
19	P00AB431A	Tailboard Assy (no cutting edge)	1			
19	P00A531A	Tailboard Assy (no cutting edge)		1		
19	P00A631A	Tailboard Assy (no cutting edge)			1	
19	P00A731A	Tailboard Assy (no cutting edge)				1
20	P00A129A	Back Plate Assy w/Bridge (no cutting edge)	1			

WELDMENT REPLACEMENT PARTS

REF #	PART NO.	DESCRIPTION	QTY			
			60"	66"	72"	76"
20	P00A229A	Back Plate Assy w/Bridge (no cutting edge)		1		
20	P00A329A	Back Plate Assy w/Bridge (no cutting edge)			1	
20	P00A429A	Back Plate Assy w/Bridge (no cutting edge)				1
21	A09A124A	Back Plate Bridge Assy (Includes bridge and bridge gussets)	1			
21	A09A224A	Back Plate Bridge Assy (Includes bridge and bridge gussets)		1		
21	A09A324A	Back Plate Bridge Assy (Includes bridge and bridge gussets)			1	
21	A09A424A	Back Plate Bridge Assy (Includes bridge and bridge gussets)				1

S2X4-9G2 CYLINDER

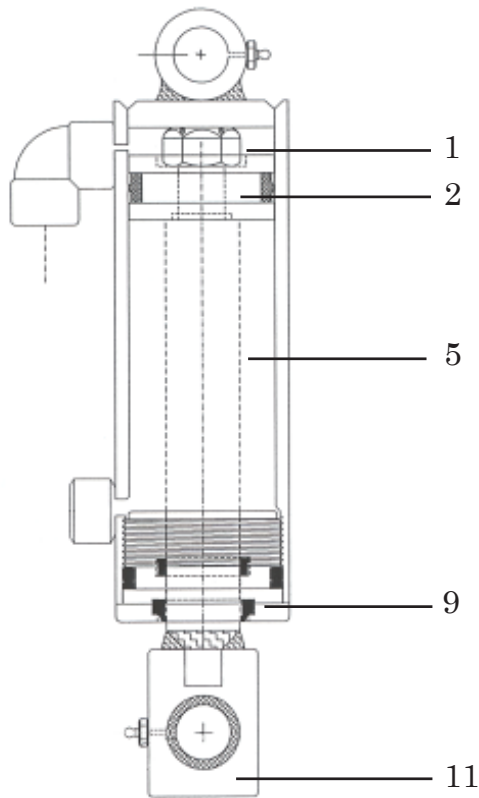

REF #	PART NO.	DESCRIPTION	QTY.
1	IT2N	Crimped Locknut	1
2	LC2V	Piston	1
3	*	Crown Seal	1
4	*	O-Ring	1
5	IT2C	Barrel	1
6	*	Rod Seal	1
7	*	O-Ring	1
8	*	Back-up Ring	1
9	IT2E-S-1.2	Gland	1
10	*	Wiper Seal	1
11	IT2S	Piston Rod	1
*Parts available in packing kit only	SK24-6	Packing Kit (Consists of 1 ea. Ref. No. 3, 4, 6, 7, 8, & 10)	1

LIMITED WARRANTY



GEARMORE, INC., warrants each new Gearmore product to be free from defects in material and workmanship for a period of twelve (12) months from date of purchase to the original purchaser. This warranty shall not apply to implements or parts that have been subject to misuse, negligence, accident, or that have been altered in any way.

Our obligation shall be limited to repairing or replacement of any part, provided that such part is returned within thirty (30) days from date of failure to Gearmore through the dealer from whom the purchase was made, transportation charges prepaid.

This warranty shall not be interpreted to render us liable for injury or damages of any kind or nature, direct, consequential or contingent, to person or property. This warranty does not extend to loss of crops, loss because of delay in harvesting or any other expenses, for any other reasons.

Gearmore in no way warrants engines, tires, or other trade accessories, since these items are warranted separately by these respective manufacturers.

Gearmore reserves the right to make improvements in design or changes in specification at any time, without incurring any obligations to owners or units previously sold.

GEARMORE, INC.
13477 Benson Ave.
Chino, CA 91710

Always refer to and heed machine operating warning decals on machine.

The serial number of this product is stored in our computer database, thus submitting a warranty registration card is not required.