



VENTURI AIR SPRAYERS

**Parts Manual For
Model L50S1-1200
Link Trailer**

December 2002

TABLE OF CONTENTS

Frame Assembly	1-3
Axle Assembly	4
Tank Assembly	5-6
Agitation Assembly	7-8
Fresh Water Tank Assembly	9
Fan Assembly	10
Fan Support & Belt Tensioner	11-13
Main Drive Pulley & Clutch Assembly	14-15
Fan Support	16
Liquid Flow Path	17-19
Agitation Pump Flow Path	20
In-Line Filter Assembly	21
Shower Head Assembly	22
Pump Tension Pulley Assembly	23-25
Manually Operated Valve	26
Manual Command Group 2-Way	27
Optional Control Box For Solenoid Valve	28
Optional Solenoid Control Valve	29-30
PTO Driveshaft	31
Limited Warranty	32

Date of Purchase: _____

Model Number: _____

Serial Number: _____

FRAME ASSEMBLY

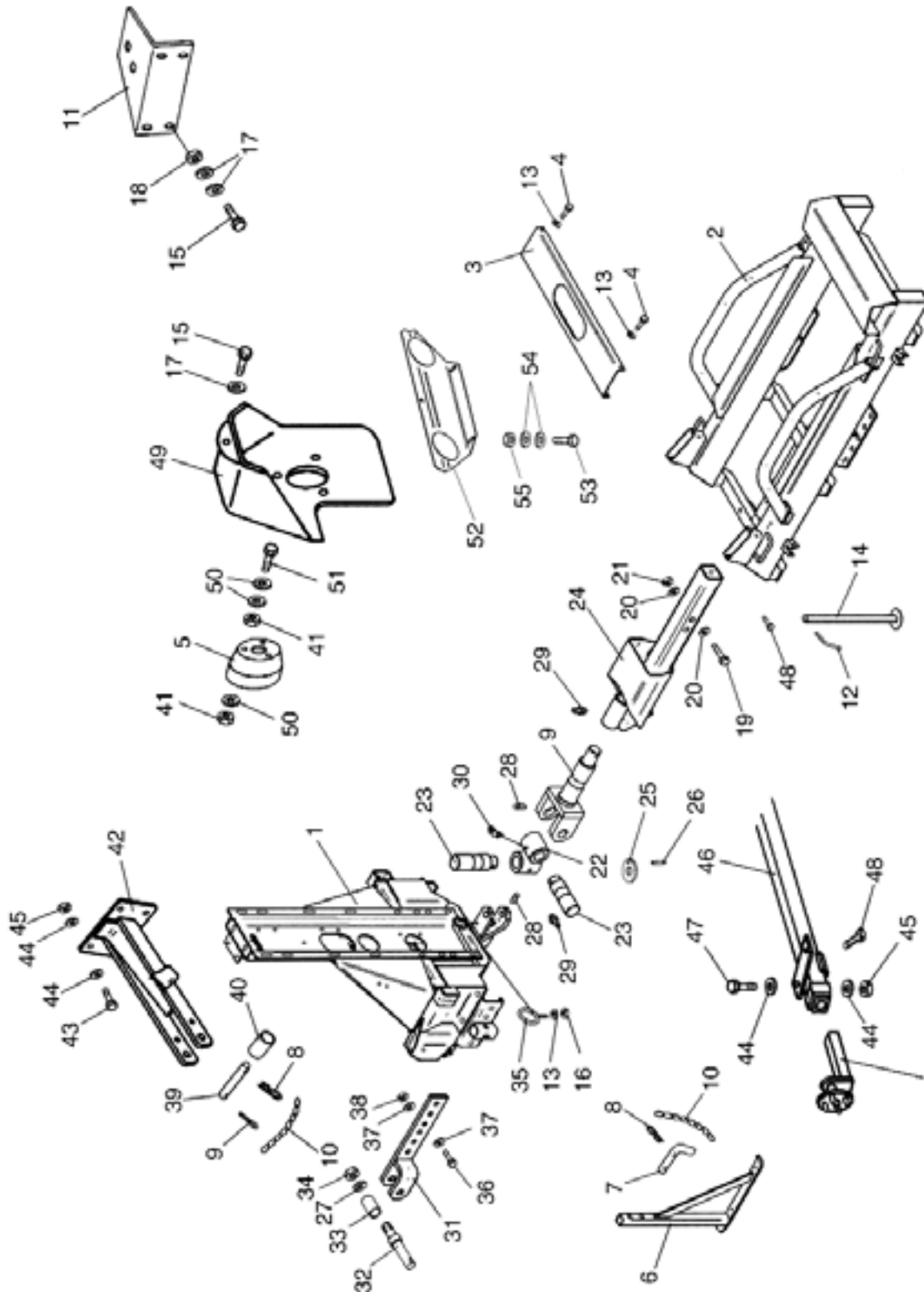

See Page 4

FRAME ASSEMBLY

<u>REF#</u>	<u>QTY.</u>	<u>PART NO.</u>	<u>DESCRIPTION</u>
1	1	05.950.500	Frame, 3-Point
2	1	40.241.000	Frame, Trailer
3	1	40.244.000	Cover Plate
4	4	TE.008.020T	Bolt M8 x 20
5	1	02.441.000	Cone, PTO
6	2	40.217.000	Support Stand
7	1	20.505.000	Pin
8	3	00.100.004	Hair Pin
9	1	40.194.100	Fork, Drawbar
10	2	02.278.030	Chain D.22 L=300
11	1	40.208.001	Bracket, Handwash Tank
12	1	02.175.000	Pin
13	5	RP.008.000	Washer D.8
14	1	40.251.000	Storage Stand
15	5	TE.010.030T	Bolt M10 x 30
16	1	DA.008.OAG	Nut M8
17	9	RP.010.030	Washer D.10 x 30
18	4	D0.10.5587G	Nut M10
19	1	TE.018.110	Bolt M18 x 110
20	2	RP.018.000	Washer D.18
21	1	DA.018.OAG	Nut M18 x 2.5
22	1	40.195.100	Knuckle
23	2	40.193.000	Pin
24	1	40.215.001	Drawbar
25	1	40.206.000	Washer D.50 x 25
26	1	SE.006.020	Roll Pin D.6 x 20
27	2	RD.022.000	Tab Washer D.22
28	2	VCE.06.20.23	Set Screw 6 x 20
29	2	ID.010.001	Grease Zerk M10 x 1
30	1	IS.010.001	Grease Zerk 90° M10 x 1
31	2	40.203.000	Lift Arm
32	2	40.201.000	Lift Pin
33	2	40.202.000	Bushing D.28.5 x 22 L=54
34	2	DI.022.5593F	Nut M22
35	1	20.785.000	Guide Ring
36	4	TE.016.050T	Bolt M16 x 50
37	8	RP.016.000	Washer D.16
38	4	D0.16.5587G	Nut M16
39	1	04.076.000	Pin, Top Link
40	1	20.778.000	Bushing

FRAME ASSEMBLY

<u>REF#</u>	<u>QTY.</u>	<u>PART NO.</u>	<u>DESCRIPTION</u>
41	6	D0.06.5588G	Nut M6
42	1	40.205.001	Fixing Bracket
43	4	TE.012.030T	Bolt M12 x 30
44	16	RP.012.000	Washer D.12
45	8	D0.12.5587G	Nut M12
46	1	40.126.002	Support Tube, Axle
47	4	TE.012.040T	Bolt M12 x 40
48	6	TE.014.030T	Bolt M14 x 30
49	1	05.723.050	Cover
50	9	RP.006.000	Washer D.6
51	3	TE.006.025T	Bolt M6 x 25
52	1	05.747.000	Fixing Plate
53	2	TE.008.030T	Bolt M8 x 30
54	4	RP.008.024	Washer D.8 x 24
55	2	DO.08.5588G	Nut M8

AXLE ASSEMBLY

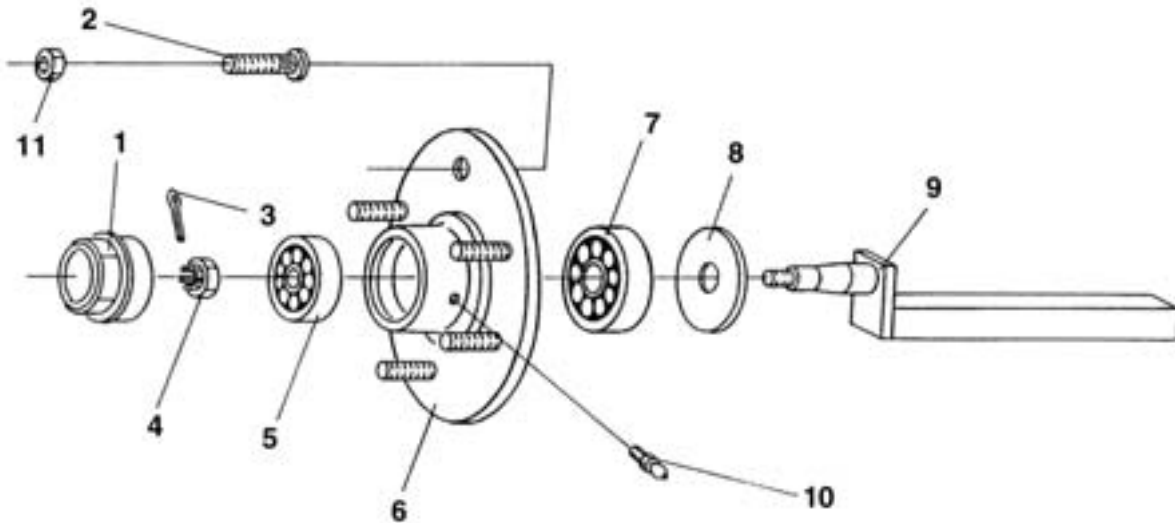

<u>REF#</u>	<u>QTY.</u>	<u>PART NO.</u>	<u>DESCRIPTION</u>
1	1	04.062.001	Dust Cap
2	6	05.911.001	Stud, Drive-In
3	1	(Obtain Locally)	
4	1	DI.027.5593F	Castellated Nut
5	1	30206	Bearing
6	1	05.903.001	Hub
7	1	30209	Bearing
8	1	20.258.000	Cover D.45 x 85
9	1	04.690.003	Axle
10	1	ID.006.001	Grease Nipple
11	6	05.911.000	Lug Nut

TANK ASSEMBLY

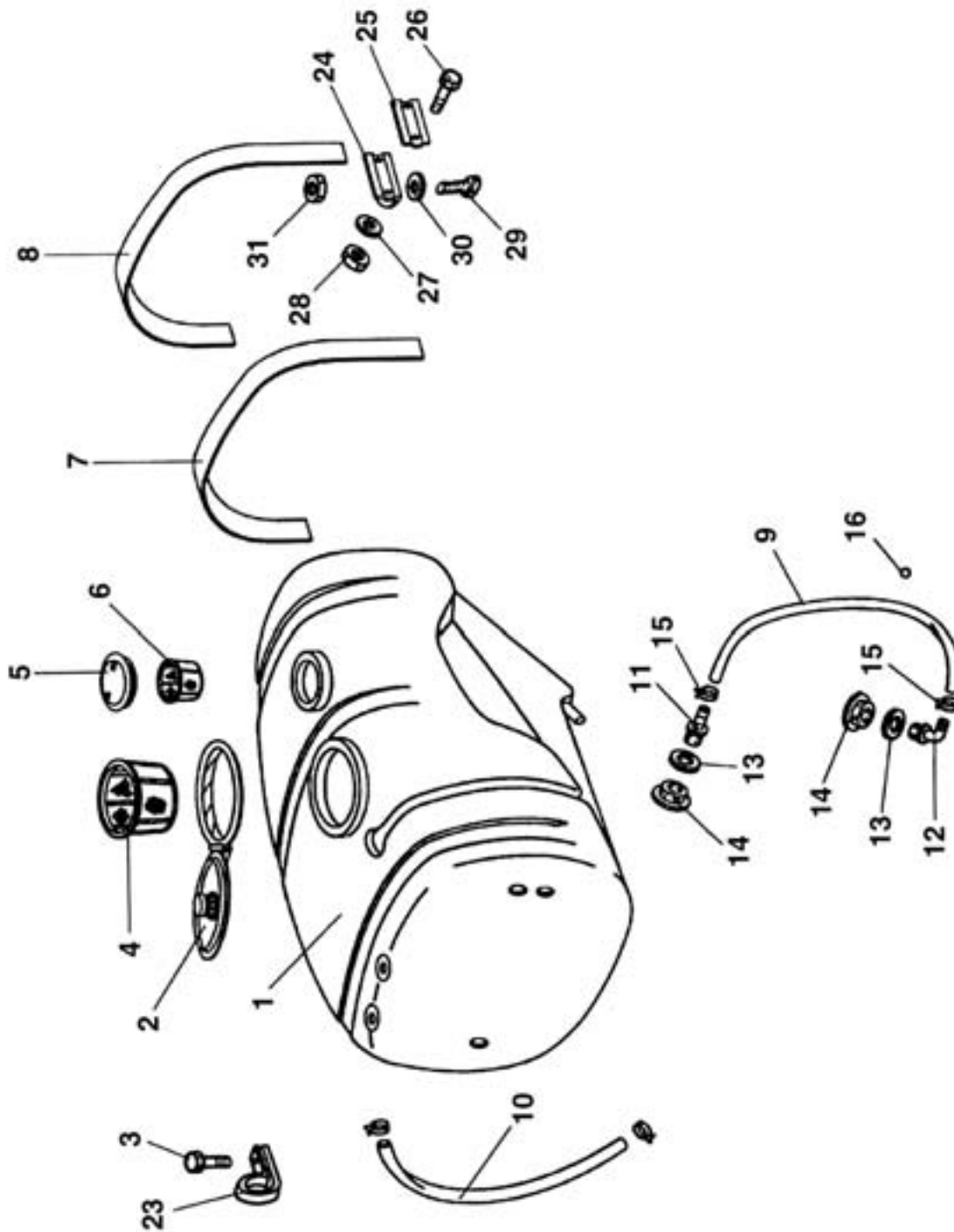

TANK ASSEMBLY

<u>REF#</u>	<u>QTY.</u>	<u>PART NO.</u>	<u>DESCRIPTION</u>
1	1	40.118.110C	Poly Tank 300 Gallon
2	1	02.405.000	Lid Assembly
3	2	TE.006.016T	Bolt M6 x 16
4	1	02.404.000	Strainer Basket 400 x 330
5	1	02.476.000	Small Lid
6	1	02.298.000	Strainer Basket D.204
7	1	02.481.277	Nylon Strap L=2770
8	1	02.481.253	Nylon Strap L=2530
9	1	02.378.160	Sight Gauge Hose D.12 x 16 L=1600
10	1	02.378.085	Sight Gauge Hose D.12 x 16 L=850
11	2	02.482.000	Threaded Nipple D.13 x 1/2"
12	2	02.457.000	Threaded Elbow D.13 x 1/2"
13	4	OR2022353	O-Ring 20.22 x 3.53
14	4	02.458.000	Plastic Nut 1/2"
15	4	F0.008.016I	Clamp D.8 x 16
16	2	02.478.000	Float Ball D.8.5
23	2	FG.018.000	Hose Support
24	4	20.512.000	Clamp, Strap
25	4	20.513.000	Clamp, Strap
26	8	TE.006.020T	Bolt M6 x 20
27	8	RP.006.000	Washer D.6
28	8	DA.006.OAG	Nut M6
29	4	TE.010.080T	Bolt M10 x 80
30	4	RP.010.000	Washer D.10
31	4	DOT.10.5587	Nut M10

AIR AGITATION ASSEMBLY

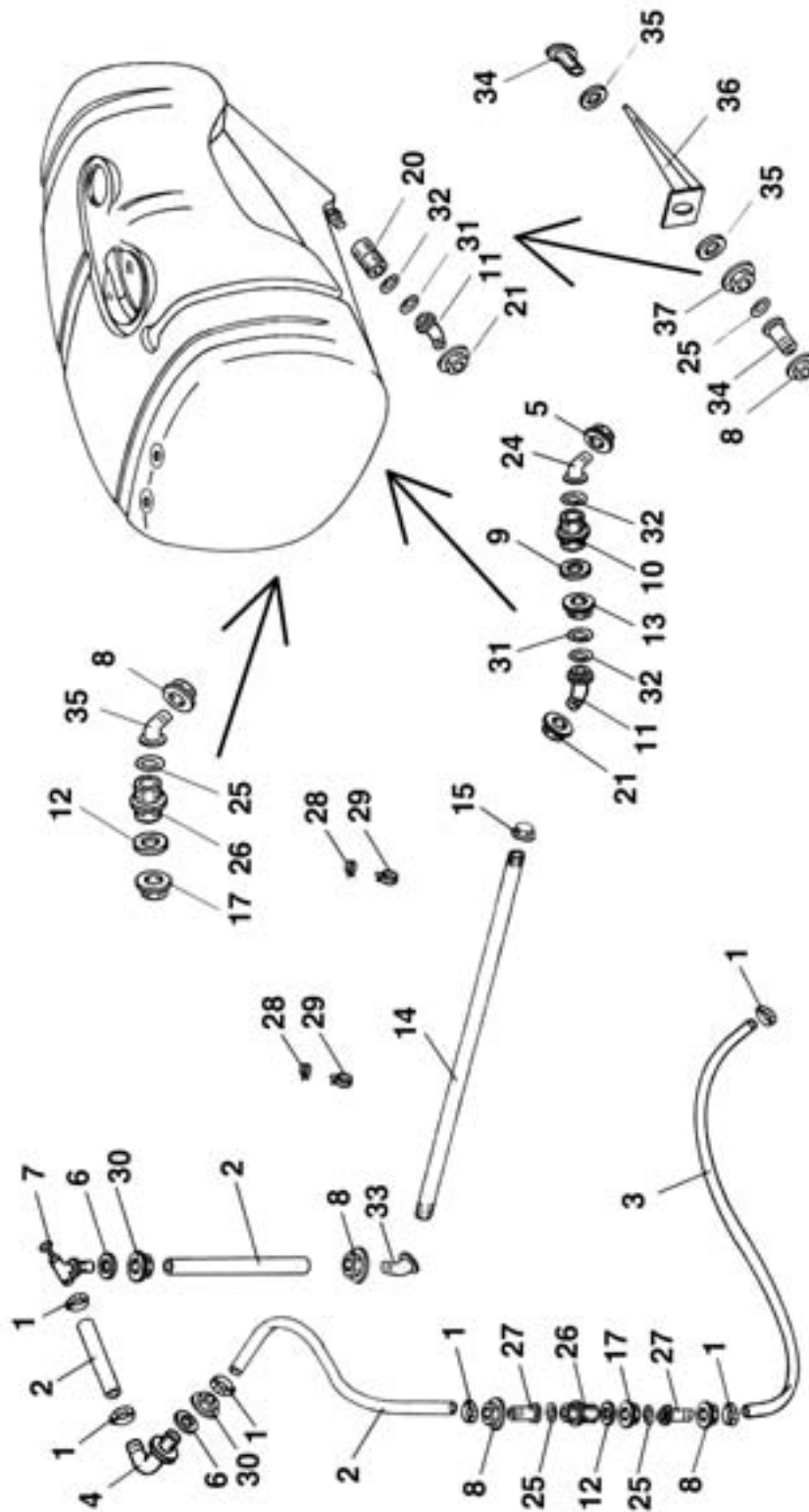

AIR AGITATION ASSEMBLY

<u>REF#</u>	<u>QTY.</u>	<u>PART NO.</u>	<u>DESCRIPTION</u>
1	6	FO.016.027I	Clamp D.16 x 27
2	As Req'd	02.212.000	Hose D.19 Per Foot
3	As Req'd	02.372.000	Hose D.19 Per Foot
4	1	02.290.000	Elbow D.19
5	1	00.058.006	Nut 1-1/4"
6	2	02.032.000	Gasket D.26 x 40
7	1	02.135.000	Piston
8	5	00.055.24.2	Plastic Nut 1" Gas
9	2	02.033.000	Gasket D.42 x 55 x 3
10	1	2502051	Threaded Nipple 1-1/4H=50/24
11	2	02.339.000	Elbow D.30
12	4	02.066.000	Gasket D.33 x 45
13	1	00.543.000	Cap 1-1/4" Gas
14	1	40.035.001	Tube 1" L=1200
15	2	TF.001.000	Cap 1"
16	1	02.265.000	Gasket D.29 x 3
17	3	00.542.000	Plastic Nut 1" Gas
18	1	20.498.000	Support Bracket
19	1	00.587.000	Nipple 1" Gas
20	1	20.788.000	Reducer
21	2	00.493.000	Plastic Nut 1-1/4"
22	1	00.058.006	Plastic Nut
23	1	00.058.028	Nipple D.30
24	1	00.058.004	Nipple 45° D.30
25	4	OR2381262	O-Ring 23.81 x 2.62
26	2	2502041	Threaded Nipple 1" H=45/22
27	2	00.055.022	Nipple D.19
28	2	F0.025.040I	Clamp 25/40
29	2	F0.016.025I	Clamp 16/25
30	2	00.541.000	Plastic Nut
31	2	OR2664262	O-Ring 26.64 x 2.62
32	3	OR2824262	O-Ring 28.24 x 2.62
33	1	00.055.038	Elbow D.19
34	1	00.055.021	Hose Barb
35	1	00.055.037	Elbow

FRESH WATER TANK ASSEMBLY

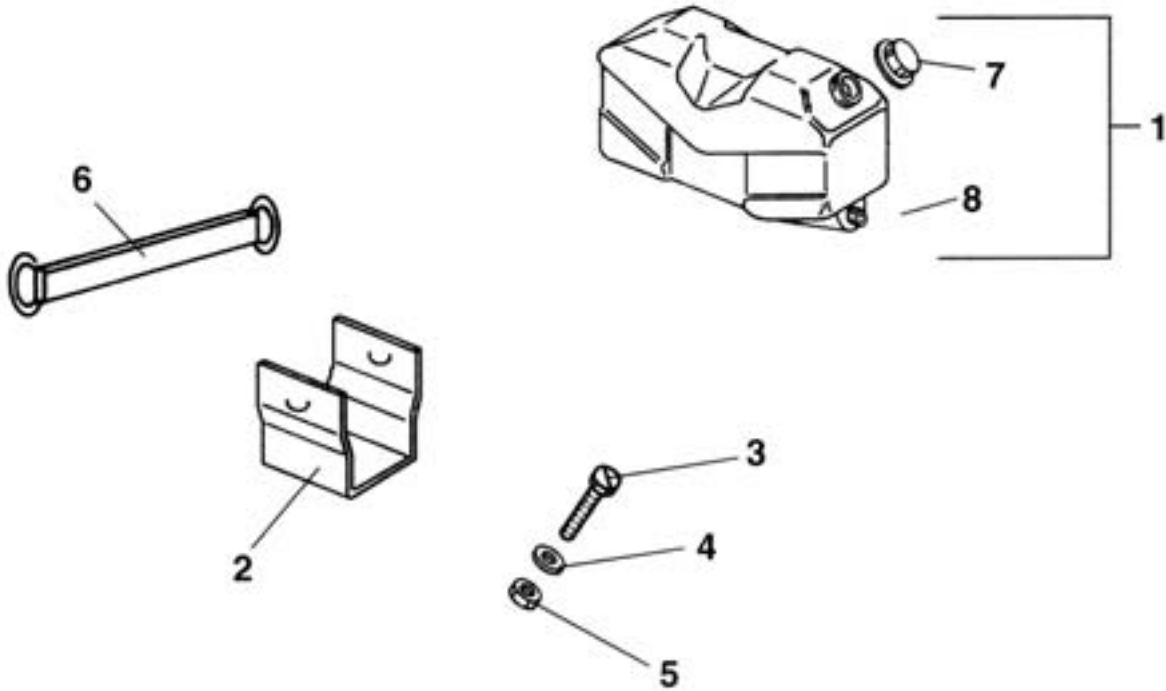

<u>REF#</u>	<u>QTY.</u>	<u>PART NO.</u>	<u>DESCRIPTION</u>
1	1	02.437.000	Tank Assembly
2	1	20.335.000	Bracket, Mount
3	2	TS.008.020T	Bolt M8 x 20
4	2	RP.008.000	Washer D.8
5	2	D0.08.5588G	Nut M8
6	1	02.438.000	Rubber Strap
7	1	02.460.000	Cap
8	1	02.452.000	Drain Valve

FAN ASSEMBLY

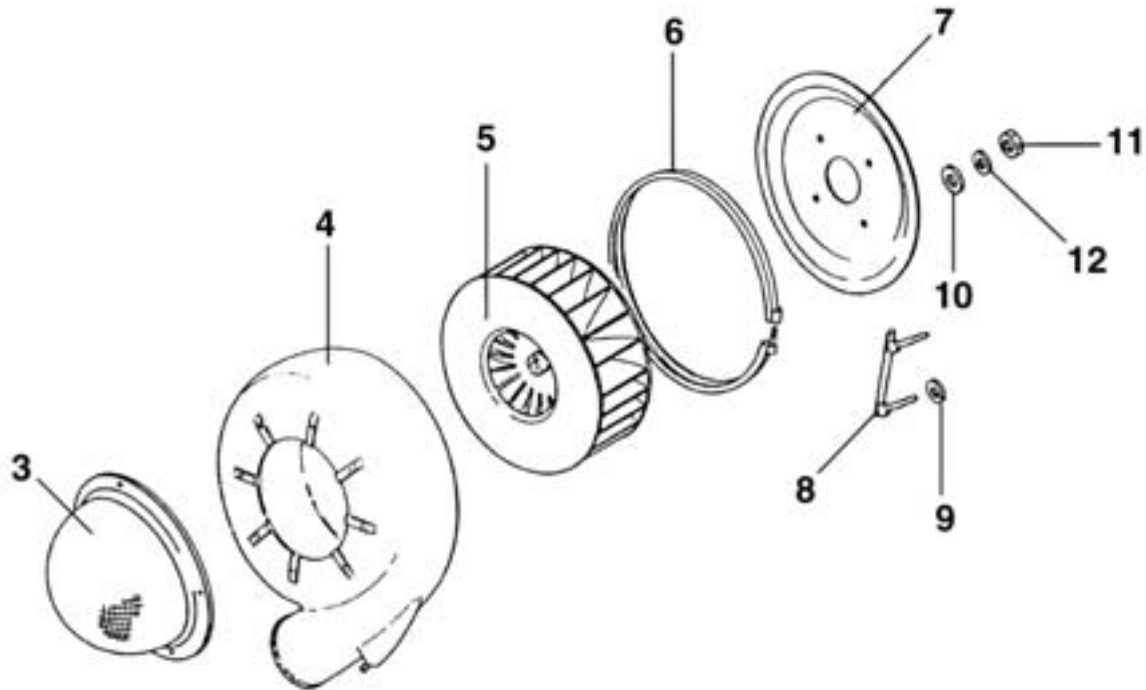

<u>REF#</u>	<u>QTY.</u>	<u>PART NO.</u>	<u>DESCRIPTION</u>
1	4	TE.006.010T	Screen Bolt M6 x 10 (not shown)
2	4	RP.006.024	Washer D.6 x 24 (not shown)
3	1	05.654.100	Cover, Wire Mesh
4	1	05.730.000	Housing
5	1	05.732.000	Fan
6	1	05.731.000	Clamp D.485
7	1	50.120.000	Cover
8	2	20.088.000	Bolt Assembly
9	4	RP.010.000	Washer D.10
10	4	RP.010.040	Washer D.10 x 40
11	4	DO.10.5587G	Nut M10
12	4	RP.010.030	Washer D.10 x 30

FAN SUPPORT & BELT TENSIONER

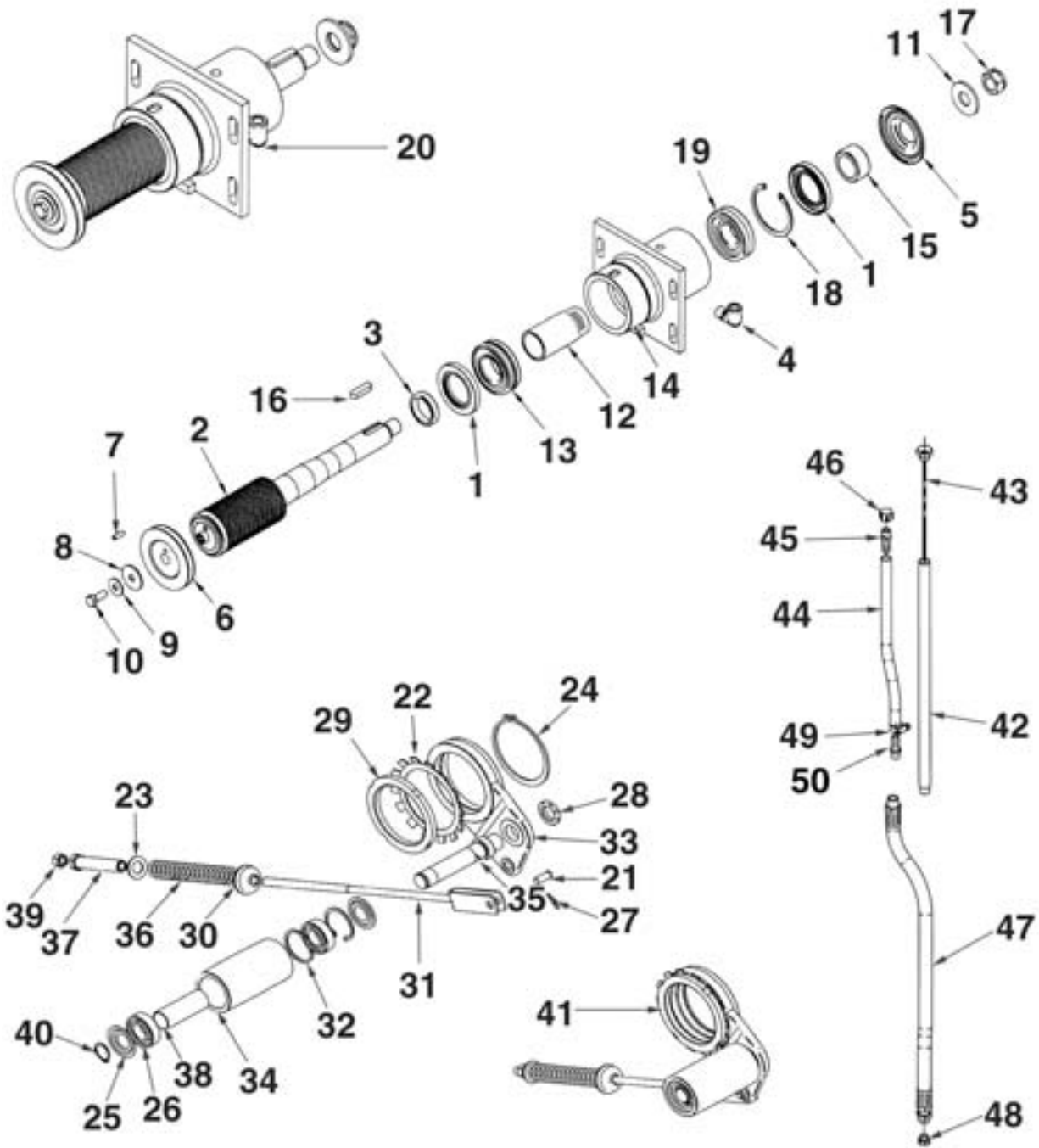

FAN SUPPORT & BELT TENSIONER

<u>REF#</u>	<u>QTY.</u>	<u>PART NO.</u>	<u>DESCRIPTION</u>
1	2	50X80X10	Oil Seal
2	1	50.119.060	Shaft D.60
3	1	50.114.000	Bushing
4	1	20.789.000	90° Elbow
5	1	50.115.000	Cover
6	1	05.746.000	Pulley D.82
7	1	SE.006.020	Roll Pin
8	1	RP.010.040	Washer D.10 x 40
9	1	RP.010.028	Washer D.10 x 28
10	1	TE.010.025FT	Bolt M10 x 25
11	1	20.820.000	Washer D.53/D.22.5
12	1	50.112.000	Spacer
13	1	22208	Bearing
14	1	50.110.000	Housing
15	1	50.113.000	Spacer
16	1	L.10.08.40	Key 10 x 8 x 40
17	1	DA.022.0BF	Nut M22 x 1.5
18	1	I0.080.000	Circlip I80
19	1	21307	Bearing
20	1	50.137.000	Support Assembly

BELT TENSIONER

21	1	04.593.000	Pin
22	1	MB.020.000	Washer
23	1	RP.019.000	Washer D.19
24	1	E0.100.000	Circlip E100
25	2	04.585.000	Cover, Dust
26	2	6205-2RS	Bearing
27	1	00.100.002	Hair Pin
28	1	KM.005.000	Nut M5
29	1	05.704.000	Nut
30	1	20.260.000	Cup Washer
31	1	05.653.000	Rod, Adjustment
32	2	I0.052.000	Circlip I52
33	1	05.696.000	Support, Idler
34	1	05.630.000	Roller
35	1	05.697.000	Pin
36	1	05.647.000	Spring
37	1	04.583.000	Special Screw
38	1	05.631.000	Spacer
39	1	D0.12.5588G	Nut m12
40	1	E0.025.000	Circlip E25
41	1	05.707.001	Belt Tension Assembly

FAN SUPPORT & BELT TENSIONER

OIL TUBE

<u>REF#</u>	<u>QTY.</u>	<u>PART NO.</u>	<u>DESCRIPTION</u>
42	1	50.122.000	Pipe L=450
43	1	50.116.000	Dipstick
44	1	02.213.040	Breather D.10 L=400
45	1	00.414.100	Hose D.11
46	1	02.013.000	Plug
47	1	20.790.000	Drain Pipe L=585
48	1	40.266.000	Drain Plug M12 x 1.5
49	1	F0.008.016I	Clamp
50	1	20.792.000	Hose D.11

MAIN DRIVE PULLEY ASSEMBLY & CLUTCH

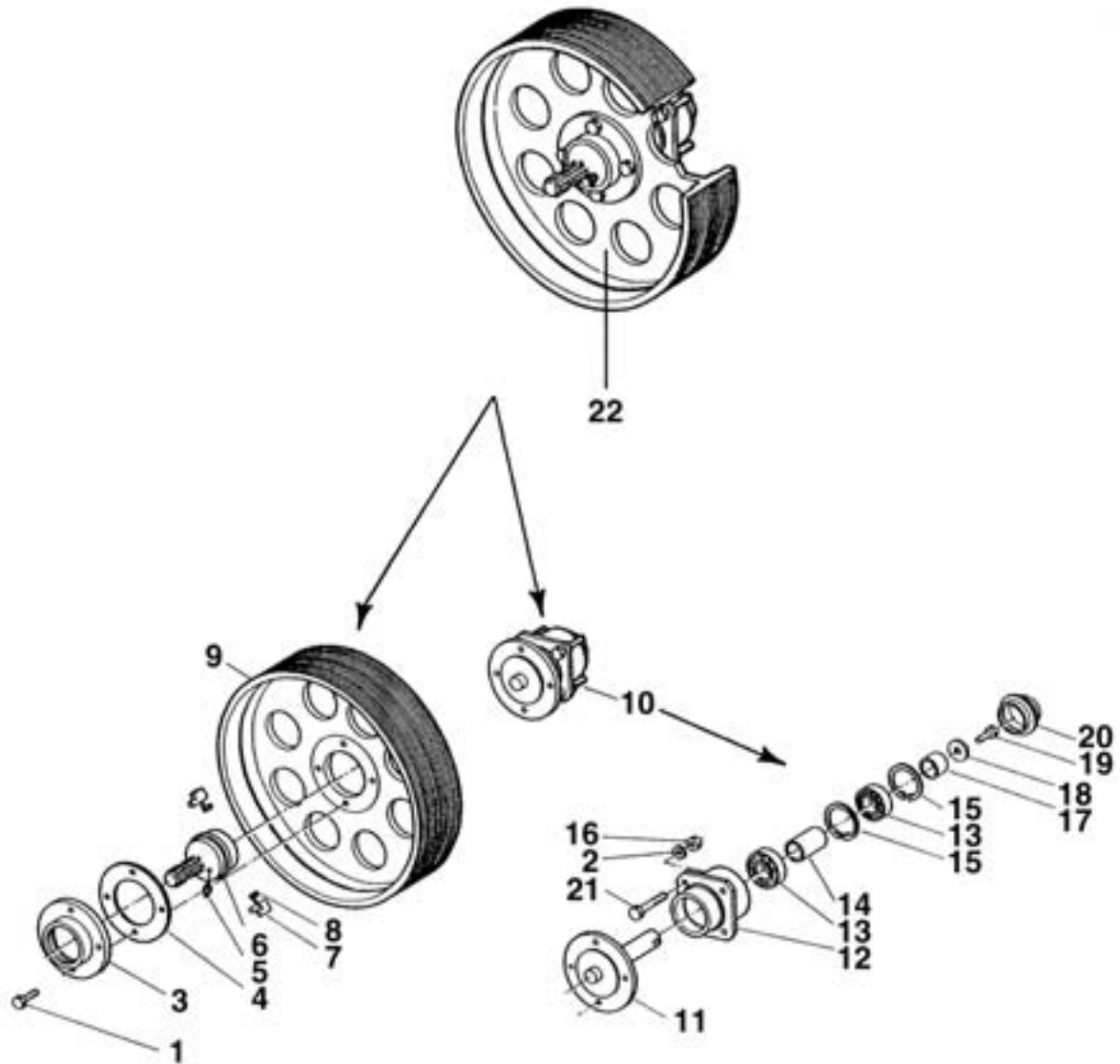

MAIN DRIVE PULLEY ASSEMBLY & CLUTCH

<u>REF#</u>	<u>QTY.</u>	<u>PART NO.</u>	<u>DESCRIPTION</u>
1	4	TE.012.050F	Bolt TE M12 x 50
2	4	RP.012.036	Washer D.12 x 36
3	1	04.066.000	Housing
4	1	04.719.000	Gasket
5	1	ID.010.001	Grease Nipple M10
6	1	03.701.000	Ratchet Clutch
7	2	02.502.002	Key
8	2	02.502.001	Spring
9	1	00.480.J50	Pulley
10	1	05.632.01C	Support Assembly
11	1	04.589.000	Shaft
12	1	05.632.000	Housing
13	1	6306-2RS	Bearing
14	1	04.565.000	Spacer Bar
15	2	IO.072.000	Internal Circlip D.72
16	4	DO.10.5587G	Nut
17	1	04.590.000	Spacer
18	1	20.810.000	Washer
19	1	TE.012.025FT	Bolt M12 x 25
20	1	04.555.001	Hub Cover
21	4	TE.012.090	Bolt M12 x 90
22	1	05.632.02C	Clutch & Pulley Support Assembly

FAN SUPPORT

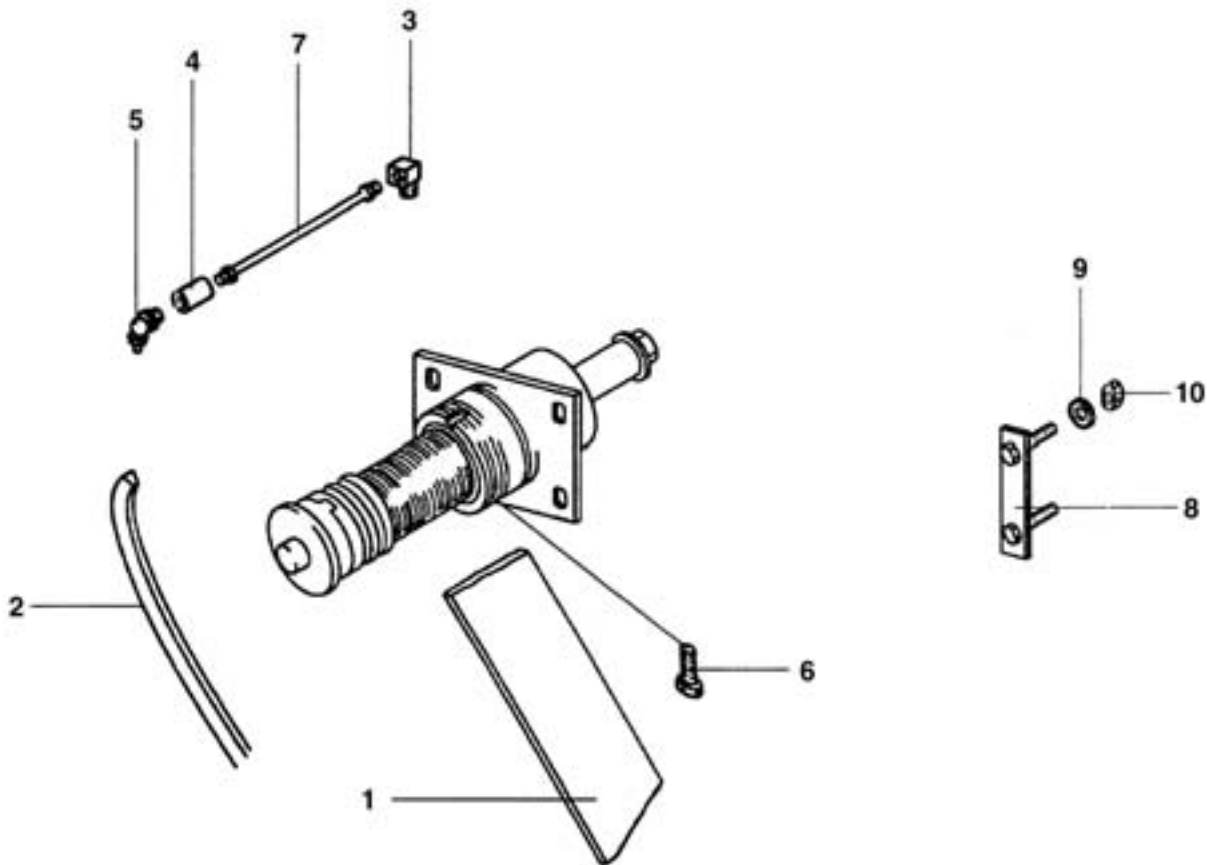

<u>REF#</u>	<u>QTY.</u>	<u>PART NO.</u>	<u>DESCRIPTION</u>
1	1	C0.690.J50	Drive Belt
2	1	C0.500.03V	V-Belt 3V500
3	1	02.736.000	90° Fitting Belt Idler
4	1	02.737.000	Nipple
5	1	IS.010.001	Grease Zerk
6	4	TE.010.060T	Bolt M10 x 60
7	1	02.738.040	Extension M10 x 1 x 400
8	2	02.945.000	Bolt Clamp
9	4	RP.012.036	Washer D.12 x 36
10	4	DO.12.5587G	Nut M12

LIQUID FLOW PATH



MAIN PUMP LIQUID FLOW PATH

<u>REF#</u>	<u>QTY.</u>	<u>PART NO.</u>	<u>DESCRIPTION</u>
1	12	FO.025.040I	Clamp D.25/40
2	1	20.112.000	Pocket
3	1	20.107.000	Bracket, Support
4	As Req'd	02.211.000	Hose D.16 Per Foot
5	1	20.808.000	Plug
6	1	02.470.000	Cover
7	2	00.055.037	Hosetail 90° D.25
8	2	00.058.004	Hosetail 90° D.30
9	1	02.339.000	Hosetail 45° D.30
10	4	RP.008.024	Washer D.8 x 24
11	1	20.424.100	Bracket
12	2	TE.008.120	Bolt M8 x 120
13	4	RP.008.000	Washer D.8
14	2	TE.008.025T	Bolt M8 x 25
15	1	00.493.000	Plastic Nut 1-1/4" Gas
16	4	00.058.006	Plastic Nut 1-1/4"
17	2	00.055.242	Plastic Nut 1" Gas
18	1	02.274.000	Tee
19	2	00.458.000	Elbow F/M
20	2	00.055.045	Plastic Nut 3/4" Gas
21	As Req'd	02.219.000	Hose D.25 Per Foot
22	2	02.349.000	Gasket
23	2	OR.000.511	O-Ring D.42 x 3.5
24	As Req'd	02.238.000	Hose D.30 Per Foot
25	5	OR.003.112	O-Ring D.28.24 x 2.62
26	2	F0.023.035I	Clamp D.23/35
27	1	OR.003.106	O-Ring D.26.64 x 2.62
28	3	02.374.000	Reducer 1" F/1-1/4" M
29	1	02.293.000	Reducer
30	2	02.030.010	Gasket
31	2	02.182.000	Cap
32	2	00.465.000	Elbow D.30
33	2	OR.000.132	O-Ring 23.81 x 2.62
34	3	00.045.012	Nipple 1-1/4"
35	1	OR.000.112	O-Ring 9.92 x 2.62
36	2	00.058.028	Nipple
37	7	OR.004.118	O-Ring 29.75 x 3.53
38	1	OR.000.507	O-Ring 27 x 5
39	1	02.445.000	Gauge
40	1	02.447.000	Regulator Valve

MAIN PUMP LIQUID FLOW PATH

<u>REF#</u>	<u>QTY.</u>	<u>PART NO.</u>	<u>DESCRIPTION</u>
41	1	02.450.010	Filter Assembly
42	1	02.422.000	Elbow, Male
43	1	24.058.000	Ball Valve
44	2	00.055.046	Elbow
45	As Req'd	02.215.000	Hose D.30 Per Foot
46	4	F0.016.025I	Clamp D.16/25
47	6	D0.08.5588G	Nut M8

AGITATION PUMP FLOW PATH

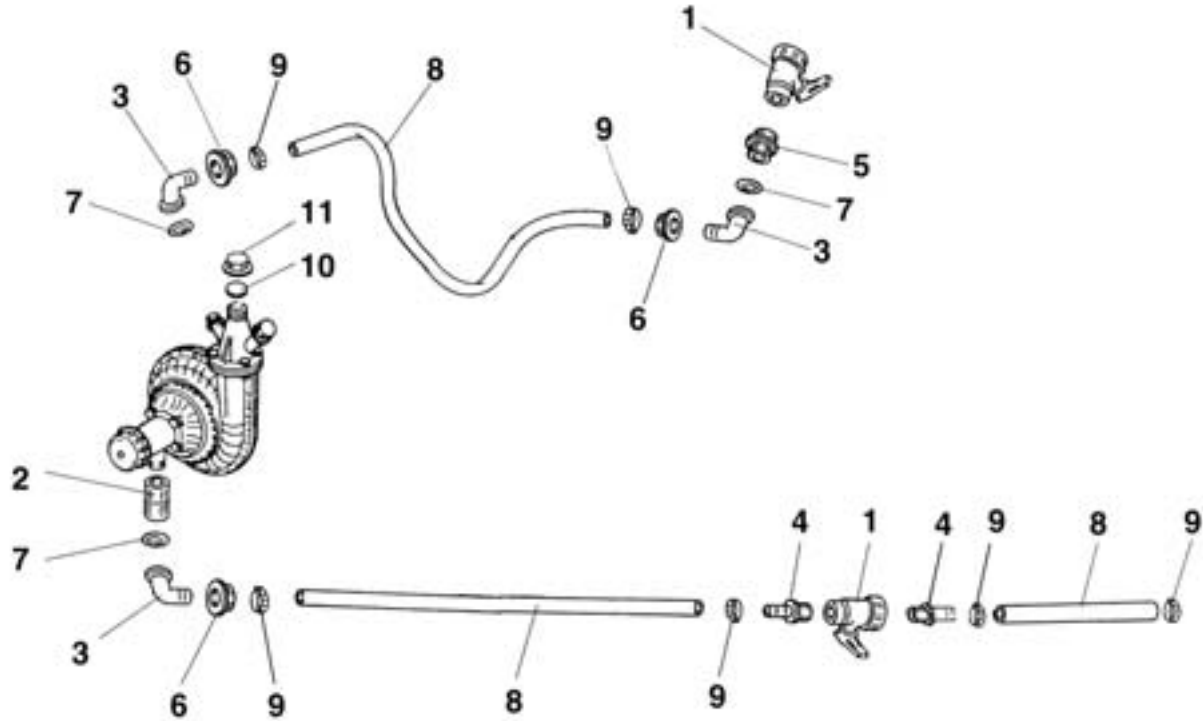

<u>REF#</u>	<u>QTY.</u>	<u>PART NO.</u>	<u>DESCRIPTION</u>
1	2	04.109.000	Ball Valve
2	1	02.384.000	Reducer
3	3	00.055.037	Elbow
4	2	02.403.000	Hose Nipple
5	1	00.055.034	Nipple
6	3	00.055.242	Nut
7	3	OR.000.132	O-Ring 23.81 x 2.62
8	As Req'd	02.219.000	Hose D.25 Per Foot
9	6	F0.023.035I	Clamp
10	1	24.100.000	Gasket
11	1	TF.001.000	Cap

INLINE FILTER ASSEMBLY 02.450.010

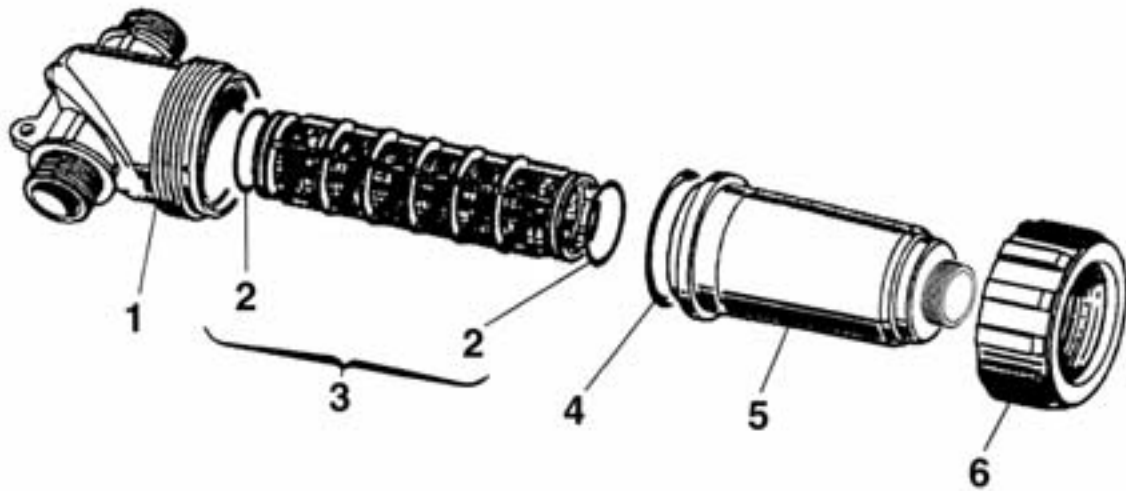

<u>REF#</u>	<u>QTY.</u>	<u>PART NO.</u>	<u>DESCRIPTION</u>
1	1	02.450.001	Body
2	2	OR3969353	O-Ring D.39.69 x 3.53
3	1	326003.030	Cartridge 50 Mesh (Blue)
3	Optional	326002.030	Cartridge 32 Mesh (White)
4	1	OR7463533	O-Ring D.74.63 x 5.33
5	1	02.450.011	Bowl
6	1	02.450.003	Back Nut
7	1	02.030.000	Gasket, Drain Cap (not shown)
8	1	02.182.000	Drain Cap (not shown)

SHOWER HEAD ASSEMBLY

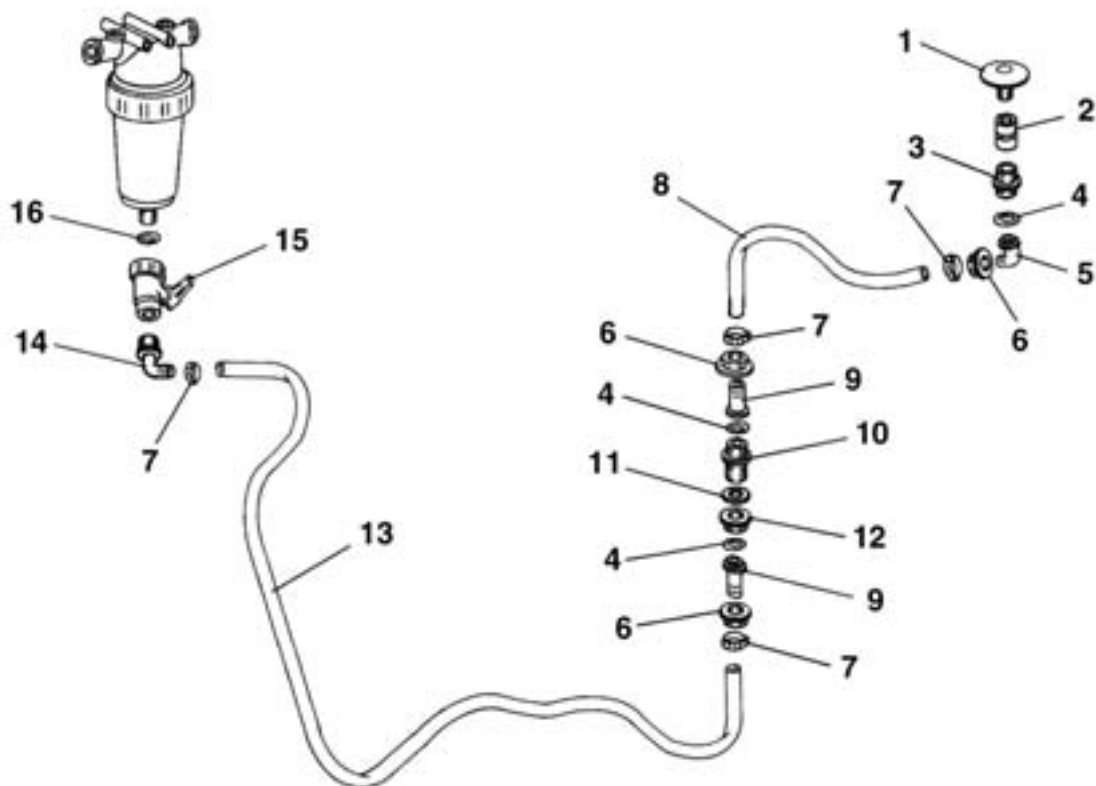

<u>REF#</u>	<u>QTY.</u>	<u>PART NO.</u>	<u>DESCRIPTION</u>
1	1	00.131.000	Anti-Swirl Intake
2	1	00.373.000	Adapter
3	1	00.055.034	Nipple
4	3	OR.000.132	O-Ring 23.81 x 2.62
5	1	00.055.037	Elbow D.25
6	3	00.055.242	Plastic Nut
7	4	F0.023.035I	Clamp D.23/35
8	1	20.821.100	Hose D.25 L=1000
9	2	00.055.021	Hose Barb D.25
10	1	2502051	Nipple 1" H=50/24
11	1	02.066.000	Gasket 33 x 45 x 3
12	1	00.542.000	Plastic Nut
13	1	20.770.200	Hose D.25 L=2000
14	1	20.795.000	Elbow
15	1	02.395.000	Ball Valve
16	1	OR.000.134	O-Ring 25.8 x 3.53

PUMP & TENSION PULLEY ASSEMBLY

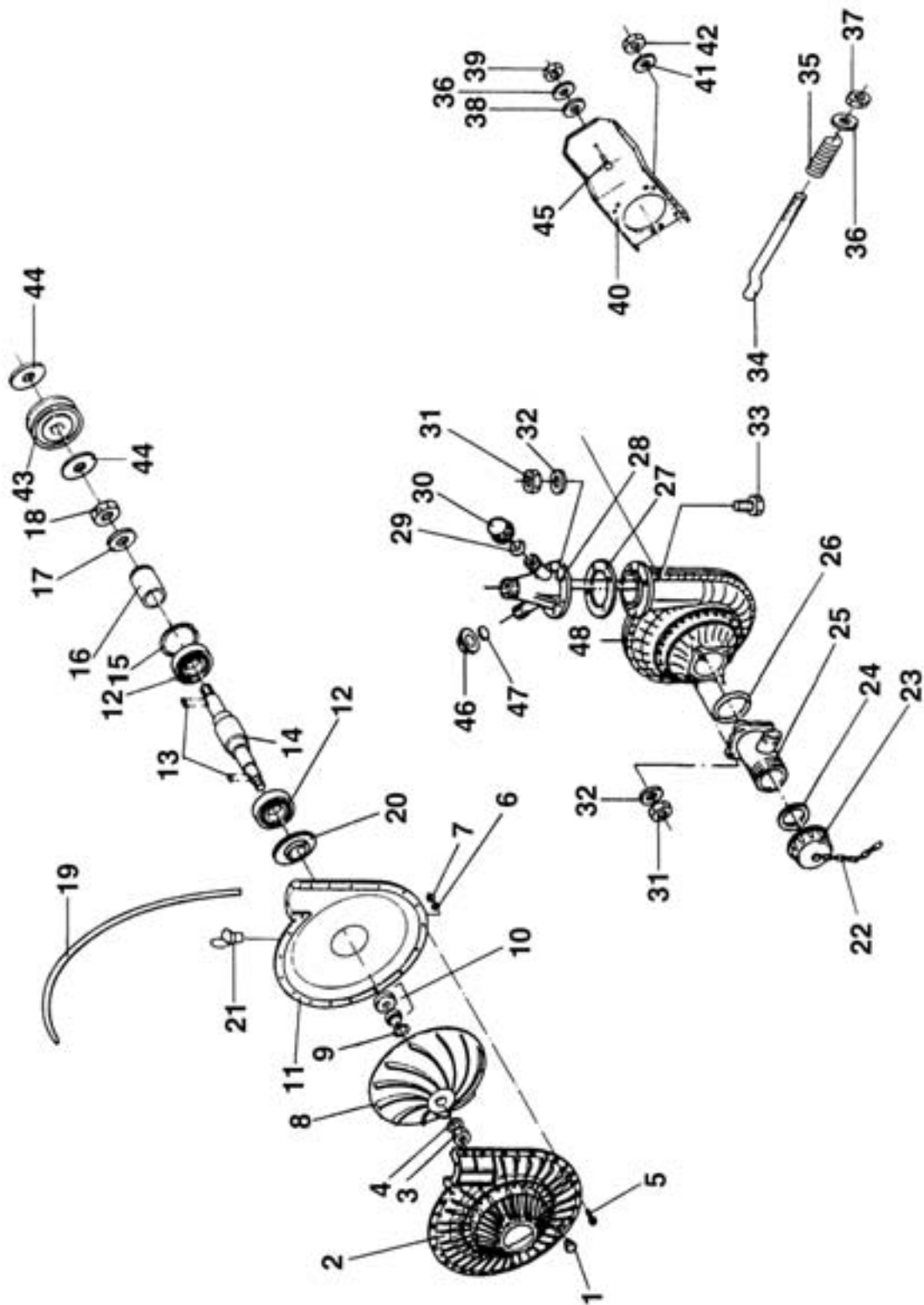

PUMP & TENSION PULLEY ASSEMBLY

<u>REF#</u>	<u>QTY.</u>	<u>PART NO.</u>	<u>DESCRIPTION</u>
1	2	TM.010.015	Plug 10 x 1.5
2	1	02.152.010	Housing, Front Half
3	1	DOT.10.5587	Brass Nut M10
4	1	RP.010.00I	Washer D.10 INCX
5	17	TC.05.25.85	Screw M5 x 25
6	17	RP.005.000	Washer D.5
7	17	DOT.05.5587	Brass Nut M5
8	1	02.153.000	Impeller
9	1	02.114.000	Washer
10	1	00.085.024CS	Pump Seal Kit
11	1	02.151.010	Housing Back Half
12	2	6303-2RS	Bearing
13	2	L.05.05.10	Key 5 x 5 x 10
14	1	02.155.010	Shaft
15	1	IO.047.000	Circlip I.47
16	1	02.722.000	Bushing
17	1	RP.010.030	Washer D.10 x 30
18	1	DO.10.5588G	Nut M10
19	1	OR.C02.070	O-Ring CORD D.2 L=700
20	1	20.406.000	Cover
21	1	02.473.000	Oil Feeder M8
22	1	04.111.022	Chain L=220
23	1	02.120.000	Cap, Drain
24	1	02.130.000	Gasket
25	1	02.116.000	Two Way Tap
26	1	OR.003.181	O-Ring
27	1	02.179.000	Gasket
28	1	02.113.000	Three Way Tap
29	1	02.265.000	Gasket D.29 x 3
30	1	TF.001.000	Cap
31	8	DOT.06.5587	Brass Nut M6
32	8	RP.006.000	Washer D.6
33	4	TE.006.025T	Bolt M6 x 25
34	1	20.426.000	Rod, M12 Belt Stretcher
35	1	02.964.000	Spring

PUMP & TENSION PULLEY ASSEMBLY

<u>REF#</u>	<u>QTY.</u>	<u>PART NO.</u>	<u>DESCRIPTION</u>
36	2	RP.012.000	Washer D.12
37	1	DOT.12.5587	Brass Nut M12
38	1	MT.012.000	Belleville Washer D.12
39	1	DA.012.0AG	Nut M12 x 1.75
40	1	02.978.000SX	Bracket
41	3	RP.008.024	Washer D.8 x 24
42	3	DO.08.5588G	Nut M8
43	1	02.723.002	Pulley D.82 x 1 3V
44	2	02.723.001	Washer, 3mm Pulley
45	1	TE.012.040T	Bolt M12 x 40
46	1	TF.012.000	Cap
47	1	OR.000.117	O-Ring D.13.1 x 3.6
48	1	02.157.050	Pump Assembly

MANUALLY OPERATED VALVE

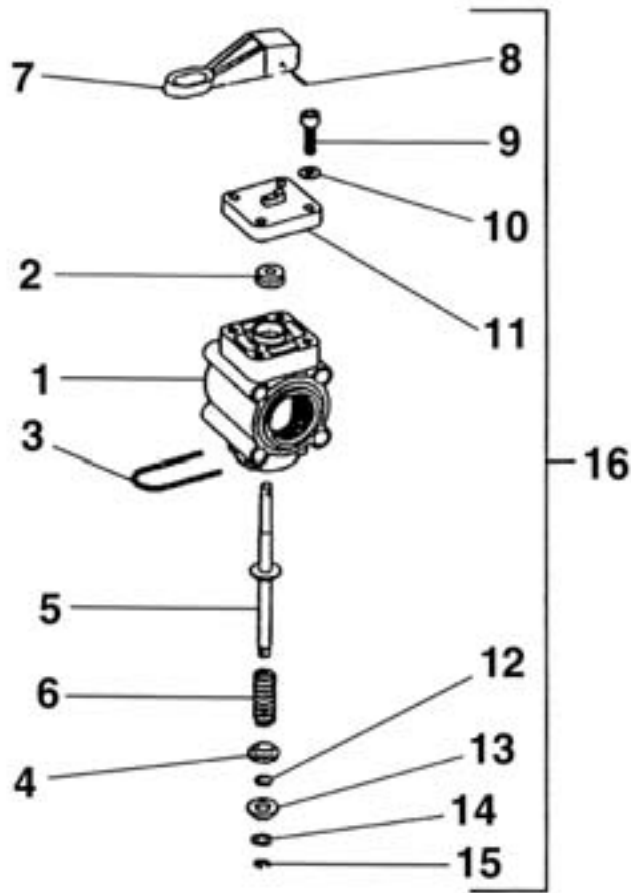

<u>REF#</u>	<u>QTY.</u>	<u>PART NO.</u>	<u>DESCRIPTION</u>
1	1	02.390.007	Body
2	4	02.390.008	Gasket
3	1	02.390.005	Clip
4	2	02.390.009	Cap
5	2	02.390.020	Pin
6	1	02.390.011	Spring
7	1	20.108.002	Lever For Manual Switch
8	1	SE.003.020	Spring Pin D.3 L=20
9	4	TCE.005.020	Cap Screw M5 L=20
10	4	RP.005.000	Washer D.5
11	1	02.390.021	Flange
12	1	02.390.016	O-Ring
13	1	02.390.015	Washer
14	1	02.390.014	Washer
15	1	02.390.013	Stop Ring
16	2	20.108.000	Valve, Manual Control

MANUAL COMMAND GROUP 2-WAY

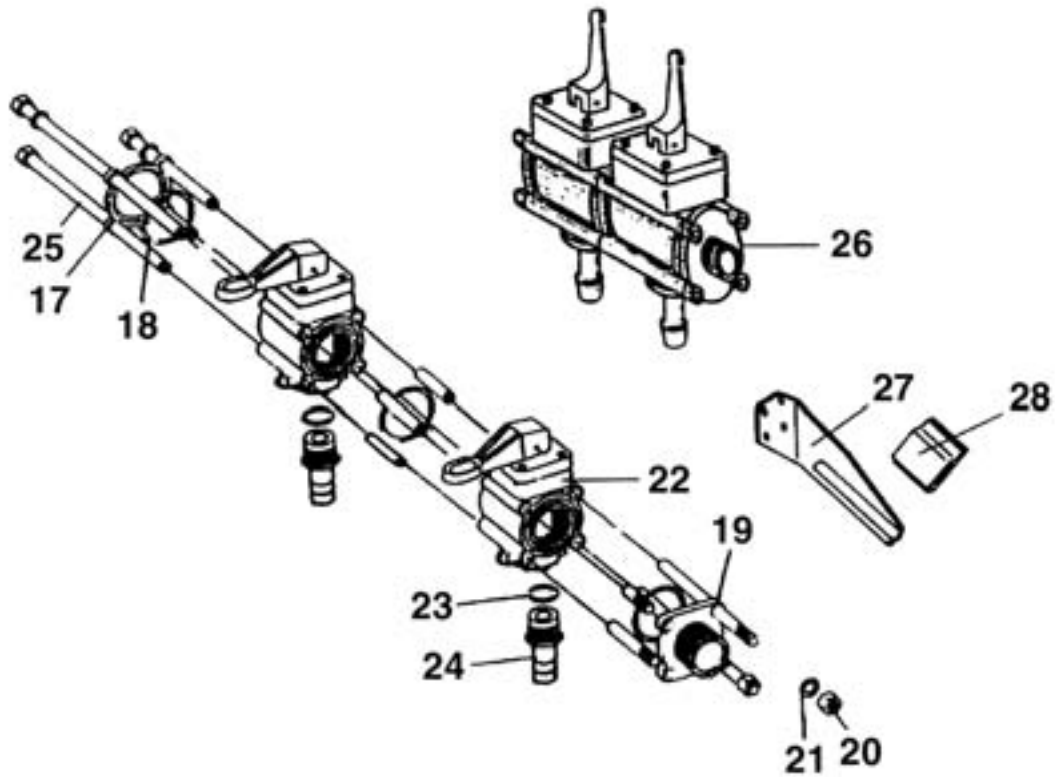

<u>REF#</u>	<u>QTY.</u>	<u>PART NO.</u>	<u>DESCRIPTION</u>
17	1	02.390.017	Seal Cap
18	3	OR.003.156	O-Ring
19	1	02.390.018	Connector
20	4	DO.08.5588G	Nut M8
21	8	RP.008.000	Washer D.8
22	2	20.108.000	Manually Operated Valve
23	2	OR.000.130	O-Ring
24	2	02.406.000	Nipple D.16
25	4	TCE.008.150	Bolt M8 x 150
26	4	20.108.01C	Manual Command Group Assembly
27	1	20.112.000	Bracket, Support
28	1	20.107.000	Pocket

OPTIONAL CONTROL BOX FOR SOLENOID VALVE

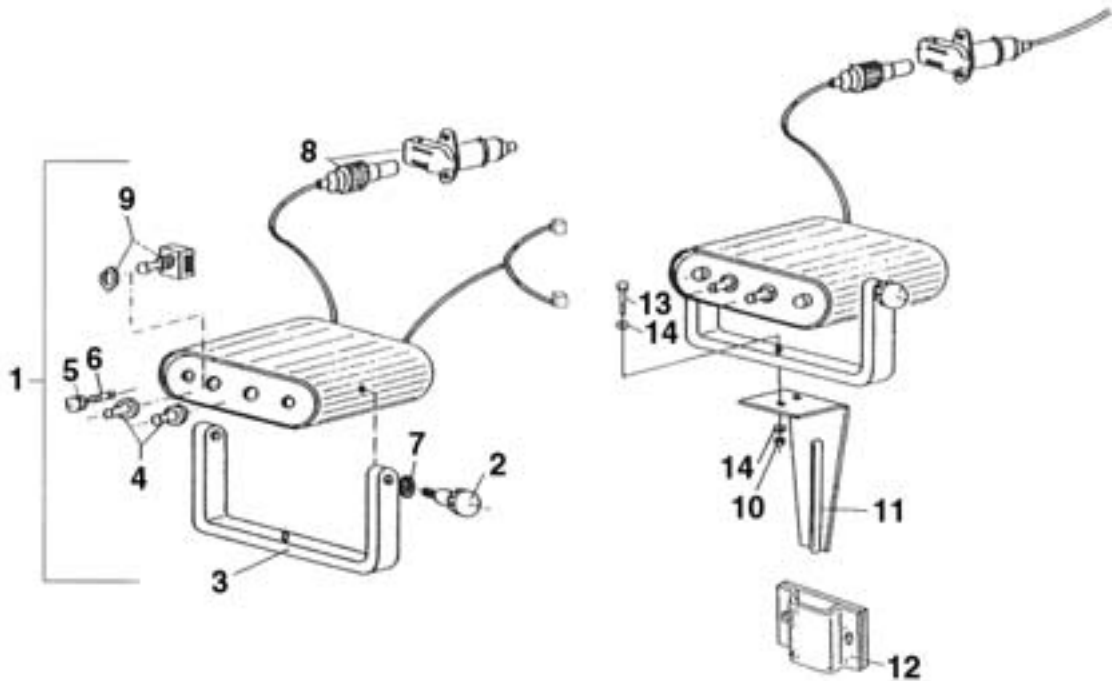

<u>REF#</u>	<u>QTY.</u>	<u>PART NO.</u>	<u>DESCRIPTION</u>
1	1	02.391.07C	Control Box Assembly L/Ref. 8
2	2	02.391.007	Knob, Bolt
3	1	02.391.006	Mounting Bracket for Box
4	2	02.391.001	Switch Cap
5	2	02.391.003	Panel Fuse Holder
6	2	02.391.004	Fuse 1.25 AMP
7	2	RD.006.000	Washer
8	1	02.391.005	Plug & Socket Kit
9	2	02.391.002	Double Pole Switch

KIT FOR CONTROL SOLENOID VALVE

10	1	DA.008.0AG	Nut
11	1	20.111.000	Mounting Bracket Electric Control
12	1	20.107.000	Support Control Assembly
13	1	TE.008.025T	Bolt
14	2	RP.008.024	Washer D.8 x 24

OPTIONAL SOLENOID CONTROL

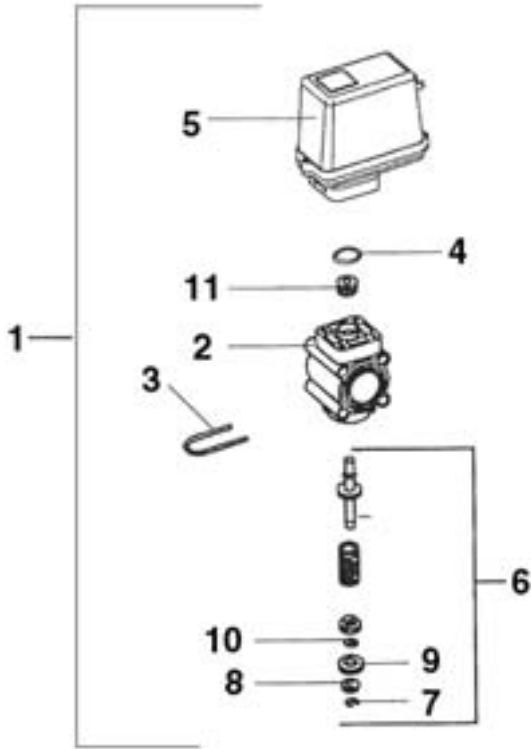

OPTIONAL SOLENOID COMMAND GROUP

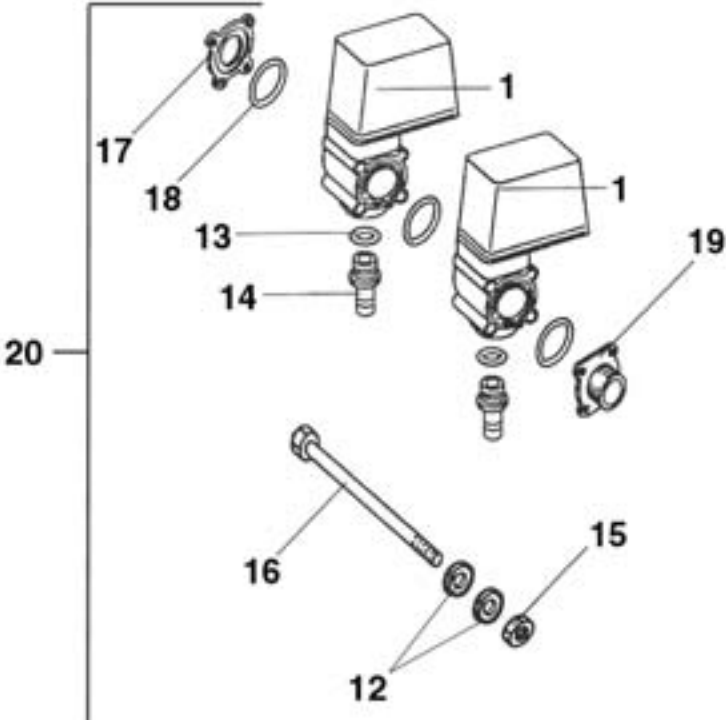

OPTIONAL SOLENOID CONTROL

<u>REF#</u>	<u>QTY.</u>	<u>PART NO.</u>	<u>DESCRIPTION</u>
1	1	02.390.029	Solenoid Valve
2	1	02.390.007	Body
3	1	02.390.005	Clip
4	1	OR.002.075	O-Ring D.18.77 x 1.78
5	1	02.390.028	Motor
6	1	02.390.027	Stem Assembly
7	1	02.390.013	Lock Clip
8	1	02.390.014	Washer
9	1	02.390.015	Washer
10	1	02.390.026	O-Ring
11	1	02.390.008	Gasket

OPTIONAL SOLENOID COMMAND GROUP

<u>REF#</u>	<u>QTY.</u>	<u>PART NO.</u>	<u>DESCRIPTION</u>
12	8	RP.008.000	Washer D.8
13	2	OR.000.130	O-Ring D.22.22 x 2.62
14	2	02.406.000	Hose Barb D.16
15	4	DO.08.5588G	Nut M8
16	4	TCE.008.150	Bolt M8 x 150
17	1	02.390.017	Flange
18	3	OR.003.156	O-Ring D.39 x 2.62
19	1	02.390.018	Connector
20	1	02.390.10C	Solenoid Command Group Assembly

DRIVELINE 7106086NNT077

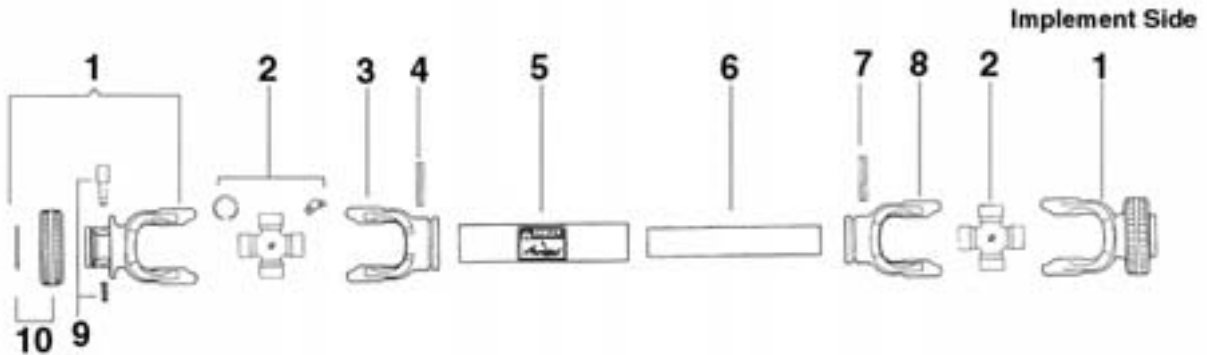

<u>REF#</u>	<u>QTY.</u>	<u>PART NO.</u>	<u>DESCRIPTION</u>
1	1	572060351	RS Collar Yoke 1-3/8 6-Spline
2	2	41206	Cross Kit Assembly #6
3	1	204066860	Outer Tube Yoke #6
4	1	341042000	Roll Pin O.T. #6
5	1	225690860	Outer Drive Tube #6
6	1	225110860	Inner Drive Tube #6
7	1	341043000	Roll Pin I.T. #6
8	1	204066852	Inner Tube Yoke #6
9	2	403000001	Quick Disconnect Pin Kit
10	2	240003051	RS Collar 5-6
11	1	572060351	RS Collar Yoke 1-3/8 6-Spline
	1	5F06086FF	Shield Kit With Bearings
	1	255060006	Shield Bearing Inner
	1	255060005	Shield Bearing Outer

LIMITED WARRANTY



GEARMORE, INC., warrants each new Gearmore product to be free from defects in material and workmanship for a period of twelve (12) months from date of purchase to the original purchaser. This warranty shall not apply to implements or parts that have been subject to misuse, negligence, accident, or that have been altered in any way.

Our obligation shall be limited to repairing or replacement of any part, provided that such part is returned within thirty (30) days from date of failure to Gearmore through the dealer from whom the purchase was made, transportation charges prepaid.

This warranty shall not be interpreted to render us liable for injury or damages of any kind or nature, direct, consequential or contingent, to person or property. This warranty does not extend to loss of crops, loss because of delay in harvesting or any other expenses, for any other reasons.

Gearmore in no way warrants engines, tires, or other trade accessories, since these items are warranted separately by these respective manufacturers.

Gearmore reserves the right to make improvements in design or changes in specification at any time, without incurring any obligations to owners or units previously sold.

GEARMORE, INC.
13477 Benson Ave.
Chino, CA 91710

Always refer to and heed machine operating warning decals on machine.

The serial number of this product is stored in our computer database, thus submitting a warranty registration card is not required.