



ROTARY MOWER

**Operation, Service
& Parts Manual For
L-96-C, P-96-C,
L-120-C & P-120-C**

February 2000

TABLE OF CONTENTS

Introduction	1
Set-up Instructions	2
Preparation & Training	3
Operational Safety	4-5
Maintenance Safety	6
Mower Safety Decals	7
General Maintenance	8
Troubleshooting	9
Mower Assembly	10-11
Blade Carrier	12
Gearbox Assembly	13
Triple Gearbox Assembly	14
Outer Gearbox Assembly	15-16
Driveline	17
Limited Warranty	18

Date of Purchase: _____

Model Number: _____

Serial Number _____

INTRODUCTION

We welcome you as an owner of a Gearmore mower. Please read the following instructions and refer to them when required:

BEFORE OPERATING YOUR MOWER

1. Inspect for damage and loose or missing parts. Make sure all fittings and drive components are secure.
2. Lubrication (*See Lubrication Section*).
3. Remove all large, foreign objects from area being mowed.

TO OPERATE MOWER

1. Connect mower to the tractor 3-point hitch lower link arms. (Make sure tractor and mower are on a level surface.)
2. Connect top link of tractor to mower and adjust turnbuckle so the mower is level with the ground.
3. Install driveshaft after making sure it is the correct length. (See separate warning sheet on the correct method of achieving the proper driveshaft length.)
4. Set height of tailwheel based on what height you want to cut. Example: The blades are set 1" above the skids. Thus, if you want a 2" cut, you would set tailwheel so skids are 1" above ground.

NOTE: The mower is designed to float on the tailwheel and mower 3-point hitch, so the mower should not be dragged on the ground.

5. Set height stops on the tractor 3-point lift so mower will not be raised higher than necessary. Failure to do this could cause damage by putting excessive angle on the driveshaft.
6. Engage the tractor PTO when tractor engine is at idle speed. Engaging the PTO with engine at full speed will reduce the life of the driveshaft. For most cutting operations, a ground speed of 3 to 5 MPH and PTO at full 540 RPM is recommended.

SET-UP INSTRUCTIONS

1. Your mower is equipped with a slip clutch. The following procedure should be followed:

Slip clutch unit onto gearbox input shaft and secure with lock ring that is provided. Grease pilot end of input shaft.

NOTE: Fasten these bolts securely.

2. Remove cover bolts to get to parts stored for shipping (ref. #16).
3. Remove lift arm braces (ref. #6), lift arms (ref. #10), PTO shaft (ref. #11), lift arm yokes (ref. #12) and swivel yoke (ref. #5).
4. As mower is assembled, leave all bolts hand-tightened until all parts are assembled.
5. Assemble lift cylinder push arm (ref. #8) to left plate with two (2) $\frac{3}{4}$ " x 2- $\frac{1}{2}$ " bolts.
6. Assemble two (2) lift arm yokes (ref. #12) to lift plates (left and right) with two (2) bolts. Use $\frac{3}{4}$ " x 2" bolt on inside of yoke and $\frac{3}{4}$ " x 2- $\frac{1}{2}$ " bolt on outside of yoke.
7. Assemble two (2) lift arms (ref. #10) to inside of lift plates with four (4) $\frac{3}{4}$ " x 2- $\frac{1}{2}$ " bolts.
8. Assemble two (2) lift arm braces to yoke of lift arms (ref. #10) with one (1) bolt $\frac{7}{8}$ " x 6", using spaces (3- $\frac{1}{8}$ " x 1" range).
9. Finish assembly, two lift arm braces (ref. #6) to rear lugs weld to rear deck with two (2) $\frac{3}{4}$ " x 2" bolts.
10. Tighten all bolts.
11. Leave top deck off until all parts are lubricated (see lubrication instructions, page 8).

PREPARATION



READ THIS BEFORE OPERATING MOWER



TRAINING

Know your controls and how to stop tractor engine and mower quickly in an emergency. ***READ THIS OPERATOR'S MANUAL AND THE MANUAL PROVIDED WITH YOUR TRACTOR.***

To avoid accident or injury, ***do not*** allow anyone to operate this equipment without proper instructions. Any person who operates this equipment must be instructed in and be capable of the safe operation of the unit, its attachments and all controls.

DO NOT allow children to operate machine, or adults to operate it without proper instructions.

BEFORE OPERATION

- ***Always*** wear relatively tight and belted clothing when operating mower. Loose clothing should not be worn, as it could get caught in the moving parts or controls. Wear sturdy, rough-soled work shoes and protective equipment for eyes, hands, hearing and head. ***Never*** operate tractor or implements in bare feet, sandals or sneakers.
- ***Never*** permit any person other than the operator to ride on board the tractor at any time. ***DO NOT*** allow riders on mower at any time.
- Clear area of stones, branches or other debris that might be thrown, causing injury or damage.
- Operate only in daylight or good artificial light.
- Ensure mower is properly mounted, adjusted and in good operating condition.
- Ensure all PTO and other safety shielding is properly installed and in good condition.

OPERATIONAL SAFETY

- Guards and safety shields are for *your* protection. **DO NOT** operate equipment unless they are in place.
- Read and observe **all safety decals** on the tractor and mower (see page7).
- **Always** operate tractor PTO (power take-off) at recommended RPM (revolutions per minute).
- Stay away from PTO shaft and mower when engaging PTO.
- Disengage tractor PTO and shift into neutral before attempting to start engine.
- **NEVER** allow anyone within 25' of machine while it is in operation.
- **DO NOT** stop or start suddenly when going uphill or downhill. Avoid operation on steep slopes.
- Be alert for holes in terrain and other hidden hazards. **Always** drive slowly over rough ground.
- Reduce speed on slopes and in sharp turns to prevent tipping or loss of control. Be careful when changing direction on slopes.
- Stop mower and tractor immediately upon striking an obstruction. Turn off engine, inspect mower and repair any damage before resuming operation.
- Disengage power to mower and stop engine before dismounting from tractor, before making any repairs or adjustments, transporting, or unclogging mower.
- Take all possible precautions when leaving tractor unattended. Disengage PTO, lower mower, shift into neutral, set parking brake, stop engine and remove key from ignition.

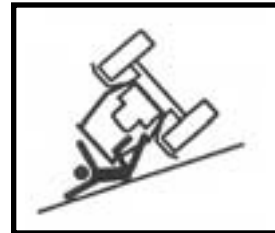

OPERATIONAL SAFETY

Continued...

- Front tractor weights or front tire ballast should be used to enhance front end stability on small tractors.

- **NEVER** operate mower in raised position.

- Check to make sure PTO is properly connected and that the driveline is correct to prevent bottoming out or pulling apart during the full lift range of the hitch.



- This implement is designed for a one-man operation. It is the responsibility of the tractor operator to see that no one is in the proximity of the implement when it is started. **DO NOT** operate the implement when another person is within 25' of the implement.

- **NEVER** put hands or feet under mower deck while tractor engine or mower is running.

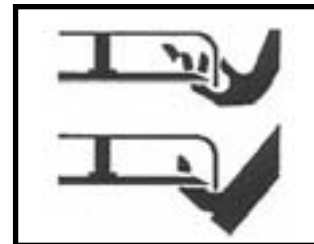

MAINTENANCE SAFETY

- Support the mower with safety stands or blocks before working beneath it.
- Follow good shop practices:

A. Keep service area clean and dry.



B. Be sure electrical outlets and tools are properly grounded.

C. Use adequate light for the job at hand.



- Use only tools, jacks and hoists of sufficient capacity for the job.
- **NEVER** work on the mower unless the tractor engine is off and the driveline is disconnected.
- **ALWAYS** wear heavy canvas or leather gloves when handling mower blades.
- **NEVER** wear loose or frayed clothing when working on moving parts. (i.e. gearbox, blade pan, driveline, etc.)
- Make sure all guards are in place and properly secured when all maintenance work is completed.

MOWER SAFETY DECALS

1. Keep all safety decals and signs clean and legible at all times.
2. Replace safety decals and signs that are missing or have become illegible. (Contact Gearmore at 909.548.4848 for *free* replacement safety decals.)

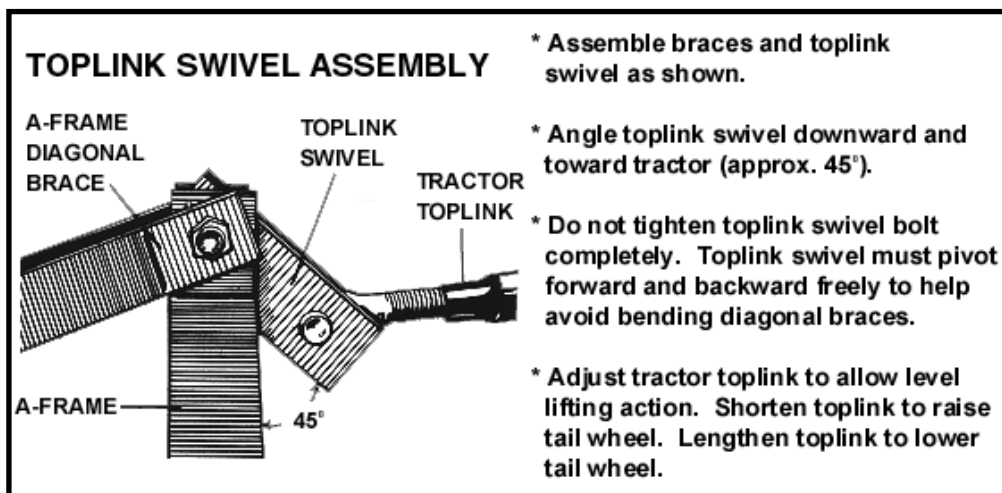

GENERAL MAINTENANCE

Carefully follow all instructions as stated in this manual. This includes operation, lubrication, safety and maintenance. This mower was designed and built for years of reliable service if properly cared for. However, rotary mowers are a high RPM machine, thus daily attention is required.

- ✓ Check all bolts for tightness.
- ✓ Check to make sure all safety guards are in place.
- ✓ Check to remove any trash build-up.
- ✓ Check lubrication - *see lubrication section.*
- ✓ Check blades to make sure they are securely fastened.

SERVICING BLADES

When replacing or grinding blades, both blades must be replaced or re-ground at the same time to maintain the proper balance in the mower. Gearmore mowers are equipped with special heat-treated alloy steel blades. Use only Gearmore blades, substitutes may be dangerous. **NEVER** try to straighten or weld blades.

LUBRICATION

DRIVESHAFT - The driveshaft must be lubricated before mower is put into use. After that, grease every **8 hours** of use or when required. It is also necessary, from time to time, to untelescope the driveshaft to clean and re-grease tubing.

GEARBOX - Check gearbox oil level through square headed screw plug. Add SAE 90 weight oil when required. Change gearbox oil after every **400 hours** of use.

TAILWHEEL - Grease every **8 hours** of use or when required.

TAILWHEEL PIVOT TUBE - Grease *weekly* or when required.

To comply with OSHA AG Guarding Standard #1928.27, the following guards and shields **must** be kept in place and in good working condition:

1. Safety chain shielding
2. Driveshaft shields
3. Guards over moving parts

BE CAREFUL AND ALWAYS THINK SAFETY FIRST!

TROUBLESHOOTING

PROBLEM	CAUSE	SOLUTION
Excessive vibration	Blades are not free to swing.	Check bushings and movements of blades.
	Blades are out of balance.	Check blades for damage or replace.
Unusual noise	Loose blade bolts or worn bushings.	Tighten blade bolts, check bushings for wear and change as needed.
	Bent blade carrier, blades striking deck.	Replace blade carrier.
	Deck bent causing blades to hit.	Straighten deck.
	Gearbox low of oil.	Check seals in gearbox and fill to proper level.
Poor cutting	Not maintaining proper PTO speed.	Check PTO with tachometer and operate at proper RPM.
	Improperly adjusted.	Adjust according to Operators Manual.
	Forward speed too fast.	Coordinate forward speed with blade speed.
	Dull blades.	Sharpen blades.
PTO turns and blades do not	Gears stripped in gearbox.	Replace or repair gearbox.
	Shear bolt sheared.	Replace shear bolt.
PTO will not telescope	Improper lubrication.	Separate and fill female tube half full of grease.
	PTO twisted.	Replace twisted portion.
	Bent PTO.	PTO too long. Size to tractor according to manual.
	Shields damaged.	Replace.
PTO twisted	Over torqued.	Caution operator not to ground out machine.
	Not maintaining correct PTO speed.	Maintain proper PTO speed.
Machine streaking	Cutting too high, leaving wheel tracks.	Cut lower and slow forward speed down.
	Not maintaining proper RPM speed.	Maintain proper RPM speed.

MOWER ASSEMBLY L-96-C & L-120-C

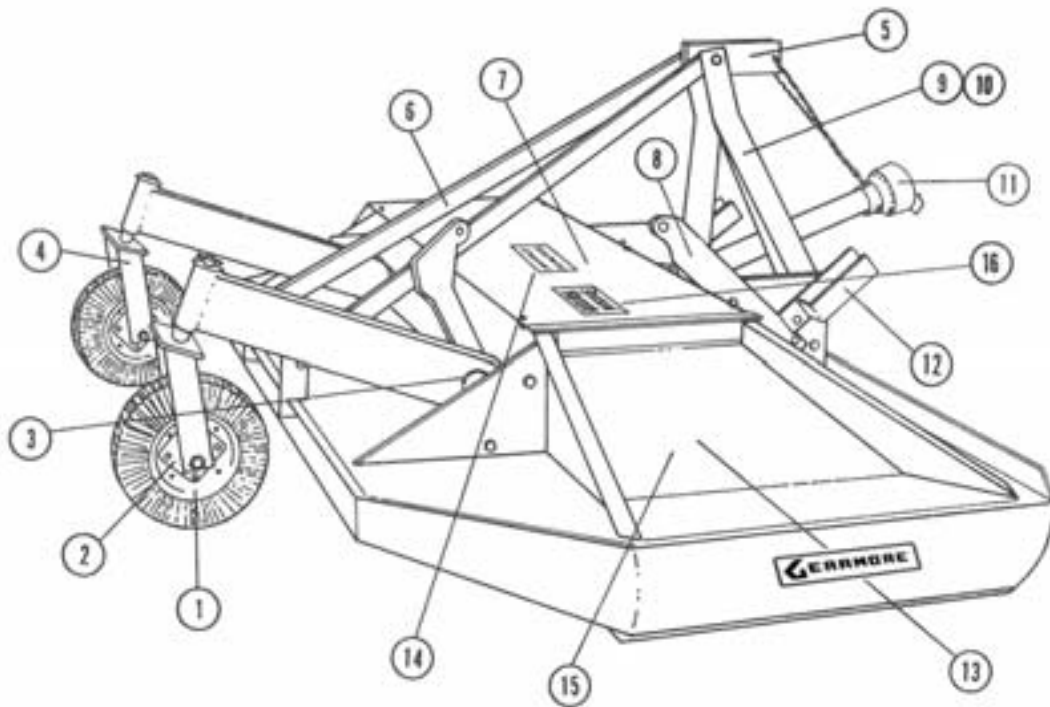

<u>REF#</u>	<u>QTY.</u>	<u>PART NO.</u>	<u>DESCRIPTION</u>
1	2	403001	Tire and Rim
2	2	191100	Wheel Hub
3	1	403570	Cross Axle Assy. L-96-C
3	1	403571	Cross Axle Assy. L-120-C
4	2	403021	Wheel Fork Assembly
5	2	403401	Swivel Yoke
6	2	310839	Lift Arm Braces L-96-C
6	2	310609	Lift Arm Braces L-120-C
7	2	190300	Left Cutting Blade L-96-C
7	2	190302	Left Cutting Blade L-120-C
8	1	310802	Lift Cylinder Push Arms
9	1	403659	Right Lift Arm Assembly
10	1	403660	Left Lift Arm Assembly
11	1	147134	PTO Shaft, Slip Clutch
12	2	403425	Lift Arm Yoke
13	2	190301	Right Cutting Blade L-96-C
13	2	190303	Right Cutting Blade L-120-C
14	1	114045	Safety Decal
15	2	403037	Blade Carrier L-96-C
15	2	403039	Blade Carrier L-120-C
16	1	114025	Structural Decal

MOWER ASSEMBLY P-96-C & P-120-C

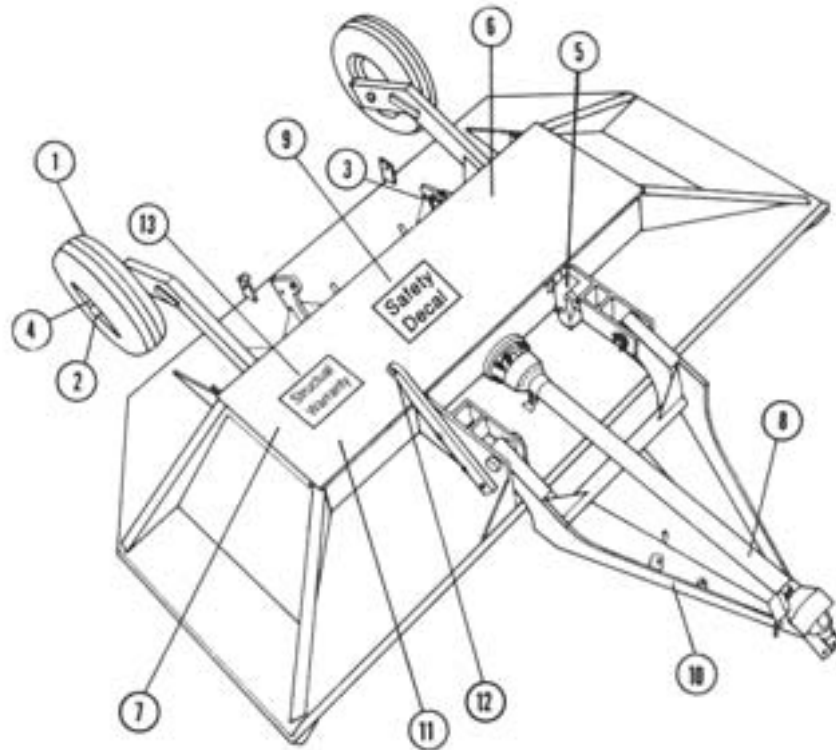

<u>REF#</u>	<u>QTY.</u>	<u>PART NO.</u>	<u>DESCRIPTION</u>
1	2	192300	Tire and Rim
2	2	149050	Wheel Spindle
3	1	403573	Cross Axle Assembly P-96-C
3	1	403572	Cross Axle Assembly P-120-C
4	2	191050	Wheel Hubs
5	1	131075	Cable Assembly
6	2	190300	Left Cutting Blades P-96-C
6	2	190302	Left Cutting Blades P-120-C
7	2	190301	Right Cutting Blades P-96-C
7	2	190303	Right Cutting Blades P-120-C
8	1	147260	PTO Shaft, Slip Clutch/C.V.
9	1	114045	Safety Decal
10	1	403653	Pull Tongue Assembly P-96-C
10	1	403654	Pull Tongue Assembly P-120-C
11	2	403037	Blade Carrier P-96-C
11	2	403039	Blade Carrier P-120-C
12	2	310802	Lift Cylinder Push Arms
13	1	114025	Structural Decal

CRITICAL BLADE CARRIER POSITIONS

CRITICAL POSITIONS OF BLADE CARRIERS
FOR 8' AND 10' ROTARY MOWERS
WHEN MOWER IS TILTED TOWARD TRACTOR

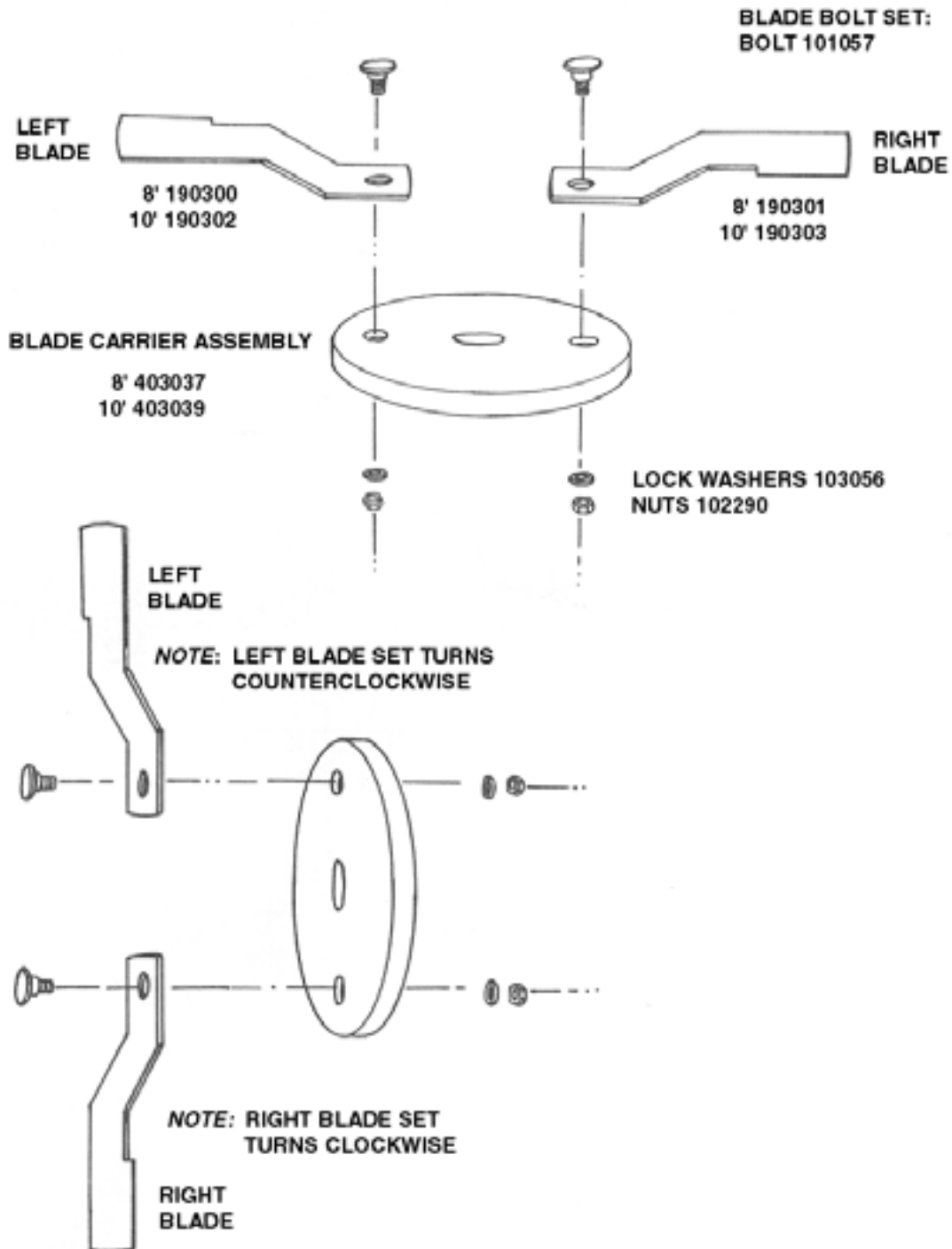

GEARBOX ASSEMBLY

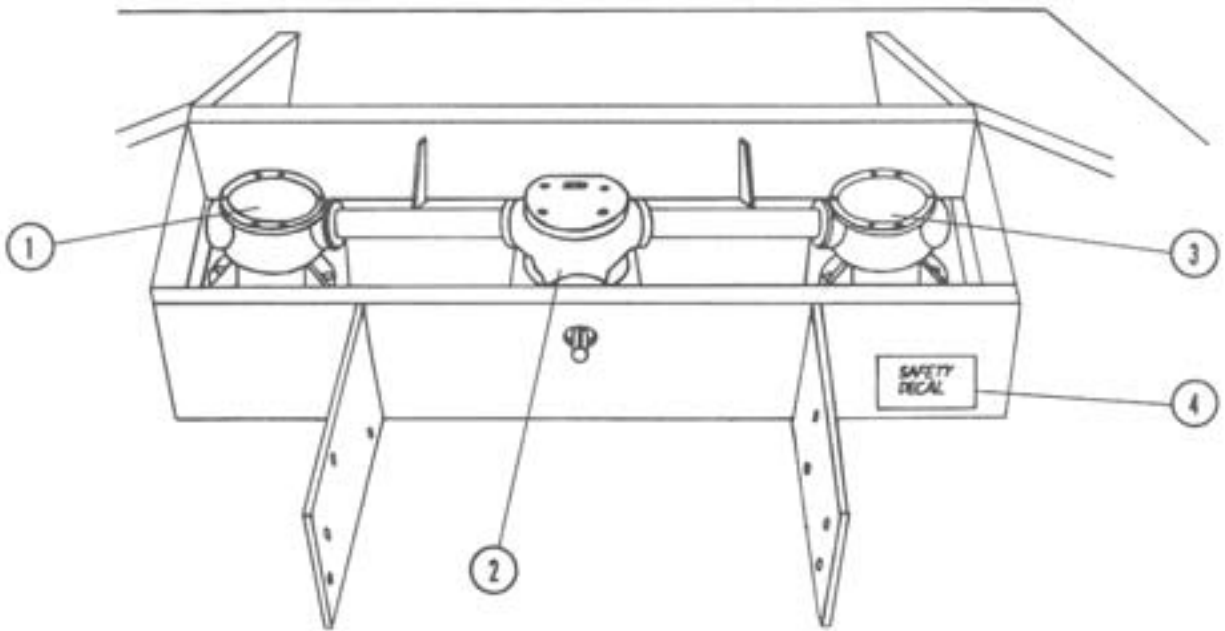

<u>REF#</u>	<u>QTY.</u>	<u>PART NO.</u>	<u>DESCRIPTION</u>
1	1	184035	Outer Gear Box L-96-C & P-96-C
1	1	184040	Outer Gear Box L-120-C & P-120-C
2	1	184061	Triple Gear Box L-96-C & P-96-C
2	1	184062	Triple Gear Box L-120-C & P-120-C
3	1	184035	Outer Gear Box L-96-C & P-96-C
3	1	184040	Outer Gear Box L-120-C & P-120-C
4	1	114045	Safety Decal

TRIPLE GEARBOX ASSEMBLY

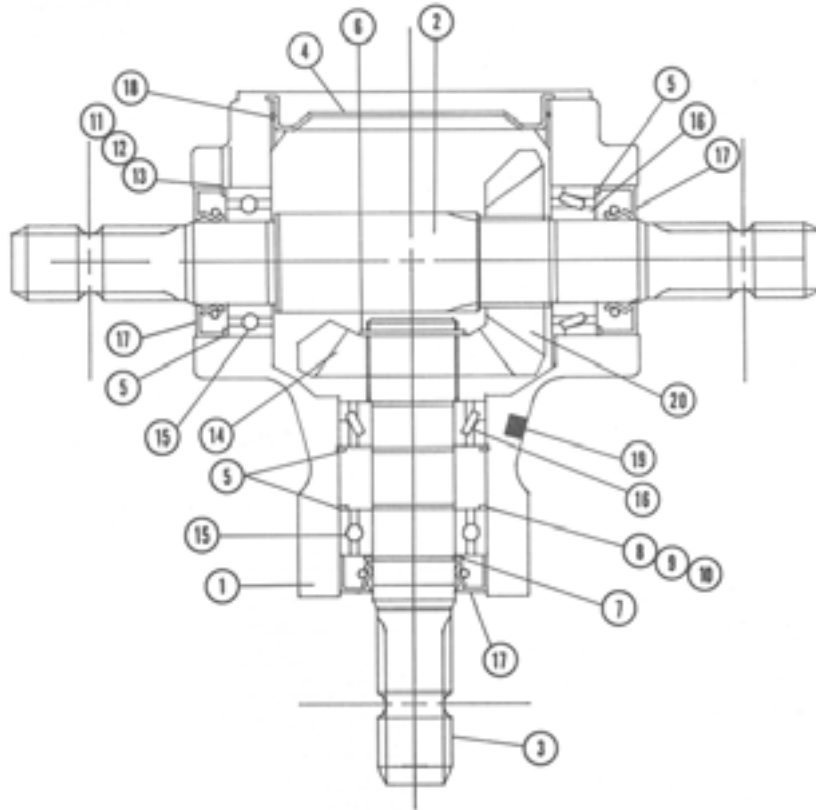

<u>REF#</u>	<u>QTY.</u>	<u>PART NO.</u>	<u>DESCRIPTION</u>
1	1	129036	Housing
2	1	186050	Output Shaft
3	1	186045	Input Shaft
4	1	131135	Cover
5	4	106026	Snap Ring-Bearings Retainer
6	1	106145	Snap Ring-Input Shaft, Lg. End
7	1	106140	Snap Ring-Input Shaft, Sm. End
8	As Req'd	124125	Gasket 0.3mm
9	As Req'd	124127	Gasket 0.15mm
10	As Req'd	124129	Gasket 0.1mm
11	As Req'd	124122	Gasket 0.6mm
12	As Req'd	124123	Gasket 0.8mm
13	As Req'd	124124	Gasket 1.0mm
14	1	185045	Input Gear (19T)M6.6
15	2	155310	Ball Bearing (6208)
16	2	155315	Tapered Bearing (30208)
17	3	156065	Oil Seal - Shaft
18	1	124255	Oil Seal - Cover
19	1	131038	Pipe Plug 3/8"
20	1	185040	Bevel Gear - Output (15T)M6.6

OUTER GEARBOX ASSEMBLY

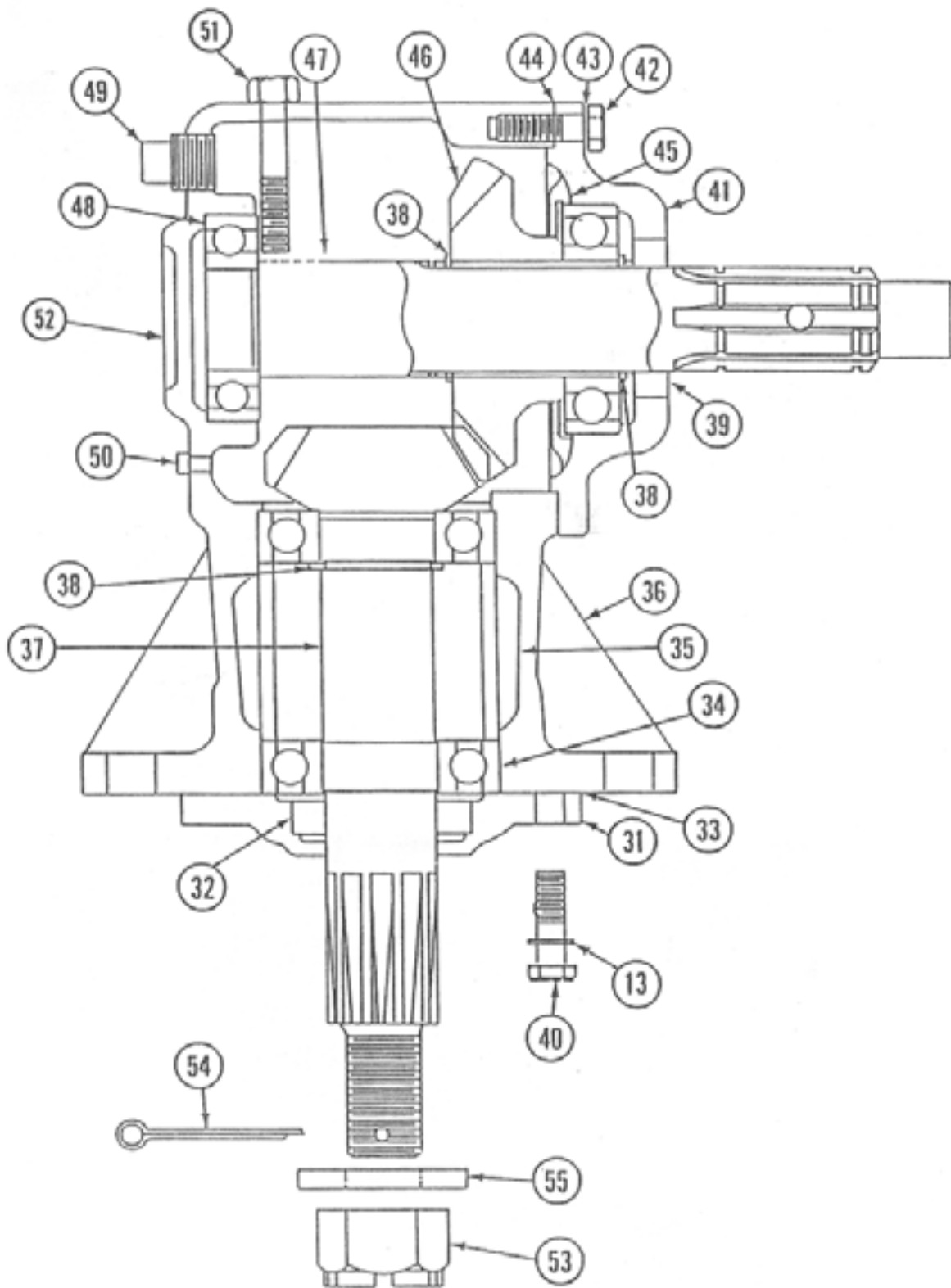

OUTER GEARBOX ASSEMBLY

<u>REF#</u>	<u>QTY.</u>	<u>PART NO.</u>	<u>DESCRIPTION</u>
31	1	129005	Bearing Retainer (Casting)
32	1	156005	Oil Seal, Output
33	1	124131	Bottom Cap Housing Gasket
34	2	155005	Bearing Output Shaft
34	1	155005	Bearing Input Shaft (Hoover 208)
35	1	131045	Spacer
36	1	129010	Housing, Main (Casting)
37	1	185005	Output Pinion Gear
38	3	131055	Retainer Ring 15M
39	1	156010	Oil Seal, Input
40	4	101116	3/8" x 1-1/4" Capscrew
41	1	129015	Side Housing (Casting)
42	6	101112	3/8" x 1" Capscrew
43	10	103110	3/8" Lockwasher
44	1	124130	Input Side Housing Gasket
45	1	131030	Retainer Ring
46	1	185010	Input Gear
47A	1	186005	Input Shaft, Spline
47B	1	186016	Input Shaft, (Shear Bolt Type)
48	1	155010	Bearing, Input Shaft, Rear (6207)
49	1	131035	Pipe Plug (1/2 - 14 NPT)
50	1	131040	Pipe Plug (1/8 - 27 NPT)
51	1	131145	Oil Dip Stick
52	1	131140	Inspection Cap
53	1	102284	Castle Nut - Metric
54	1	105001	3/16" x 2" Cotter Pin, ZP
55	1	104029	Washer - Output Shaft

PTO DRIVELINE 147248

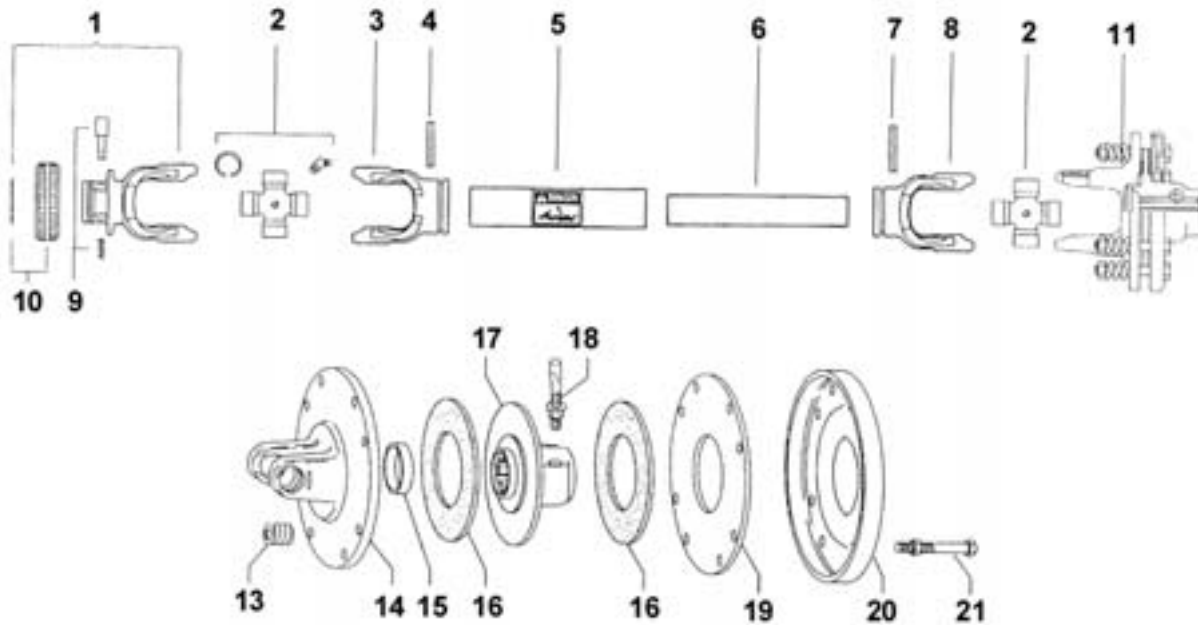

<u>REF#</u>	<u>QTY.</u>	<u>PART NO.</u>	<u>DESCRIPTION</u>
1	1	572050351	Yoke 1-3/8" 6 Spline
2	2	41205	Cross Journal Kit #5
3	1	204056860	Yoke, Outer Tube
4	1	341053000	Roll Pin O.T.
5	1	125121200	Tube, Outer Drive
6	1	125091200	Tube, Inner Drive
7	1	341002000	Roll Pin I.T.
8	1	204056861	Yoke, Inner Tube
9	1	403000001	Pin Kit
10	1	240003051	RS Collar Kit
11	1	638248004	Slip Clutch Assembly FF-2
12	1	5F06120F1	Complete Shield (not shown)
13	8	351013370	Spring 7mm
14	1	253052101	Flanged Yoke
15	1	258005320	Bushing
16	2	247000061	Lining 160mm
17	1	515210311	Hub 1-3/8" 6 Spline
18	1	408000060	Threaded Bolt Assembly
19	1	248230002	Pressure Plate
20	1	248230006	Cover
21	8	432000006	Bolt & Nut

LIMITED WARRANTY



GEARMORE, INC., warrants each new Gearmore product to be free from defects in material and workmanship for a period of twelve (12) months from date of purchase to the original purchaser. This warranty shall not apply to implements or parts that have been subject to misuse, negligence, accident, or that have been altered in any way.

Our obligation shall be limited to repairing or replacement of any part, provided that such part is returned within thirty (30) days from date of failure to Gearmore through the dealer from whom the purchase was made, transportation charges prepaid.

This warranty shall not be interpreted to render us liable for injury or damages of any kind or nature, direct, consequential or contingent, to person or property. This warranty does not extend to loss of crops, loss because of delay in harvesting or any other expenses, for any other reasons.

Gearmore in no way warrants engines, tires, or other trade accessories, since these items are warranted separately by these respective manufacturers.

Gearmore reserves the right to make improvements in design or changes in specification at any time, without incurring any obligations to owners or units previously sold.

GEARMORE, INC.
13477 Benson Ave.
Chino, CA 91710

Always refer to and heed machine operating warning decals on machine.

The serial number of this product is stored in our computer database, thus submitting a warranty registration card is not required.