

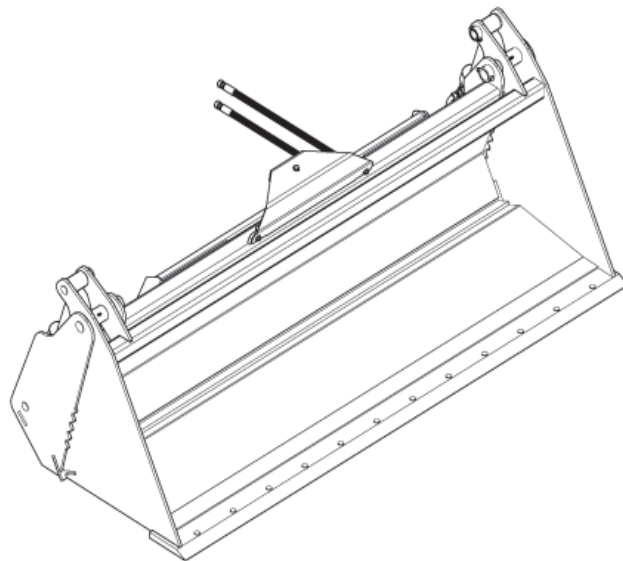

FOUR-IN-ONE BUCKETS



**Assembly, Parts
& Operator's Manual
For Models
MD4-66, MD4-72 & MD4-78**

March 2005

TABLE OF CONTENTS

SECTION	DESCRIPTION	PAGE
1	Introduction	1
1.1	Serial Number Location	1
2	Safety	2
2.1	General Safety	3
2.2	Equipment Safety Guidelines	4
2.3	Safety Training	5
2.4	Safety Signs	5
2.5	Preparation	6
2.6	Hydraulic Safety	6
2.7	Operating Safety	7
2.8	Transport Safety	8
2.9	Storage Safety	8
2.10	Maintenance Safety	8
3	Safety Sign Locations	9
4	Operation	10
4.1	To the New Operator or Owner	10
4.2	Machine Components	10
4.3	Assembly	11
4.4	Pre-Operation Checklist	11
4.5	Field Operation	12
4.6	Transporting	13
4.7	Storage	13
5	Service and Maintenance	14
5.1	Service	14
5.1.1	Fluids and Lubricants	14
5.1.2	Greasing	14
5.1.3	Servicing Intervals	14
5.2	Maintenance	15
5.3	Ordering Parts	15
6	Specifications	16
6.1	Mechanical	16
6.2	Bolt Torque	17
7	Parts Breakdown	18
7.1	Bucket	18
7.2	Hydraulics With 2" Cylinders	19-20
7.4	Cylinder Assembly with 2" Bore	21
7.6	Parts Acronyms	22
8	Limited Warranty	23

1 INTRODUCTION

Congratulations on your choice of a Four-In-One Bucket. This equipment has been designed and manufactured to meet the needs of a discriminating buyer for efficient lifting, back-filling, loading, and scraping operations.

Safe, efficient and trouble free operation of your Four-In-One Bucket requires that you and anyone else who will be operating or maintaining the machine, read and understand the Safety, Operation, and Maintenance information contained within the Operator's Manual.

This manual covers the Four-In-One Buckets. Use the Table of Contents as a guide to locate required information.

Keep this manual handy for frequent reference and to pass on to new operators or owners. Call your dealer if you need assistance, information or additional copies of the manuals.

OPERATOR ORIENTATION - The directions left, right, front and rear, as mentioned throughout this manual, are as seen from the driver's seat and facing in the direction of travel.

NOTE: Gearmore reserves the right to discontinue models at any time, change specifications, and improve design without notice and without incurring obligation on goods previously purchased and to discontinue supplying any part listed, when the demand does not warrant production.

1.1 SERIAL NUMBER LOCATION

It is very important that the correct serial number is provided when ordering parts.

The serial number plate is located on the back left corner of the bucket weldment as indicated below.

Please mark the model and serial number of your attachment in the space provided below in case the plate on your attachment gets lost or damaged.

Model No: _____

Serial No: _____

Date of Purchase: _____

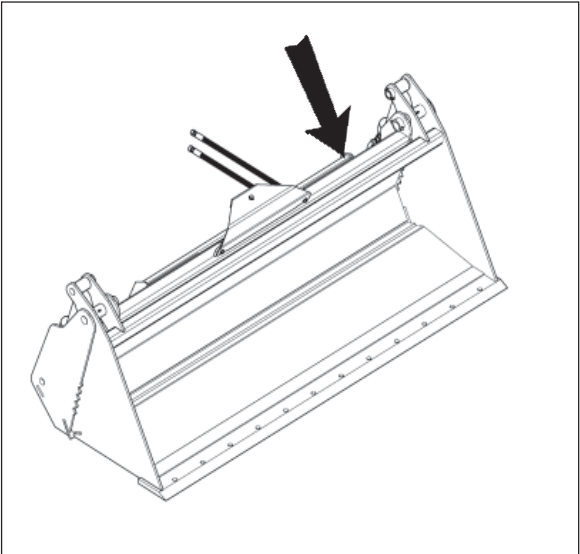

2 SAFETY

SAFETY ALERT SYMBOL

This Safety Alert symbol means **ATTENTION! BECOME ALERT! YOUR SAFETY IS INVOLVED!**



The Safety Alert symbol identifies important safety messages on the Gearmore Four-In-One Bucket and in the manual. When you see this symbol, be alert to the possibility of personal injury or death. Follow the instructions in the safety message.

Why is SAFETY important to you?

3 Big Reasons

Accidents Disable and Kill
Accidents Cost
Accidents Can Be Avoided

SIGNAL WORDS:

Note the use of the signal words **DANGER**, **WARNING** and **CAUTION** with the safety messages. The appropriate signal word for each message has been selected using the following guide-lines:

SI NO LEE INGLES, PIDA AYUDA A AIGUIEN QUE SI LO LEA PARA QUE LE TRADUZCA LAS MIDIDAS DE SEGURIDAD.

DANGER - Indicates an imminently hazardous situation that, if not avoided, will result in death or serious injury. This signal word is to be limited to the most extreme situations typically for machine components which, for functional purposes, cannot be guarded.

WARNING - Indicates a potentially hazardous situation that, if not avoided, could result in death or serious injury, and includes hazards that are exposed when guards are removed. It may also be used to alert against unsafe practices.

CAUTION - Indicates a potentially hazardous situation that, if not avoided, may result in minor or moderate injury. It may also be used to alert against unsafe practices.

If you have any questions not answered in this manual or require additional copies or the manual is damaged, please contact your dealer.

SAFETY

YOU are responsible for the **SAFE** operation and maintenance of your Four-In-One Bucket. **YOU** must ensure that you and anyone else who is going to operate, maintain or work around the Four-In-One Bucket be familiar with the operating and maintenance procedures and related **SAFETY** information contained in this manual. This manual will take you step-by-step through your working day and alerts you to all good safety practices that should be adhered to while operating the Four-In-One Bucket.

Remember, **YOU** are the key to safety. Good safety practices not only protect you but also the people around you. Make these practices a working part of your safety program. Be certain that **EVERYONE** operating this equipment is familiar with the recommended operating and maintenance procedures and follows all the safety precautions. Most accidents can be prevented. Do not risk injury or death by ignoring good safety practices.

- Implement owners must give operating instructions to operators or employees before allowing them to operate the machine, and at least annually thereafter per OSHA (Occupational Safety and Health Administration) regulation 1928.57.
- The most important safety feature on this equipment is a **SAFE** operator. It is the operator's responsibility to read and understand **ALL** Safety and Operating instructions in the manual and to follow these. Most accidents can be avoided.
- A person who has not read and understood all operating and safety instructions is not qualified to operate the machine. An untrained operator exposes himself and bystanders to possible serious injury or death.
- Do not modify the equipment in any way. Unauthorized modification may impair the function and/or safety and could affect the life of the equipment.
- **Think SAFETY! Work SAFELY!**

2.1 GENERAL SAFETY

1. Read and understand the Operator's Manual and all safety signs before operating, maintaining, adjusting or unplugging the Four-In-One Bucket



2. Have a first-aid kit available for use should the need arise and know how to use it.



3. Have a fire extinguisher available for use should the need arise and know how to use it.

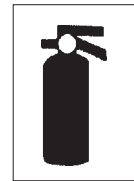

4. Wear appropriate protective gear. This list includes but is not limited to:

- A hard hat
- Protective shoes with slip resistant soles
- Protective goggles, glasses or face shield
- Heavy gloves
- Protective clothing



5. Do not allow riders.
6. Wear suitable ear protection for prolonged exposure to excessive noise.



7. Place all controls in neutral, stop tractor/skid steer engine, set park brake, remove ignition key and wait for all moving parts to stop before servicing, adjusting, repairing or unplugging.
8. Clear the area of people, especially small children, before starting.
9. Review safety related items annually with all personnel who will be operating or maintaining the Four-In-One Bucket.

2.2 EQUIPMENT SAFETY GUIDELINES

1. Safety of the operator and bystanders is one of the main concerns in designing and developing a machine. However, every year many accidents occur which could have been avoided by a few seconds of thought and a more careful approach to handling equipment. You, the operator, can avoid many accidents by observing the following precautions in this section. To avoid personal injury or death, study the following precautions and insist those working with you, or for you, follow them.
2. **DO NOT EXCEED THE LOADER'S SAE OPERATING LOAD.** See the operator's manual of the loader for load specifications. Remember to include the weight of the Four-In-One Bucket in the total weight to be lifted by the loader.

WEIGHT CHART	
Four-In-One Bucket	
MODEL	WEIGHT
MP4-66	570#
MP4-72	608#
MP4-78	645#

3. Replace any safety sign or instruction sign that is not readable or is missing. Location of such safety signs is indicated in this manual.
4. Never use alcoholic beverages or drugs which can hinder alertness or coordination while operating this equipment. Consult your doctor about operating this machine while taking prescription medications.
5. Use a tractor equipped with a Roll Over Protective Structure (ROPS) and a seat belt.

6. **Under no circumstances should young children be allowed to work with this equipment. Do not allow persons to operate or assemble this unit until they have read this manual and have developed a thorough understanding of the safety precautions and of how it works.** Review the safety instructions with all users annually.
7. This equipment is dangerous to children and persons unfamiliar with its operation. The operator should be a responsible, properly trained and physically able person familiar with farm machinery and trained in this equipment's operations. If the elderly are assisting with work, their physical limitations need to be recognized and accommodated.
8. Never exceed the limits of a piece of machinery. If its ability to do a job, or to do so safely, is in question - **DON'T TRY IT.**
9. **Do not** modify the equipment in any way. Unauthorized modification may result in serious injury or death and may impair the function and life of the equipment.
10. In addition to the design and configuration of this implement, including Safety Signs and Safety Equipment, hazard control and accident prevention are dependent upon the awareness, concern, prudence, and proper training of personnel involved in the operation, transport, maintenance, and storage of the machine. Refer also to Safety Messages and operation instruction in each of the appropriate sections of the Tractor/Skid Steer and Machine Manuals. Pay close attention to the Safety Signs affixed to the Tractor/Skid Steer and the machine.

2.3 SAFETY TRAINING

1. Safety is a primary concern in the design and manufacture of our products. Unfortunately, our efforts to provide safe equipment can be wiped out by a single careless act of an operator or bystander.
2. In addition to the design and configuration of equipment, hazard control and accident prevention are dependent upon the awareness, concern, prudence and proper training of personnel involved in the operation, transport, maintenance and storage of this equipment.
3. It has been said, "The best safety feature is an informed, careful operator." We ask you to be that kind of an operator. It is the operator's responsibility to read and understand ALL Safety and Operating instructions in the manual and to follow these. Accidents can be avoided.
4. **Working with unfamiliar equipment can lead to careless injuries. Read this manual, and the manual for your tractor/skid steer, before assembly or operating, to acquaint yourself with the machines. If this machine is used by any person other than yourself, or is loaned or rented, it is the machine owner's responsibility to make certain that the operator, prior to operating:**
 - a. **Reads and understands the operator's manuals.**
 - b. **Is instructed in safe and proper use.**
5. Know your controls and how to stop tractor/skid steer engine, and machine quickly in an emergency. Read this manual and the one provided with your tractor.
6. Train all new personnel and review instructions frequently with existing workers. Be certain only a properly trained and physically able person will operate the machinery. A person who has not read and understood all operating and safety instructions is not qualified to operate the machine. An untrained operator exposes himself and bystanders to possible serious injury or death. If the elderly are assisting with farm work, their physical limitations need to be recognized and accommodated.

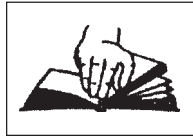

2.4 SAFETY SIGNS

1. Keep safety signs clean and legible at all times.
2. Replace safety signs that are missing or have become illegible.
3. Replaced parts that displayed a safety sign should also display the current sign.
4. Safety signs are available from your authorized Distributor or Dealer Parts Department or the factory.

How to Install Safety Signs:

- Be sure that the installation area is clean and dry.
- Be sure temperature is above 50°F (10°C).
- Determine exact position before you remove the backing paper. (See Section 3).
- Remove the smallest portion of the split backing paper.
- Align the sign over the specified area and carefully press the small portion with the exposed sticky backing in place.
- Slowly peel back the remaining paper and carefully smooth the remaining portion of the sign in place.
- Small air pockets can be pierced with a pin and smoothed out using the piece of sign backing paper.

2.5 PREPARATION

1. Never operate the tractor/skid steer and machine until you have read and completely understand this manual, the Tractor/Skid Steer Operator's Manual, and each of the Safety Messages found on the safety signs on the tractor/skid steer and machine.

2. Personal protection equipment including hard hat, safety glasses, safety shoes, and gloves are recommended



during assembly, installation, operation, adjustment, maintaining, repairing, removal, or moving the implement. Do not allow long hair, loose fitting clothing or jewelry to be around equipment.

3. **PROLONGED EXPOSURE TO LOUD NOISE MAY CAUSE PERMANENT HEARING LOSS!**

Tractors/Skid Steers with or without equipment attached can often be noisy enough to cause permanent, partial hearing loss. We recommend that you wear hearing protection on a full-time basis if the noise in the Operator's position exceeds 80db. Noise over 85db on a long-term basis can cause severe hearing loss. Noise over 90db adjacent to the Operator over a long-term basis may cause permanent, total hearing loss. **NOTE:** Hearing loss from loud noise (from tractors, chain saws, radios, and other such sources close to the ear) is cumulative over a lifetime without hope of natural recovery.

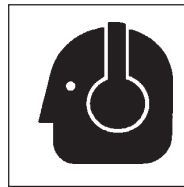

4. Operate the machine only with a tractor equipped with an approved Roll-Over-Protective Structure (ROPS). Always wear your seat belt. Serious injury or even death could result from falling off the tractor --- particularly during a turnover when the operator could be pinned under the ROPS or the tractor.



5. Operate only in daylight or good artificial light.
6. Be sure machine is properly mounted, adjusted and in good operating condition.
7. Ensure that all safety shielding and safety signs are properly installed and in good condition.

2.6 HYDRAULIC SAFETY

1. Make sure that all the components in the hydraulic system are kept in good condition and are clean.
2. Replace any worn, cut, abraded, flattened or crimped hoses and metal lines.
3. Before investigating or repairing leaks, shut off the tractor/skid steer engine and move the hydraulic control valve to open and close positions several times, to relieve pressure in the hydraulic lines.
4. Do not attempt any makeshift repairs to the hydraulic lines, fittings or hoses by using tapes, clamps or cements. The hydraulic system operates under extremely high-pressure. Such repairs will fail suddenly and create a hazardous and unsafe condition.
5. Wear proper hand and eye protection when searching for a high-pressure hydraulic leak. Use a piece of wood or cardboard as a backstop instead of hands to isolate and identify a leak.

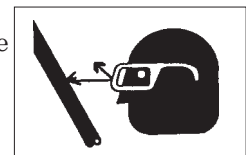

6. If injured by a concentrated high-pressure stream of hydraulic fluid, seek medical attention immediately. Serious infection or toxic reaction can develop from hydraulic fluid piercing the skin surface.
7. Before applying pressure to the system, make sure all components are tight and that lines, hoses and couplings are not damaged.

- **Think SAFETY! Work SAFELY!**

2.7 OPERATING SAFETY

1. Please remember it is important that you read and heed the safety signs on the Four-In-One Bucket. Clean or replace all safety signs if they cannot be clearly read and understood. They are there for your safety, as well as the safety of others. The safe use of this machine is strictly up to you, the operator.
2. All things with moving parts are potentially hazardous. There is no substitute for a cautious, safe-minded operator who recognizes potential hazards and follows reasonable safety practices.
3. Safety is our first concern at Gearmore. Safety must also be first in the mind of the operator of the Four-In-One Bucket. Proper maintenance is necessary to complete the safety cycle.
4. Personal protection equipment including hard hat, safety glasses, hearing protection, safety shoes, and tight gloves are recommended during assembly, installation, operation, adjustment, maintaining, repairing, removal, or moving. Do not allow long hair, loose fitting clothing, or jewelry to be around moving parts.
5. Always use two people to handle heavy, unwieldy components during assembly, installation, removal or moving.
6. Never place any part of your body, fingers, hands, feet, etc. where it would be in danger if movement should occur during assembly, installation, operation, maintaining, repairing, removal or moving. Keep others away.
7. Never use alcoholic beverages or drugs which can hinder alertness or coordination while operating this equipment. Consult your doctor about operating this machine while taking prescription medications.
8. Do not allow riders on the machine or tractor/skid steer at any time. There is no safe place for any riders.
9. Before you operate the machine, check over all pins, bolts, connections and hydraulic components to be sure all are securely in place and tight. Tighten or replace any leaking, damaged or worn parts immediately.
10. Do not allow anyone who is not familiar with the safety rules and operation instructions to use this machine.
11. Never allow children to operate or be around this machine.
12. Do not operate on slopes or hillsides. Sloping terrain can cause machine to roll or slip.

2.8 TRANSPORT SAFETY

1. Comply with state and local laws governing highway safety and movement of machinery on public roads.
2. The use of flashing amber lights is acceptable in most localities. However, some localities prohibit their use. Local laws should be checked for all highway lighting and marking requirements.
3. At all times, when driving the tractor and equipment on the road or highway under 20 mph (32 kph) use flashing amber warning lights and a slow moving vehicle (SMV) identification emblem. Do not exceed 20 mph (32 kph). Reduce speed on rough roads and surfaces.
4. Plan your route to avoid heavy traffic.
5. Always install transport locks, pins or brackets before transporting.
6. Do not drink and drive.
7. Be a safe and courteous driver. Always yield to oncoming traffic in all situations, including narrow bridges, intersections, etc. Watch for traffic when operating near or crossing roadways.
8. Turn into curves or go up or down hills only at a low speed and at a gradual steering angle. Make certain that at least 20% of the tractor's weight is on the front wheels to maintain safe steering. Slow down on rough or uneven surfaces.
9. A heavy load can cause instability of the tractor. Use extreme care during travel. Slow down on turns and watch out for bumps.
10. Never allow riders on either tractor/skid steer or bucket.

2.9 STORAGE SAFETY

1. Store the unit in an area away from human activity.
2. Do not permit children to play on or around the stored machine.
3. Store the unit in a dry, level area. Support the bucket with planks if required.

2.10 MAINTENANCE SAFETY

1. Good maintenance is your responsibility. Poor maintenance is an invitation to trouble.
2. Follow good shop practices.
 - Keep service area clean and dry.
 - Be sure electrical outlets and tools are properly grounded.
 - Use adequate light for the job at hand.
3. Make sure there is plenty of ventilation. Never operate the engine of the tractor/skid steer in a closed building. The exhaust fumes may cause asphyxiation.
4. Before working on this machine, shut off the engine, set the brakes, and remove the ignition keys.
6. Never work under equipment unless it is blocked securely.
7. Use personal protection devices such as eye, hand and hearing protectors, when performing any service or maintenance work.
8. Where replacement parts are necessary for periodic maintenance and servicing, genuine factory replacement parts must be used to restore your equipment to original specifications. The manufacturer will not be responsible for injuries or damages caused by use of unapproved parts and/or accessories.
9. A fire extinguisher and first aid kit should be kept readily accessible while performing maintenance on this equipment.

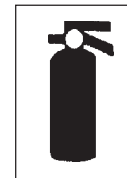

10. Periodically tighten all bolts, nuts and screws and check that all cotter pins are properly installed to ensure unit is in a safe condition.
11. Remember that well-maintained equipment is safer, will perform better, and provide longer service life!

3 SAFETY SIGN LOCATIONS

The types of safety signs and locations on the equipment are shown in the illustration below. Good safety requires that you familiarize yourself with the various safety signs, the type of warning and the area, or particular function related to that area, that requires your SAFETY AWARENESS.



Part No. 000-186-023
Location: Top of bucket



Part No. 000-186-035
Location: Back of Weldment

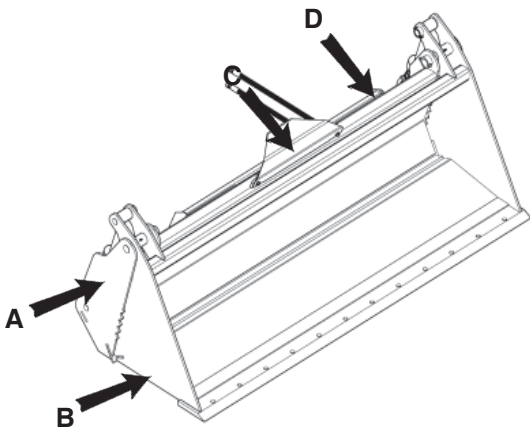

Part No. 000-186-041
Location: Side of bucket back

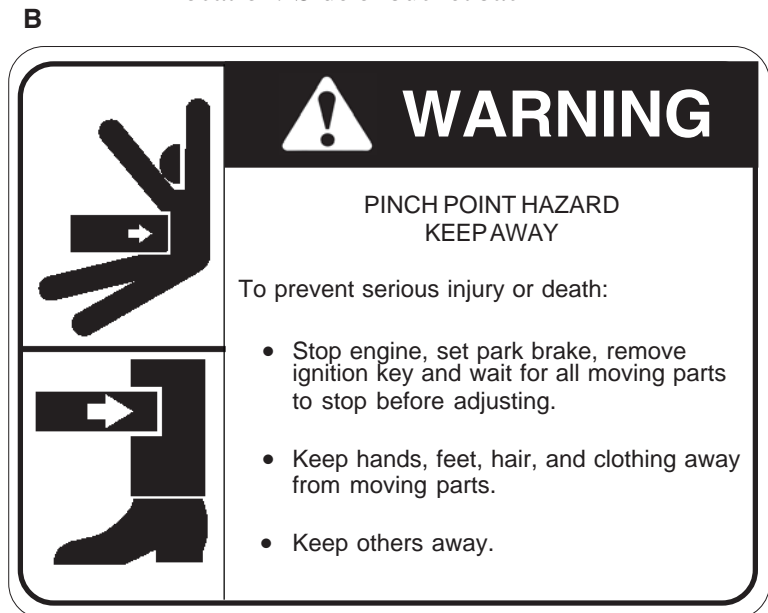

Part No. 000-186-057
Location: Side of clam

REMEMBER - If safety signs have been damaged, removed, become illegible or parts replaced without signs, new signs must be applied. New signs are available from your authorized dealer.

4 OPERATION



OPERATING SAFETY

1. Read and understand the Operator's Manual and all safety signs before operating, servicing, adjusting, repairing or unplugging.
2. Do not allow riders.
3. Keep hands, feet, hair and clothing away from moving parts.
4. Place all controls in neutral, stop tractor/skid steer engine, set park brake, remove ignition key and wait for all moving parts to stop before servicing, adjusting, repairing or unplugging.
5. Place all tractor/skid steer and machine controls in neutral before starting.
6. Always wear the appropriate personal safety equipment when operating equipment including but not limited to hard hat, safety shoes, face shield and heavy gloves.
7. Clear the area of bystanders, especially small children, before starting.
8. Do not operate on slopes or sidehills.
9. Keep all mechanical and hydraulic components in good condition. Do not operate with leaks or damaged components.
10. **DO NOT EXCEED** the loader's SAE operating load. See the operator's manual of the loader for load specifications. Remember to include the weight of the Four-In-One Bucket in the total weight to be lifted by the loader.
11. Review safety instructions with all operators annually.

4.1 TO THE NEW OPERATOR OR OWNER

The Four-In-One Buckets were especially designed for tractors under 40 horsepower. The buckets are made of high strength steel and are light enough for the loader to lift a full bucket load. The buckets are designed to pin directly to your loader arms. A quick attach system is also available to make switching buckets and other attachments easier. Four-In-One means versatility. All with one bucket, you can load, doze, scrape and grapple. Be familiar with the machine before starting.

It is the responsibility of the owner or operator to read this manual and to train all other operators before they start working with the machine. Follow all safety instructions exactly. Safety is everyone's business. By following recommended procedures, a safe working environment is provided for the operator, bystanders and the area around the worksite. Untrained operators are not qualified to operate the machine.

Many features incorporated into this machine are the result of suggestions made by customers like you. Read this manual carefully to learn how to operate the machine safely and how to set it to provide maximum field efficiency. By following the operating instructions in conjunction with a good maintenance program, your Four-In-One Bucket will provide many years of trouble-free service.

4.2 MACHINE COMPONENTS

The Four-In-One Bucket consists of a bucket weldment, clam weldment, cutting edge, and cylinder assembly. Hydraulic power from the tractor/skid steer is routed through a double acting valve to control the cylinder position. The bucket can be used for loading, scraping, grappling, dozing, etc.

4.3 ASSEMBLY

The machine is shipped from the factory in a partially disassembled form that allows for easy and convenient shipping. Refer to the drawing and parts list should it become necessary to disassemble the unit for repair or replacement of parts.

Please refer to loader operator's manual for attachment installation instructions.

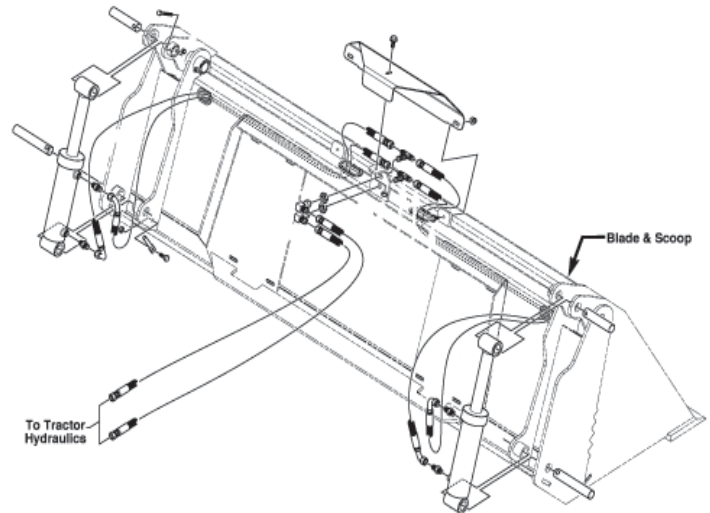

4.4 PRE-OPERATION CHECKLIST

Although there are no operational restrictions on the Four-In-One Bucket when used for the first time, it is recommended that the following mechanical items be checked:

A. After Operating For 1 and 5 Hours:

1. Check all nuts, bolts and other fasteners. Tighten to their specified torque level.
2. Lubricate all grease fittings every ten (10) hours of operation.
3. Check hydraulic system for leaks. Tighten all leaking fittings and replace any leaking components.
4. Then go to the service schedule as defined in the Maintenance Section.

Remember that well-maintained equipment is safer, will perform better, and provide longer service life!

Efficient and safe operation of the Four-In-One Bucket requires that each operator reads and understands the operating procedures and all related safety precautions outlined in this section. A pre-operation checklist is provided for the operator. It is important for both the personal safety and maintaining the good mechanical condition of the Four-In-One Bucket that this checklist is followed.

Before operating the machine and each time thereafter, the following areas should be checked off:

1. Use only a small Agricultural tractor/skid steer of less than 40 horsepower on the machine.
2. Check that the machine is properly attached to the tractor/skid steer. Refer to loader operator's manual for attachment installation instructions.
3. Check for hydraulic leaks, tighten fittings or replace components to stop leaks.
4. Check all pivot pins and fasteners; replace them as needed.
5. Lubricate all grease fittings every ten (10) hours of operation.

4.5 FIELD OPERATION



OPERATING SAFETY

1. Read and understand the Operator's Manual and all safety signs before operating, servicing, adjusting, repairing or unplugging.
2. Do not allow riders.
3. Keep hands, feet, hair and clothing away from moving parts.
4. Place all controls in neutral, stop tractor/skid steer engine, set park brake, remove ignition key and wait for all moving parts to stop before servicing, adjusting, repairing or unplugging.
5. Place all tractor/skid steer and machine controls in neutral before starting.
6. Always wear the appropriate personal safety equipment when operating equipment including but not limited to hard hat, safety shoes, face shield and heavy gloves.
7. Clear the area of bystanders, especially small children, before starting.
8. Do not operate on slopes or sidehills.
9. Keep all mechanical and hydraulic components in good condition. Do not operate with leaks or damaged components.
10. Before investigating or repairing hydraulic leaks, shut off the tractor/skid steer engine and move the hydraulic control valve to open and close positions several times, to relieve pressure in the hydraulic lines.
11. DO NOT EXCEED the loader's SAE operating load.
12. Review safety instructions with all operators annually.

Each operator should review this section of the manual at the start of the season and as often as required to be familiar with the machine. When using, follow this procedure:

1. Review and follow the Pre-Operation Checklist.
2. Attach the tractor/skid steer to the machine following the installation instructions in the loader operator's manual.
3. **Attach the Hydraulics:**
 - a. Use a clean cloth or paper towel to clean the tips on the end of the hoses and the area around the couplers on the tractor/skid steer.

IMPORTANT

Do not use on a tractor of more than 40 horsepower.

 **WARNING**

	
--	---

Use extreme care when working around a high-pressure hydraulic system. Make sure all connections are tight and all components are in good repair. Wear hand and eye protection when searching for suspected leaks.

4.6 TRANSPORTING



TRANSPORT SAFETY

1. Make sure you are in compliance with all local regulations regarding transporting equipment on public roads and highways.
2. Make sure the SMV (Slow Moving Vehicle) emblem and all the lights and reflectors that are required by the local highway and transport authorities are in place, are clean and can be seen clearly by all overtaking and oncoming traffic.
3. Do not allow anyone to ride on the bucket or tractor/skid steer during transport.
4. Do not exceed 20 mph (32 kph). Reduce speed on rough roads and surfaces.
6. Always use hazard flashers on the tractor/skid steer when transporting unless prohibited by law.

When transporting the machine, review and follow these instructions:

1. Be sure all bystanders are clear of the machine.
2. Be sure that the machine is securely attached to the tractor/skid steer and all retainer pins are installed.
3. Clean the SMV emblem, lights and reflectors and be sure they are working.
4. Be sure you are in compliance with all applicable lighting and marking regulations when transporting. Check with your local authorities.
5. Be sure your machine can clearly be seen by overtaking and oncoming traffic.
6. Keep to the right and yield the right-of-way to allow faster traffic to pass. Drive on the road shoulder if permitted by law.
7. Do not allow riders.
8. Always use hazard flashers on the tractor/skid steer when transporting unless prohibited by law.

4.7 STORAGE



STORAGE SAFETY

1. Store the unit in an area away from human activity.
2. Do not permit children to play on or around the stored machine.
3. Store the unit in a dry, level area. Support the frame with planks if required.

After the season's use, the machine should be thoroughly inspected and prepared for storage. Repair or replace any worn or damaged components to prevent any unnecessary down time at the start of next season. To insure a long, trouble free life, this procedure should be followed when preparing the unit for storage:

1. Clear the area of bystanders, especially small children.
2. Thoroughly wash the machine using a pressure washer to remove all dirt, mud, debris and residue.
3. Inspect the bucket and hydraulic fittings for damage. Repair or replace damaged parts.
4. Touch up all paint nicks and scratches to prevent rusting.
5. Move to storage area.
6. Select an area that is dry, level and free of debris.
7. Unhook from tractor/skid steer.
8. If the bucket cannot be placed inside, cover with a waterproof tarpaulin and tie securely in place.
9. Store the bucket in an area away from human activity.
10. Do not allow children to play on or around the stored machine.

5 SERVICE AND MAINTENANCE



MAINTENANCE SAFETY

1. Follow ALL the operating, maintenance and safety information in the manual.
2. Support the machine with blocks or safety stands when working beneath it.
3. Follow good shop practices.
 - Keep service area clean and dry.
 - Be sure electrical outlets and tools are properly grounded.
 - Use adequate light for the job at hand.
3. Make sure there is plenty of ventilation. Never operate the engine of the tractor/skid steer in a closed building. The exhaust fumes may cause asphyxiation.
4. Use only tools, jacks and hoists of sufficient capacity for the job.
5. Clear the area of bystanders, especially small children, when carrying out any maintenance and repairs or making any adjustments.
6. Never perform maintenance or service work such as lubricating, inspecting, clearing debris, etc., while the tractor/skid steer engine is running. Shut off the tractor/skid steer engine and remove the key before performing these functions

Good maintenance is your responsibility. Poor maintenance is an invitation to trouble.

DO NOT operate your Four-In-One Bucket in poor mechanical condition or when in need of repair.

1. Check all hydraulic hoses frequently for leaks or damage. Replace defective hoses before operating the bucket.
2. Check all pivot pins and fasteners; replace them as needed.
3. Remember that well-maintained equipment is safer, will perform better, and provide longer service life!

5.1 SERVICE

5.1.1 LUBRICANTS

1. **Grease:**
Use an SAE multi-purpose high temperature grease with extreme pressure (EP) performance. Also acceptable is an SAE multipurpose lithium base grease.
2. **Storing Lubricants:**
Your machine can operate at top efficiency only if clean lubricants are used. Use clean containers to handle all lubricants. Store them in an area protected from dust, moisture and other contaminants.

5.1.2 GREASING

Use a Maintenance Checklist to keep a record of all scheduled maintenance.

1. Use a hand-held grease gun for all greasing.
2. Wipe grease fitting with a clean cloth before greasing to avoid injecting dirt and grit.
3. Replace and repair broken fittings immediately.
4. If fittings will not take grease, remove and clean thoroughly. Also clean lubricant passage. Replace fitting if necessary.

5.1.3 SERVICING INTERVALS

The period recommended is based on normal operating conditions. Severe or unusual conditions may require more frequent servicing.

Daily or 10 Hours

1. Lubricate all grease fittings every ten (10) hours of operation.

Annually

1. Clean machine.

5.2 MAINTENANCE

By following a good maintenance program, your equipment will last for many years. With normal use the bucket will not require any regular maintenance other than the inspection of hoses and fittings and lubricating all grease fittings every ten (10) hours of operation. However it is good practice to check all pivot pins and fasteners often; replacing them as needed.

REMINDER: Never perform maintenance or service work such as lubricating, inspecting, clearing debris, etc., while the tractor/skid steer engine is running. Shut off the tractor/skid steer engine and remove the key before performing these functions.

5.3 ORDERING PARTS

When replacement parts and service are required for your attachment, Gearmore recommends returning to the dealer from which the attachment was purchased. By going to the dealer, you are dealing with people that understand and know your attachment. Our dealers have the experience servicing these machines and stock the most common parts required to keep your attachment in top working condition.

Parts lists contained in this book have been prepared to help you when ordering spare and/or replacement parts. Your order will be filled promptly and accurately when the following information is provided:

1. Model and serial number of the unit. (This specifically identifies the equipment you have and permits us to verify the part numbers in your order.)
2. The parts list page number and catalog number. Include catalog revision number, if applicable.
3. The **REF** number for each part. **REF** numbers on the parts list page correspond with the numbers shown on the illustration.
4. **Part Number** as it appears in the parts list. In most cases this will be a nine-digit number; for example: 200-147-000.

5. The **Description** for the part as it appears on the parts list page.

When a complete assembly is needed, use the assembly number given in the parts list. If no assembly number is given, order by main assembly title and list only the item numbers you want. For example: "Cylinder Assembly 2" bore x 6" Stroke per 000-166-169, Items 2 through 15, inclusive".

The part ordered may have a new part number, or the part may have been replaced by a newer design with a different part number. In these cases your acknowledgement, shipping papers and invoices will be written listing the current part number first; the old part number you referred to will follow the part description.

Our purpose in doing this is to tell you that the parts are fully interchangeable. This will avoid any unnecessary correspondence or delay in processing your order. We suggest that you add any new number to your parts lists for future use.

All replacement parts must meet manufacturer's specifications. The manufacturer will not be responsible for injuries or damages caused by use of unapproved parts and/or accessories.

6 SPECIFICATIONS

6.1 MECHANICAL

Loader Lift Capacity:	2700#
2-Hydraulic Cylinders:	2" x 6"
Clamping Force:	3000#
Torque Tube Crossbar:	Yes
Overall Bucket Depth:	30"
Overall Bucket Height:	27"
Clam Depth:	20 1/2"
Dozer Blade Depth:	4"
Maximum Clam Opening:	30 1/2"

SPECIFICATIONS ARE SUBJECT TO CHANGE WITHOUT NOTICE

MODEL NUMBER	DESCRIPTION	WORKING WIDTH	CAP. CU. FT.	CUTTING EDGE	WEIGHT
MD4-66	Heavy Duty Bucket	66"	12	3/4" x 6"	570#
MD4-72	Heavy Duty Bucket	72"	13.2	3/4" x 6"	608#
MD4-78	Heavy Duty Bucket	78"	14	3/4" x 6"	645#



CAUTION: DO NOT EXCEED THE LOADER'S SAE OPERATING LOAD. See the operator's manual of the loader for load specifications. Remember to include the weight of the Four-In-One Bucket in the total weight to be lifted by the loader.

6.2 BOLT TORQUE

CHECKING BOLT TORQUE

The tables shown below give correct torque values for various bolts and capscrews. Tighten all bolts to the torques specified in chart unless otherwise noted. Check tightness of bolts periodically, using bolt torque chart as a guide. Replace hardware with the same strength bolt.

ENGLISH TORQUE SPECIFICATIONS

Bolt Diameter "A"	Bolt Torque *					
	SAE 2		SAE 5		SAE 8	
	N.m	(lb-ft)	N.m	(lb-ft)	N.m	(lb-ft)
1/4"	8	(6)	12	(9)	17	(12)
5/16"	13	(10)	25	(19)	36	(27)
3/8"	27	(20)	45	(33)	63	(45)
7/16"	41	(30)	72	(53)	100	(75)
1/2"	61	(45)	110	(80)	155	(115)
9/16"	95	(70)	155	(115)	220	(165)
5/8"	128	(95)	215	(160)	305	(220)
3/4"	225	(165)	390	(290)	540	(400)
7/8"	230	(170)	570	(420)	880	(650)
1"	345	(225)	850	(630)	1320	(970)

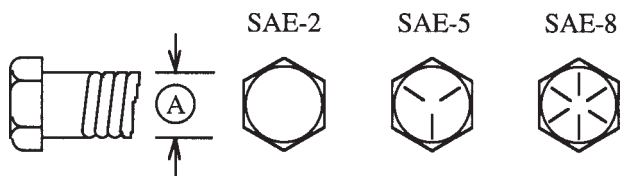

Torque figures indicated above are valid for non-greased or non-oiled threads and heads unless otherwise specified. Therefore, do not grease or oil bolts or capscrews unless otherwise specified in this manual. When using locking elements, increase torque values by 5%.

* Torque value for bolts and capscrews are identified by their head markings.

7 PARTS BREAKDOWN

7.1 BUCKET

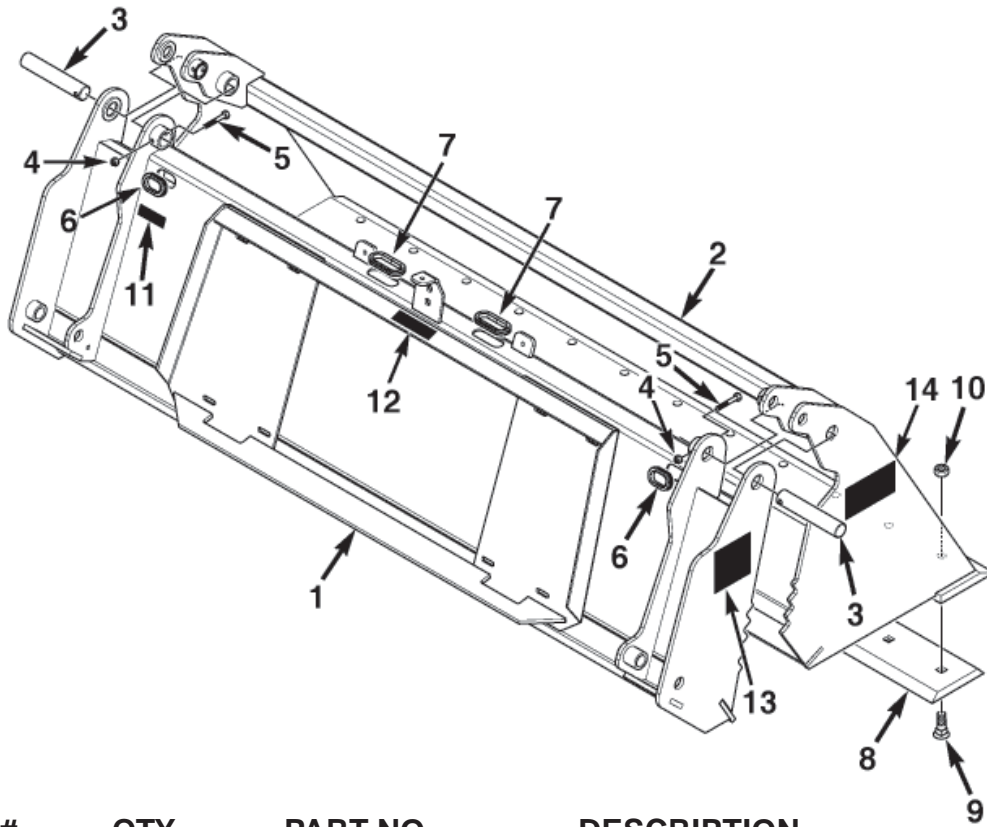

<u>REF #</u>	<u>QTY.</u>	<u>PART NO.</u>	<u>DESCRIPTION</u>
1	1	311-013-100	Bucket Weldment, 66"
1	1	311-014-100	Bucket Weldment, 72"
1	1	311-015-100	Bucket Weldment, 78"
2	1	311-013-200	Scoop Weldment, 66"
2	1	311-014-200	Scoop Weldment, 72"
2	1	311-015-200	Scoop Weldment, 78"
3	2	000-161-095	Pivot Pin, 1 ¹ / ₄ " Dia. x 6 ³ / ₄ " Long
4	2	O/L	Bolt, Hex Head, ⁵ / ₁₆ " - 18UNC x 2 ¹ / ₄ " Long
5	2	O/L	Hex Nut, Nylon Lock, ⁵ / ₁₆ " - 18UNC
6	2	001-001-062	Grommet, 2 ¹ / ₈ " OD x 1 ¹ / ₂ " ID x 3-16" Groove
7	2	001-001-061	Grommet, 2 ³ / ₄ " OD x 2" ID x 3-16" Groove
8	1	000-190-084	Cutting Edge, DBF, 67 ⁷ / ₈ ", Optional
8	1	000-190-085	Cutting Edge, DBF, 73 ⁷ / ₈ ", Optional
8	1	000-190-086	Cutting Edge, DBF, 79 ⁷ / ₈ ", Optional
9	As Req'd	000-150-262	Plow Bolt, ⁵ / ₈ " - 11UNC x 2" Long, Grade 8
10	As Req'd	000-158-139	Hex Nut, ⁵ / ₈ " - 11UNC, Grade 8
11	1	000-186-035	Plate, Model/Serial, Adhesive Back
12	1	000-186-023	Decal, Caution, (Do Not Exceed)
13	2	000-186-041	Decal, Warning, (High Pressure Fluid Hazard)
14	2	000-186-057	Decal, Warning, (Pinch Point)

7.2 HYDRAULICS WITH 2" CYLINDERS

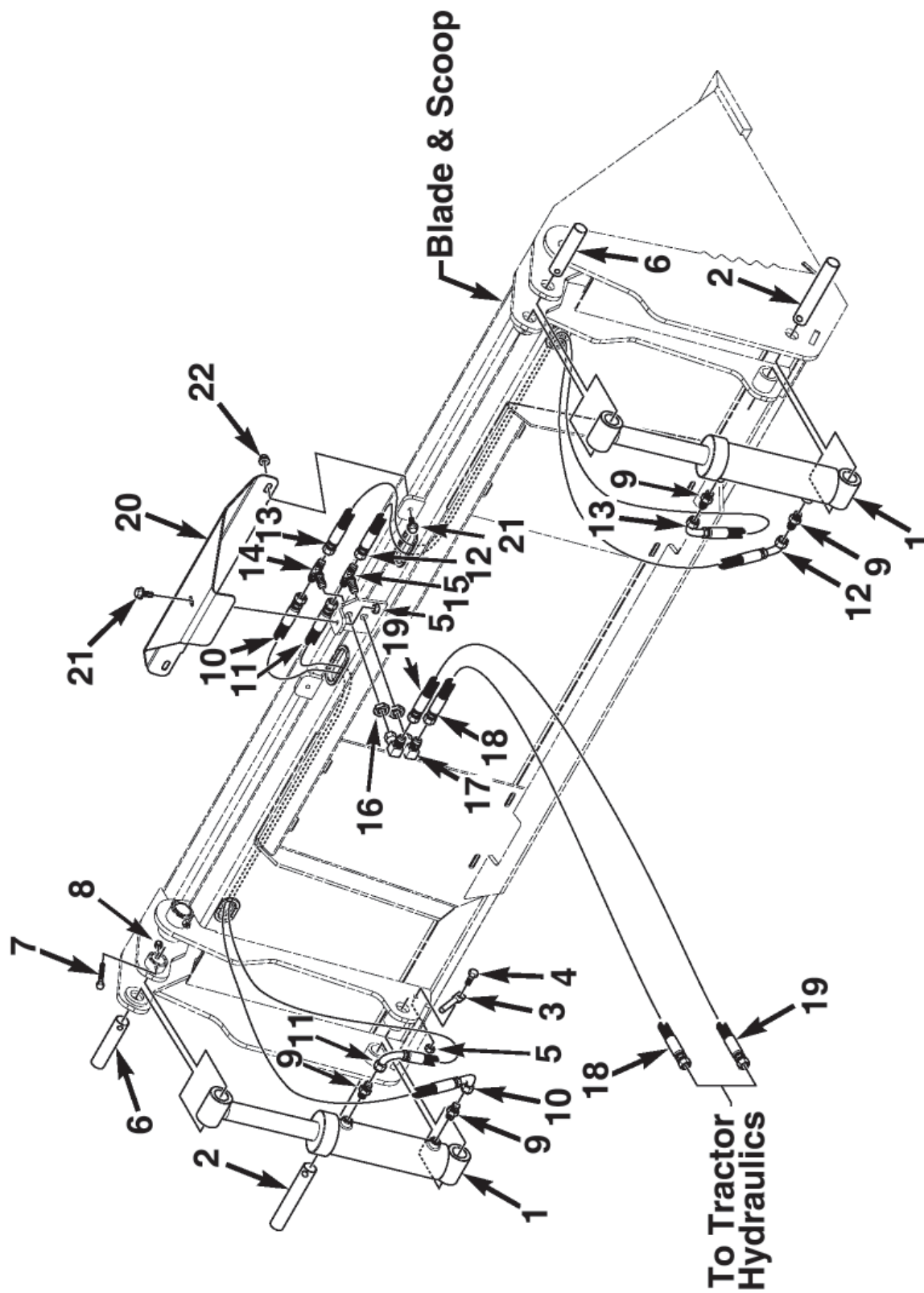

7.4 CYLINDER ASSEMBLY, 2" BORE x 6" STROKE

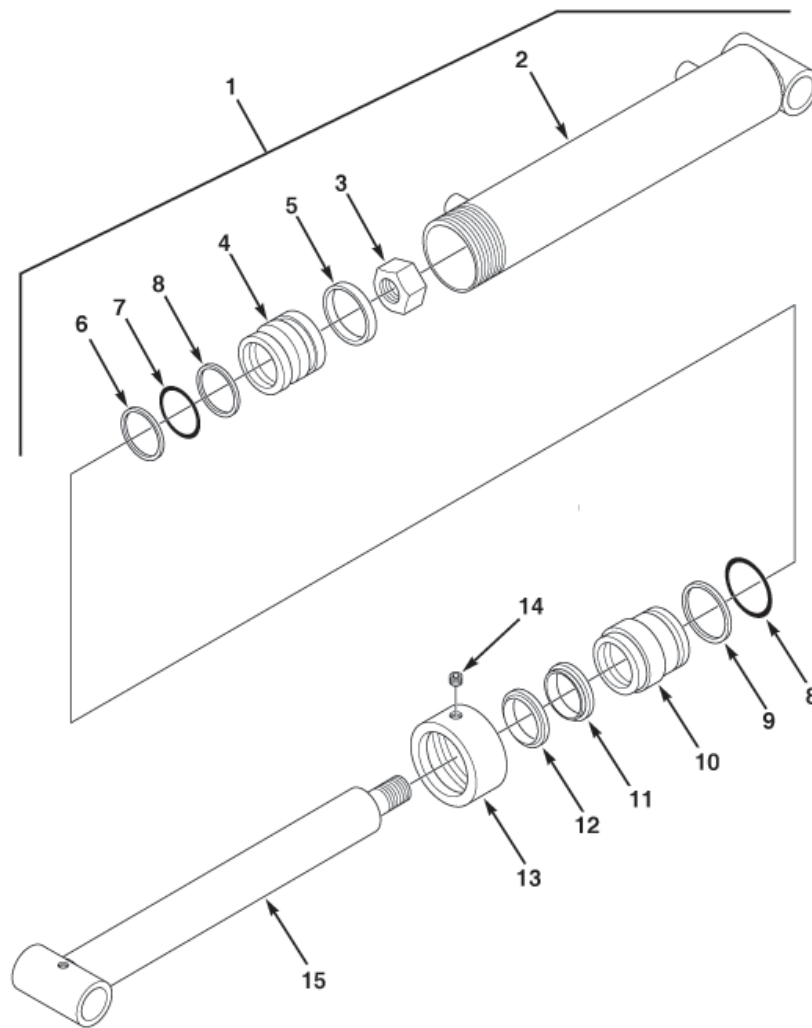

<u>REF #</u>	<u>QTY.</u>	<u>PART NO.</u>	<u>DESCRIPTION</u>
1	1	000-166-356	Cylinder Assy, 2" Bore x 6" Stroke, Includes 2 thru 15
2	1	000-166-357	Barrel Assembly
3	1	O/L	Nut, Lock, 1/2" - 20UNF
4	1	000-166-313	Piston
5	1	NSS	Uniring
6	1	NSS	Ring, Back Up
7	1	NSS	O-Ring
8	1	NSS	O-Ring
9	1	NSS	Ring Back Up
10	1	000-166-314	Head, Cap, Threaded
11	1	NSS	U-Cup, Loaded
12	1	NSS	Wiper, Rod
13	1	000-166-315	Cap, Threaded
14	1	O/L	Screw, Set, 1/4" - 20UNC x 1/4" Long
15	1	000-166-316	Rod Assembly
	As Req'd	000-166-317	Cylinder Repair Kit (Includes Items 5 thru 9, 11 & 12)

7.6 PARTS ACRONYMS

NSS	-	Not Serviced Separately
ASN	-	After Serial No.
BSN	-	Before Serial No.
O/L	-	Obtain Locally
BH	-	Bulkhead
MP	-	Male Pipe
FP	-	Female Pipe
FPX	-	Female Pipe Swivel
MB	-	Male O-Ring Boss
FB	-	Female O-Ring Boss
MJ	-	Male JIC
FJ	-	Female JIC
FJX	-	Female JIC Swivel

8 LIMITED WARRANTY



GEARMORE, INC., warrants each new Gearmore product to be free from defects in material and workmanship for a period of twelve (12) months from date of purchase to the original purchaser. This warranty shall not apply to implements or parts that have been subject to misuse, negligence, accident, or that have been altered in any way.

Our obligation shall be limited to repairing or replacement of any part, provided that such part is returned within thirty (30) days from date of failure to Gearmore through the dealer from whom the purchase was made, transportation charges prepaid.

This warranty shall not be interpreted to render us liable for injury or damages of any kind or nature, direct, consequential or contingent, to person or property. This warranty does not extend to loss of crops, loss because of delay in harvesting or any other expenses, for any other reasons.

Gearmore in no way warrants engines, tires, or other trade accessories, since these items are warranted separately by these respective manufacturers.

Gearmore reserves the right to make improvements in design or changes in specification at any time, without incurring any obligations to owners or units previously sold.

GEARMORE, INC.
13477 Benson Ave.
Chino, CA 91710

Always refer to and heed machine operating warning decals on machine.

The serial number of this product is stored in our computer database, thus submitting a warranty registration card is not required.