



VENTURI AIR SPRAYERS 3-PT. HITCH MODELS

**Assembly, Operation &
General Information
Manual**

s/n 090500 -----

May 2010

TABLE OF CONTENTS

Introduction	1
How To Operate The sprayer	2
Operation Of Ball Valve	3-4
Important Information	5
Mounting To The 3-Point Hitch	6
General Maintenance/Cleaning & Storage	7
Safety Decals	8-10
Important Notices	11
General Safety Information	12
Lubrication & Maintenance	13
Fan Support Oil Level Check	14
Main Strainer Maintenance	15
Belt Tension	16
Mounting Of Spray Heads	17
Modular System	18
Limited Warranty:	19

Date of Purchase:_____

Model Number:_____

Serial Number:_____

INTRODUCTION

We welcome you as an owner of the Gearmore Venturi Air Sprayer. This sprayer has the latest technical features and benefits that today's market demands. Yet, the sprayer is quite simple to use and maintain. Before you read on to the operation and maintenance of the sprayer, please read the following general information.

POWER SOURCE: The sprayer is designed to mount to any 540 RPM tractor with a 3-point hitch.

PUMP: The pump on the sprayer is a low pressure centrifugal type. There is one very important point to remember with centrifugal pumps; the pump uses the liquid to cool itself. Thus, if you run the pump dry, it will be damaged quickly.

TANK: The tank is thick walled polyethylene, which is corrosion resistant to most chemicals.

BLOWER: Air is supplied by a centrifugal fan. The fan is made of steel and is precision balanced for smooth operation. The fan housing is made of high strength polyethylene. A special overrunning clutch is mounted on the blower assembly to prevent damage.

AGITATION: This sprayer features a unique dual agitation system, a liquid system that uses by-pass liquid from the pump and an air system that uses air from the fan and introduces it to the bottom of the tank.

ASSEMBLY

The sprayer comes almost completely assembled, so only a few steps are required:

1. The air agitation control valve is shipped loose to prevent damage. Mount this valve and air hose assembly in the top of the tank by installing the lock nut on the inside of the tank. After installing the air valve, connect the air agitation hose that is inside the tank to the nipple on the bottom of the air valve.
2. Mount the distribution head onto the sprayer using the clamps that are provided. Connect the hoses and Dial-A-Rate metering system to the distribution head distributors.
3. Mount fan screen to housing.
4. Install the rear bumper and adjust the height so that it does not obstruct the operation of the distribution head.

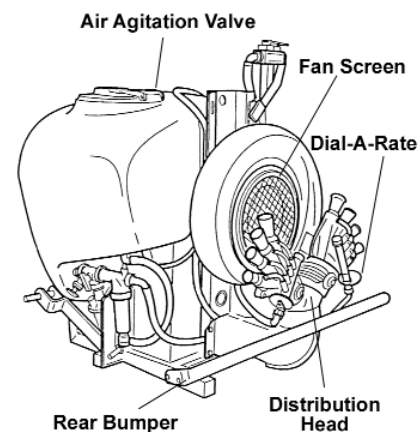

HOW TO OPERATE THE SPRAYER

1. Connect the sprayer to the tractor 3-point hitch.
2. Connect the PTO driveshaft after you have checked to make sure the driveshaft is not too long. Be sure to attach the PTO safety shield chains to the bottom crossbar on the sprayer and to the lower 3-point link arm on the tractor. After attaching, check the PTO shaft for correct length. There should be at least 1" - 2" clearance on the shaft when the sprayer is completely raised and lowered. Make sure there is less than a 15° angle on PTO shaft (see page 6).
3. Check the main filter strainer to make sure it is clean. Before cleaning the main filter, make sure the main ball valve (Ref. #1, page 3) is in the right position. When reassembling the filter strainer, make sure the large o-ring is seated properly.
4. Refer to the calibration chart to set the correct rate for your application. Then set the "Dial-A-Rate" to correspond to the gallons per acre you require. On your Gearmore Venturi Air Sprayer, you will have a pressure control valve, which regulates the amount of pressure from 15 to 40 PSI. Remember when setting your pressure, the higher the pressure setting, the less liquid agitation your tank will have. Also take into consideration that high pressure is not necessary when using the Gearmore Venturi Heads.
5. Open the air agitation valve on the top of the tank to introduce air for added agitation.

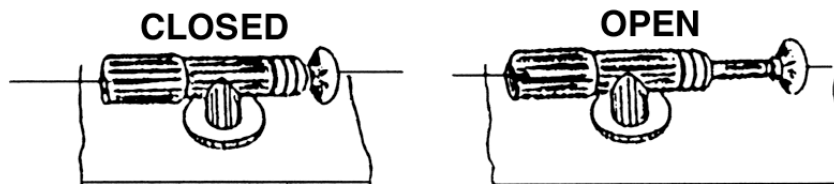

6. Engage tractor PTO at idle speed and run for a couple of minutes to make sure the chemicals are mixed thoroughly. Engage transmission and bring engine speed up to PTO speed of at least 540 RPM when spraying.
7. Turn on the remote liquid control valve or electro-valve switches, depending on how your sprayer is equipped. These valves can control right, left or both sides spraying, depending on what style of spray head you have mounted.

Remember, it is always best to make a practice run with just water to be sure you have correct rates and coverage.

OPERATION OF BALL VALVES

s/n 090000 -----

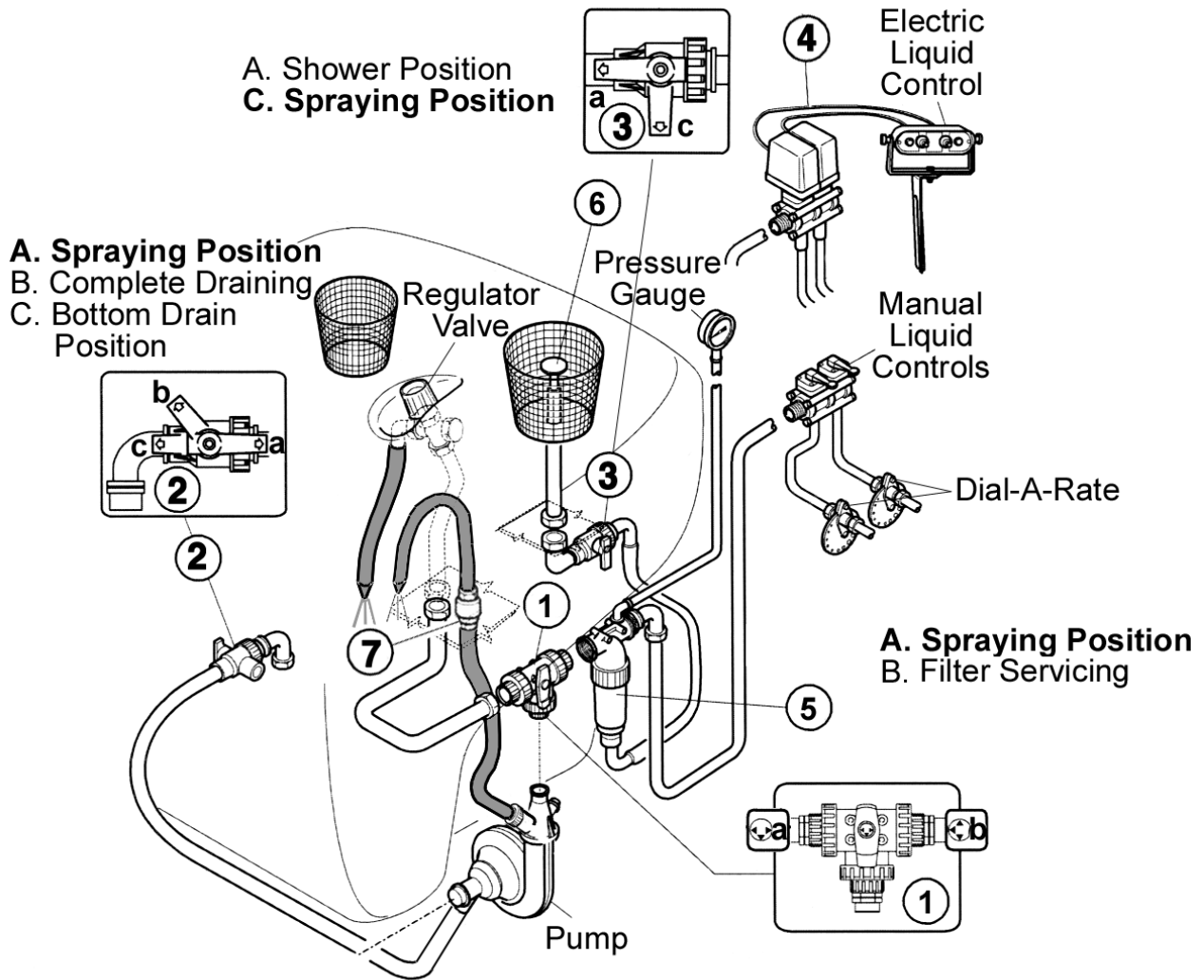

Legend:

- 4 - Electric Liquid Motors (Optional)**
- 5 - Filter Assembly**
- 6 - Shower Head**
- 7 - Check Valve**

OPERATION OF BALL VALVES

1. **Three Way Ball Valve** - Mounted at top of pump

Position A - Spraying

The handle must be placed down toward the pump. (**Gearmore recommends leaving in Position A at all times**)

Position B - Filter Servicing

The handle must be placed towards front of sprayer. This shuts off liquid flow path to the filter assembly (**Ref. #5**), allowing filter to be serviced.

Cannot operate spray heads in this position.

2. **Three Way Valve** - Mounted on bottom of tank opposite pump side

Position A - Spraying Position

This position allows liquid to flow to pump.

Position B - Complete Draining

This position allows you to bottom drain the tank and any liquid remaining in the pump and lines.

Position C - Draining Tank

**** Due to the quality of ditch water, Gearmore does not recommend bottom filling.***

3. **Two Way Valve** - Mounted to bottom of tank behind filter assembly (ref. 5)

Position A - Shower Head Open

In this position, liquid is sent to shower head.

NOTE: Never spray with this valve open

Position C - Spraying

The handle must point sideways at all times when not using shower heads.

IMPORTANT INFORMATION

Most Venturi heads have a liquid distributor on them (picture 1). All the tap assemblies (ref. B) have manual shut-offs. If these shut-offs are turned, it will cut off liquid flow to the hose coming off that tap. Generally the factory leaves these taps all in the open position.

In certain applications, such as with a T4+4 or T5+5 head (picture 2), you might not need all the nozzles putting out liquid. In this application what you should do is turn the shut-off to the horizontal position to cut liquid off to the corresponding nozzles and then replace the Venturi nozzle with a cap (part #02.127.000).

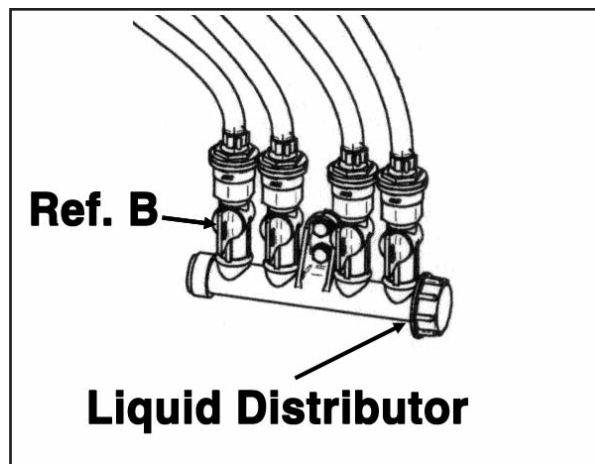

Picture 1

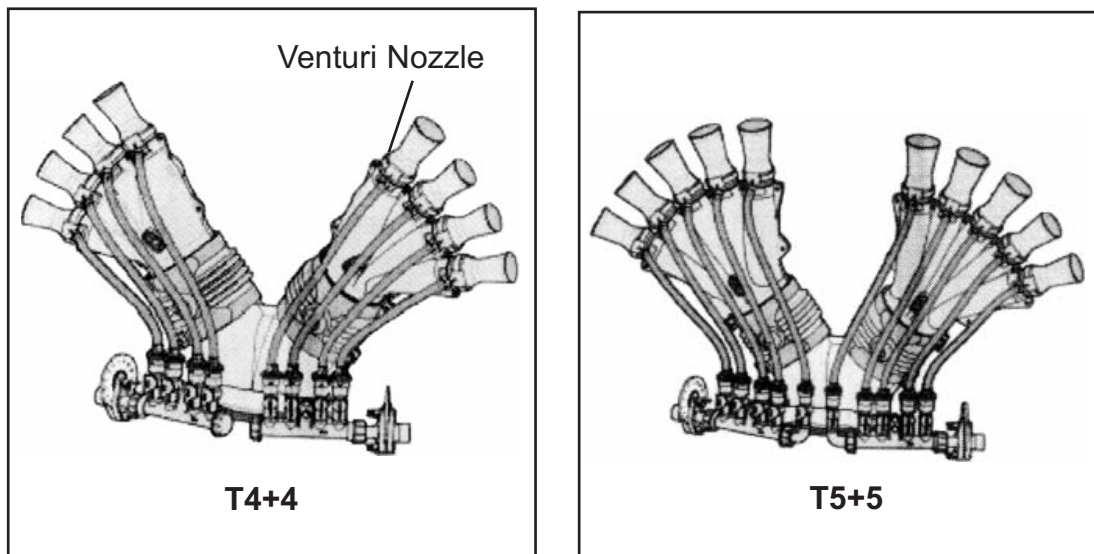

Picture 2

MOUNTING TO THE 3-POINT HITCH

It is absolutely essential that the connection be made so that when in use, the 2 power take-off points are running in line as close as possible (fig. 1). If not, the axes must be PARALLEL from side to side (fig. 2) and the misalignment must be limited to prevent the universal joint working at an angle of more than 15° (fig. 3).

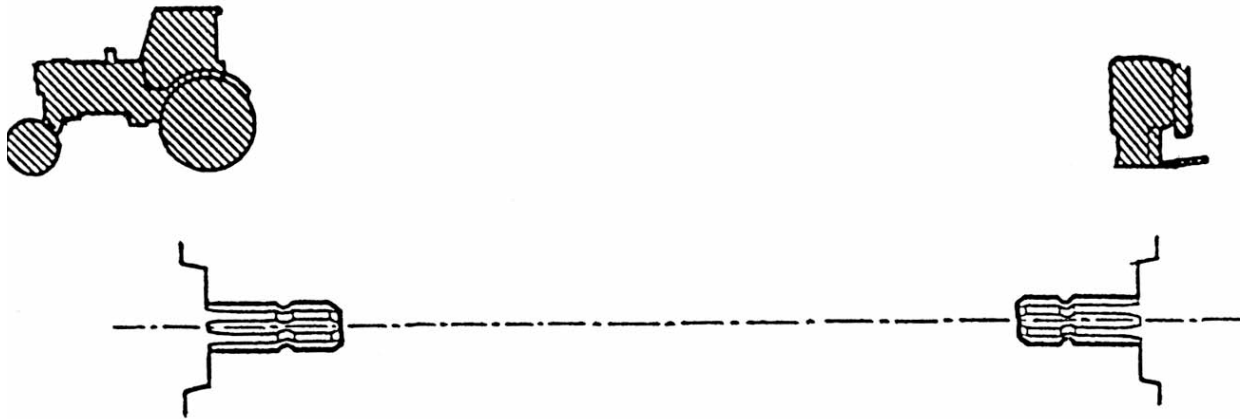

Fig. 1



Fig. 2

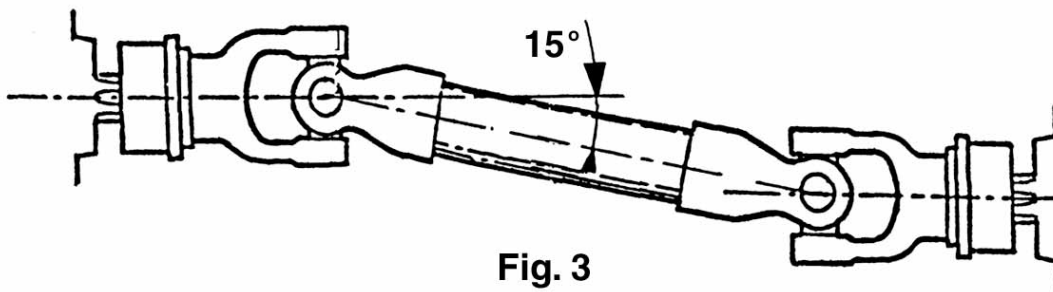

Fig. 3

GENERAL MAINTENANCE

Carefully follow all instructions as stated in this operator's manual, this includes lubrication, maintenance and operation of the sprayer. The sprayer was designed and built for years of reliable service if properly cared for. However, this sprayer is a high RPM machine, thus attention is required.

- ✓ Check all bolts for tightness
- ✓ Check sprayer for leaks
- ✓ Check main fan power belt
- ✓ Check pump drive belt
- ✓ Check to make sure no foreign objects are in or near the power system

CLEANING AND STORAGE

1. Wash and flush out sprayer after completion of each phase of your spraying program.
2. Flush out sprayer when changing chemicals if there is a possibility of incompatibility.
3. Clean sprayer very thoroughly before storing at the end of the spraying season. If you are in a cold climate, final rinse should be with a sufficiently concentrated anti-freeze to prevent freeze-up in areas that were not thoroughly drained.
4. Check sprayer over for needed repairs before time to spray again.
5. Preparing the sprayer for use in the Spring means completion of all needed repairs, installation of all drain plugs and checking sprayer for leaks with a tank of water.

SAFETY TIPS

- ☛ Sprayer should be operated only by qualified persons.
- ☛ Always fill sprayer slowly to avoid spillage.
- ☛ When starting sprayer, maintain a safe distance from all moving parts.
- ☛ Never run PTO at speeds in excess of 540 RPM.
- ☛ Do not make adjustments when sprayer is running, unless specifically recommended.
- ☛ Never leave sprayer unattended while it is running.
- ☛ Keep hands, feet and clothing away from all moving parts.
- ☛ Handle chemicals carefully; follow the manufacturer's directions for mixing and applying chemicals.

SAFETY DECALS

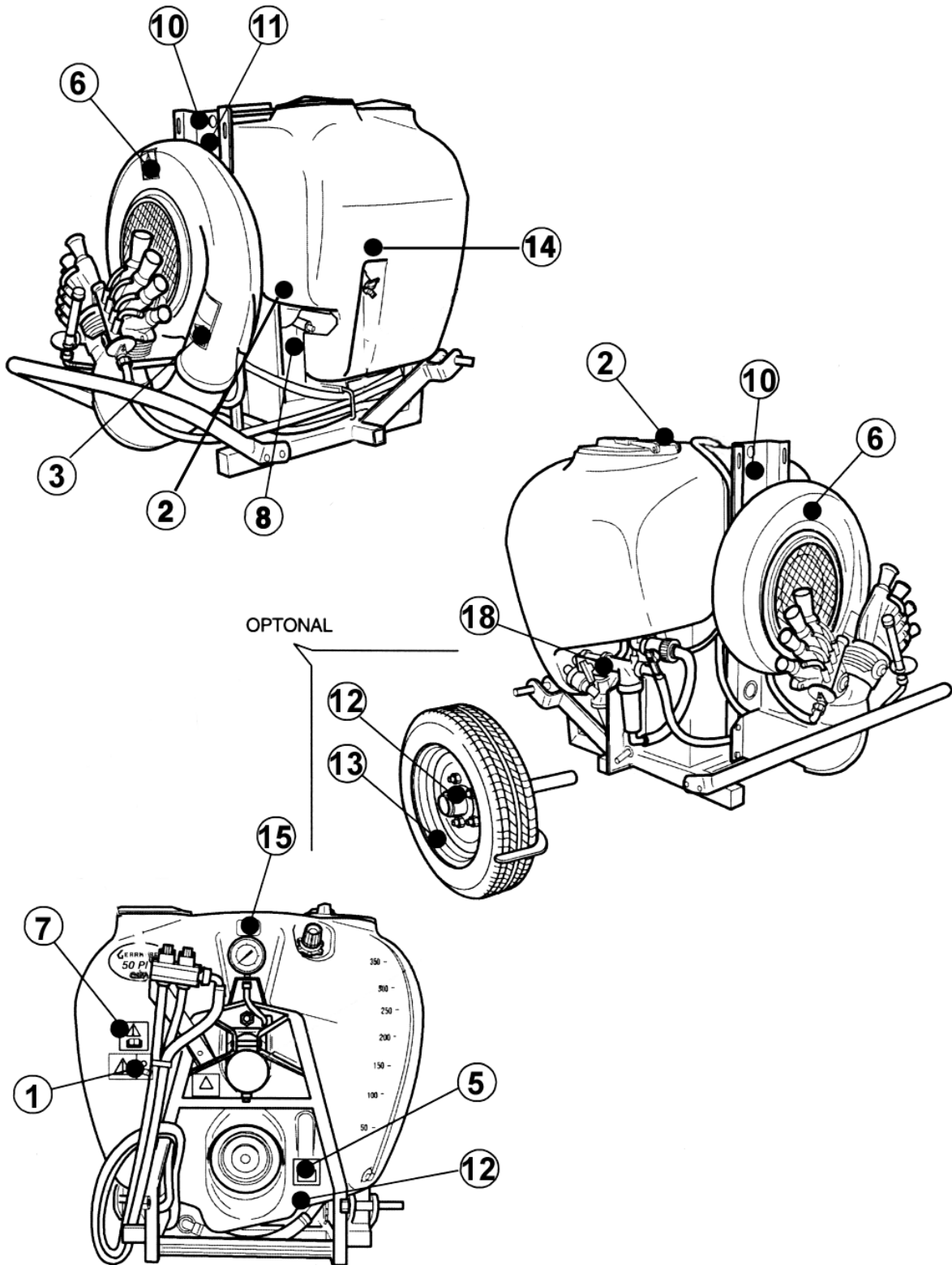

SAFETY DECALS

SAFETY DECALS

1. **95001 - STOP THE ENGINE AND REMOVE THE KEY FROM THE TRACTOR'S CONTROL PANEL BEFORE CARRYING OUT ALL MAINTENANCE OR REPAIR OPERATIONS**

- Positioned on the left-hand side of the tank in the forward part of the machine.

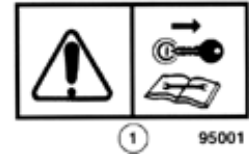

2. **95004 - DANGER OF CONTAMINATION BY CONTACT OR POISONOUS PRODUCTS INHALATION**

- Positioned above the tank, in the forward part, next to the filler spout.



3. **95005 - DANGER, PARTS IN MOTION. BEFORE REMOVING PROTECTION GUARDS, STOP THE TRACTOR, REMOVE THE KEY FROM THE TRACTOR'S CONTROL PANEL AND ENSURE THAT ALL MOVING PARTS HAVE STOPPED**

- Positioned on the fan casing next to the outflow vent.

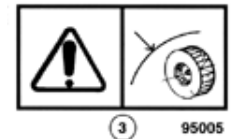

5. **95010 - MAXIMUM OPERATING SPEED OF THE DRIVE OUTLET (PTO): 540 RPM**

- Positioned on the forward part of the machine, on the lower part of the tank and close to the drive outlet.



6. **95007 - DANGER OF SPRAYS: KEEP AT A SAFE DISTANCE**

- Positioned on the upper part of the fan casing.



7. **95006 - WARNING: CONSULT THE USER AND MAINTENANCE MANUAL BEFORE USING OR INTERVENING ON THE MACHINE**

- Positioned on the left-hand side of the tank, in the forward part of the machine.



8. **95009 - DANGER: GLOVES MUST BE USED TO EMPTY THE TANK**

- Positioned on frame behind drain ball valve.



SAFETY DECALS

USE & MAINTENANCE DECALS

10. 95059 - HOOKING POINT FOR THE LIFTING OF THE MACHINE

- Positioned on the frame, above the fan's casing.



11. 95079 - CHECK THE OIL LEVEL EVERY 8 HOURS: FAN SHAFT BEARINGS (Not on P42N)

- Positioned on the chassis, over the fan casing.



12. 95054 - GREASE EVERY 200 HOURS: FAN TIGHTENER SUPPORT, FREEWHEEL AND WHEEL HUBS

- Positioned on the chassis, in the low, rear side, on the left.
- Positioned in the front section, on the tank, in a low position near the PTO.



- Positioned on the wheel (accessory).

13. 95060 - INDICATION OF THE WHEELS OPERATING PRESSURE

95056 - INDICATION OF THE WHEELS OPERATING PRESSURE

- Positioned on the wheel (accessory)

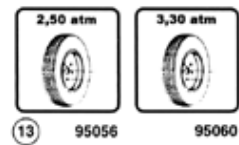

14. 95057 - HAND WASHING TANK TAP

- Positioned on the right hand side of the tank, next to the tap.



15. 95065 - WARNING: NEVER OPERATE THE SPRAYER WITHOUT LIQUID IN THE TANK

- Positioned on the forward part of the tank, above the gauge.



17. 95069 - INDICATIONS FOR THE USE AND MAINTENANCE OF THE SOLENOID VALVES (Optional)

- Positioned on the tank, on the side of the electrical distributor.

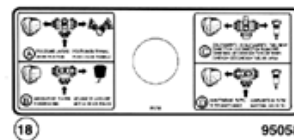

18. 95058 - INDICATION ON THE OPERATION OF THE 3-WAY TAP

- Positioned on the left hand side of the tank, above the pump.



IMPORTANT NOTICE

To obtain effective spray atomization and chemical agitation, you must operate your tractor at recommended maximum engine RPM to obtain correct PTO speed of 540 RPM.

DO NOT ALLOW POWDER CHEMICALS TO STAY IN THE TANK WITHOUT AGITATION

Powder chemicals that do not dissolve will settle to the bottom of the tank when the agitation is stopped and may damage the pump when it is restarted.

NEVER USE A STICKER PRODUCT WITH TEFLON, BOND OR TACTIC INGREDIENTS

If a sticker is needed, Gearmore recommends Latron B1956 or compatible products.

AFTER EACH USE BEFORE STORING THE SPRAYER

1. Be sure to drain and clean out the tank.
2. Run clean water through the entire system.
3. Remove the cap on the front of the pump.
4. Remove and clean the main filter.

GENERAL SAFETY INFORMATION

DO NOT OPERATE PUMP WITHOUT LIQUID IN TANK



WARNING:



Do not pump flammable or explosive fluids such as gasoline, fuel oil, kerosene, etc. Do not use in explosive atmospheres. The pump should be used only with liquids compatible with the pump component materials. Failure to follow this warning may result in personal injury and/or property damage and will void the product warranty.

- ⇒ Do not operate pump above recommended RPM.
- ⇒ Operate pump between 45° F and 145° F liquid temperatures.
- ⇒ Make certain that the power source conforms to the requirements of your equipment.
- ⇒ Provide adequate protection in guarding around the moving parts such as the shaft and pulleys.
- ⇒ Disconnect power before servicing.
- ⇒ Release all pressure within the system before servicing any component.
- ⇒ Drain all liquids from the system before servicing.
- ⇒ Secure the discharge lines before starting the pump. An unsecured discharge line may whip, causing personal injury and/or property damage.
- ⇒ Check hoses for weak or worn conditions before each use. Make certain that all connections are tight and secure.
- ⇒ Periodically inspect the pump and the system components. Perform routine maintenance as required (see Maintenance section).
- ⇒ Do not use these pumps for pumping water or other liquids for human or animal consumption.

LUBRICATION & MAINTENANCE

1. The oil fill for the fan support bearings is located behind the fan housing and in front of the main frame by the fan housing. Check the oil *every 8 hours* of use. The oil needs to be changed *yearly*. (Note: Models P45N1, P50N1, P50S1 and P55S1)
2. The grease zerk for the fan bearing assembly is located on the left side of the fan housing. Grease this zerk *every 20 hours* of use. (Note: Model P42N1 only)
3. The main drive belt idler assembly has sealed bearings, but the idler needs to be greased *every 200 hours* to allow it to pivot freely. This grease zerk is located on the right main frame by the fan housing.
4. The overrunning clutch is designed to allow the fan assembly to rotate freely when the tractor PTO is shut down. This grease zerk is located behind the PTO driveline and requires you to remove the PTO to lubricate. Grease this zerk *every 200 hours* of use.
5. The PTO driveshaft u-joints should be greased *every 8 hours* and the shafts *every 20 hours*. The PTO safety shields have a plastic zerk for the shield bearings that should also be greased *every 20 hours*.

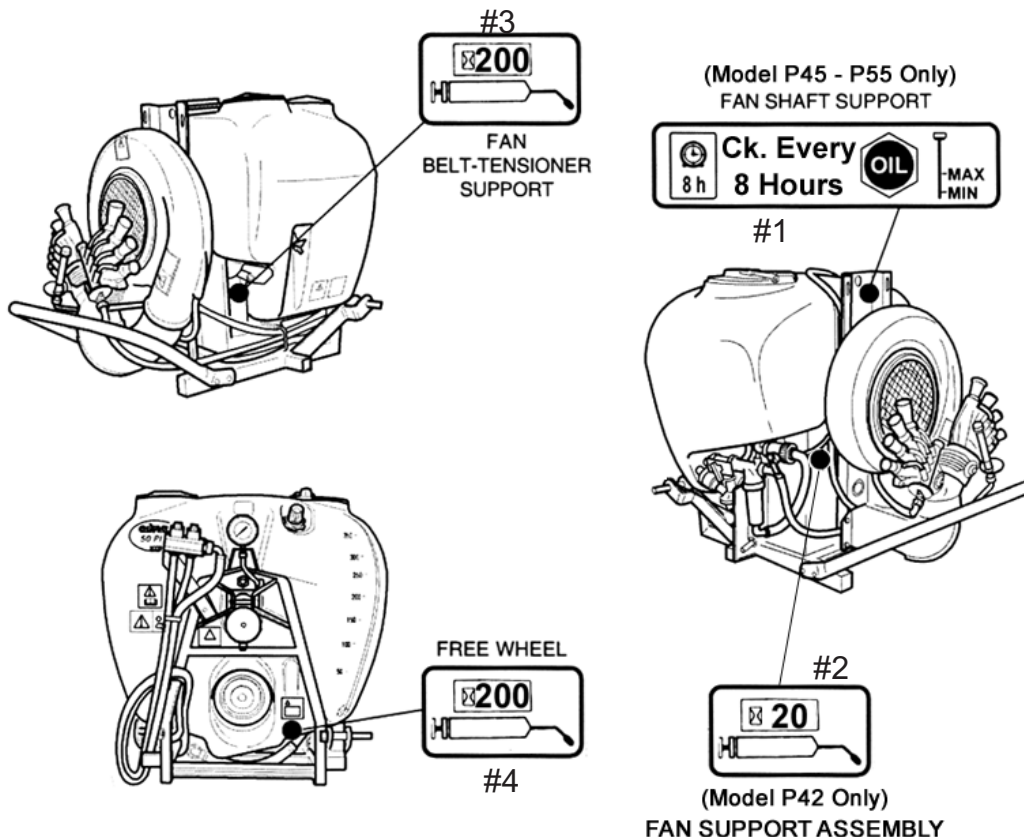

FAN SUPPORT OIL LEVEL CHECK

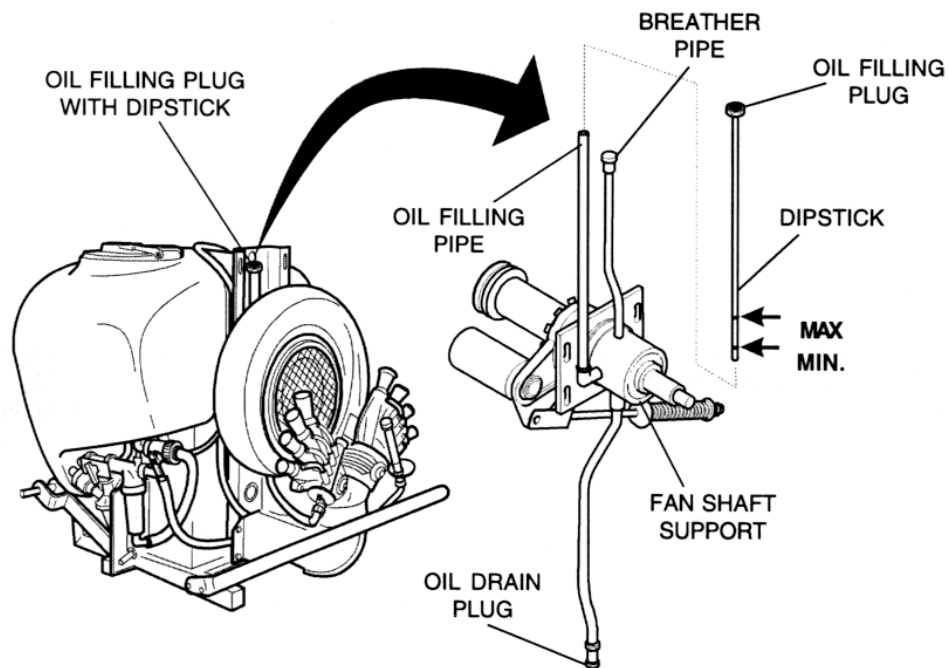

1. Unscrew and remove the oil filling plug with dipstick.
2. Clean the dipstick and reinsert in oil tube.
3. Remove dipstick and check oil level. Oil should be between the min. and max. marking on dipstick. If oil is low add SAE 90 wt. oil.
4. Reinstall dipstick and re-tighten.

CHANGING FAN SUPPORT OIL

1. Unscrew and remove the oil filling plug with dipstick.
2. Remove the oil drain plug and drain oil completely.
3. Replace oil drain plug.
4. Through the filling pipe, pour SAE 90 wt. oil to proper level on dipstick.
5. Reinstall dipstick and re-tighten.

MAIN STRAINER MAINTENANCE

MAIN STRAINER:

Clean strainer screen before each treatment and when required.

To clean screen, it is necessary to make sure the ball valve (Ref. 1) is in Position B. Return to Position A when finished.

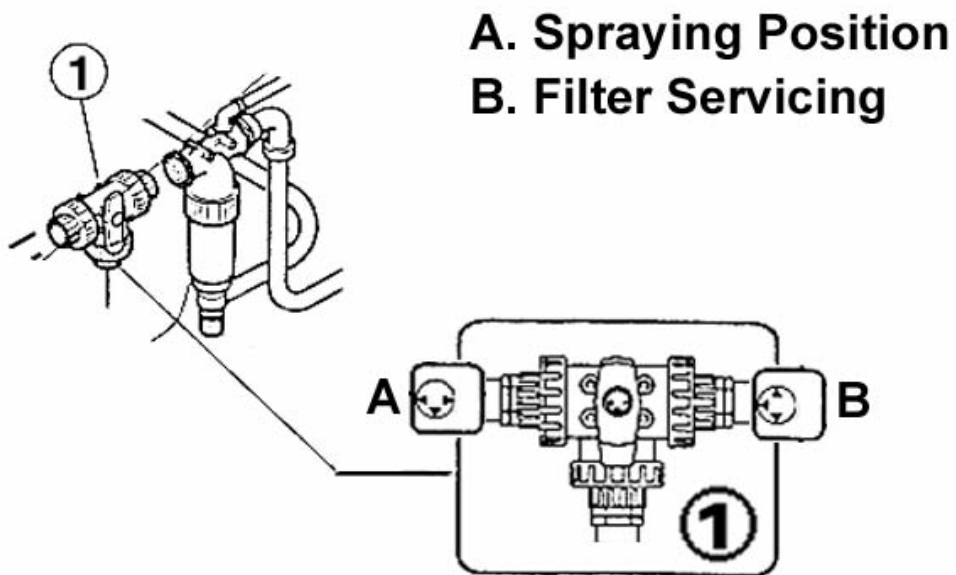

BELT TENSION

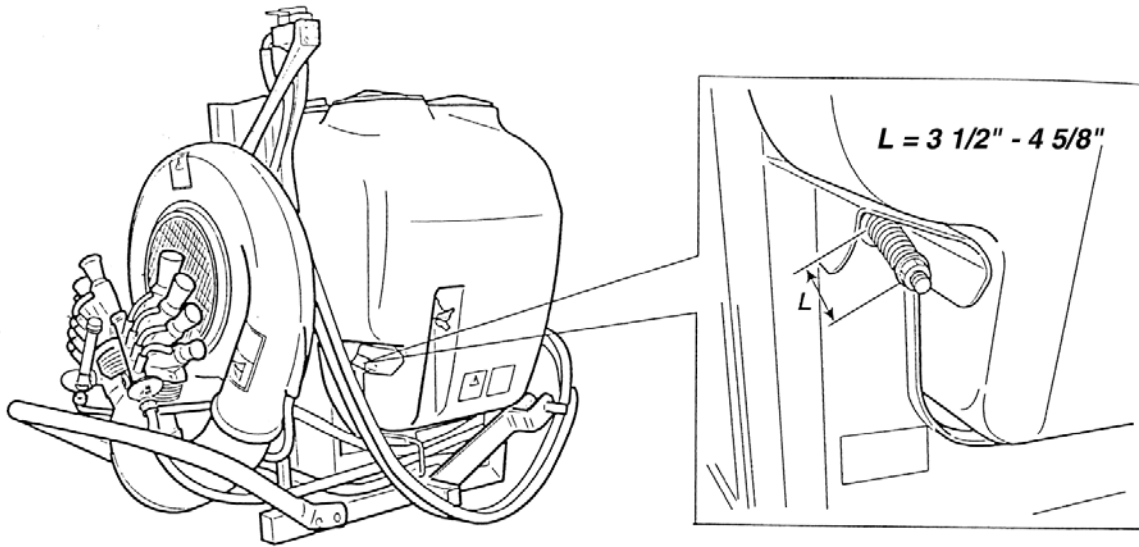

MAIN POWER DRIVE BELT:

Minimum Length = 3 1/2"
Maximum Length = 4 5/8"

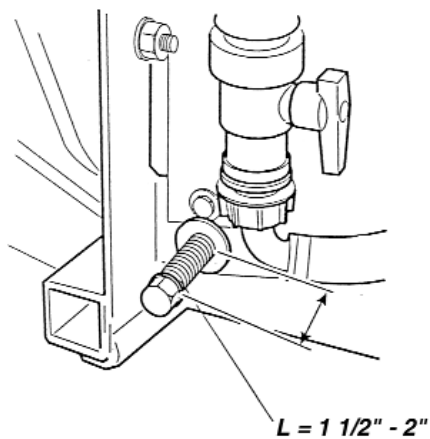

CENTRIFUGAL PUMP V-BELT:

Minimum Length = 1 1/2"
Maximum Length = 2"

MOUNTING OF THE SPRAY HEADS

The Gearmore Venturi Air sprayer can be used in a number of different applications depending on the crop. For each type of crop, we have different styles of spray heads available to match particular applications. We can mount the spray heads either high or low to achieve total plant coverage. Follow the simple instructions for mounting the spray heads below.

To place the fan housing in position as illustrated in (A) or (B), do the following:

1. Loosen the locking bolts (C) on both sides of the fan housing clamp with a 17mm socket and extension.
2. Rotate the fan housing in the (A) or (B) position in relation to the type of distribution equipment you have to mount.
3. Install your spray head to the elbow mounted on the fan housing and check to be sure that the unit is positioned properly - is of equal heights from the ground and the unit is able to mount to the back side of the main frame for added support. If you don't have the spray heads mounted properly, it could cause the unit to not perform to its full potential. Be sure to check that everything fits together properly. Install spacers if needed so that there is no excess strain on the fan housing. When using the 4+4 or 5+5 vineyard heads, you should angle the venturi nozzles back similar to an inverted "V" ("∧" refer to picture).
4. With the socket wrench, tighten the fan housing into the right position by tightening the (C) bolts.

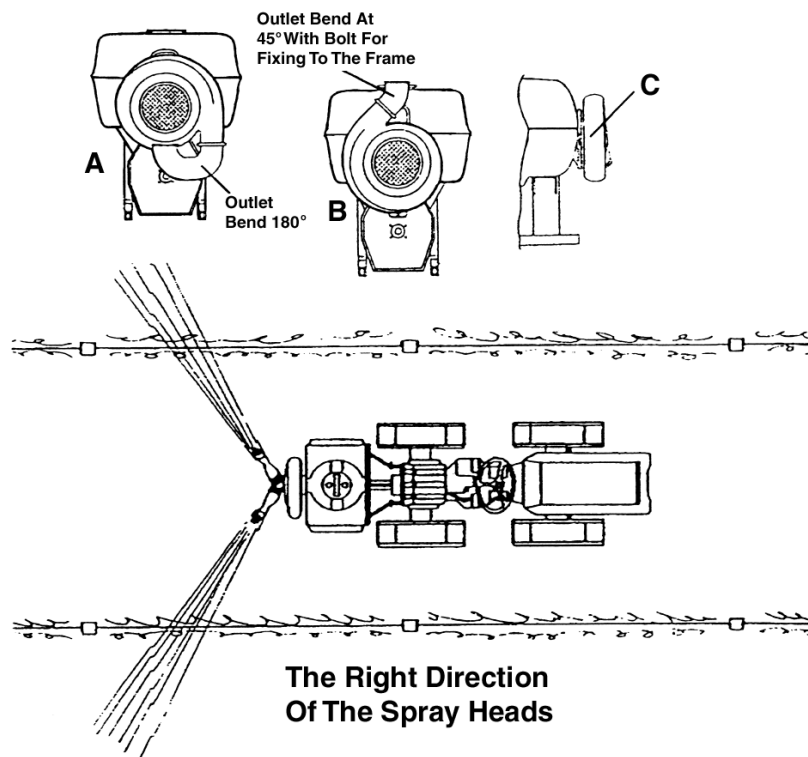

MODULAR SYSTEM

SWITCH BOX PART #02.391.07C



CABLE CONNECTION

Connect the red cable to a 12V positive supply, with a minimum capacity of 8 amps, possible from the ignition switch. connect the black cable to ground, making sure of a clean connection point and that this point connects with battery minus (-).

Always use screw connections and proper terminal ends for wiring, making sure to insulate any bare connections. Protect connections with junction boxes and cable holders. Ensure wiring will not be trapped or rubbed with vibration. Check fuse rating and location.

LIMITED WARRANTY



GEARMORE, INC., warrants each new Gearmore product to be free from defects in material and workmanship for a period of twelve (12) months from date of purchase to the original purchaser. This warranty shall not apply to implements or parts that have been subject to misuse, negligence, accident, or that have been altered in any way.

Our obligation shall be limited to repairing or replacement of any part, provided that such part is returned within thirty (30) days from date of failure to Gearmore through the dealer from whom the purchase was made, transportation charges prepaid.

This warranty shall not be interpreted to render us liable for injury or damages of any kind or nature, direct, consequential or contingent, to person or property. This warranty does not extend to loss of crops, loss because of delay in harvesting or any other expenses, for any other reasons.

Gearmore in no way warrants engines, tires, or other trade accessories, since these items are warranted separately by these respective manufacturers.

Gearmore reserves the right to make improvements in design or changes in specification at any time, without incurring any obligations to owners or units previously sold.

GEARMORE, INC.
13477 Benson Ave.
Chino, CA 91710

Always refer to and heed machine operating warning decals on machine.